

Live Production System LPS-1

USER MANUAL

July 2026 • 1.4.1 • English

D4510006703 • K11754



Disclaimer

Before using the product, be sure to read and understand all respective instructions.

The product is available for commercial customers only.

For product specification changes since this document was published, refer to the latest publications of ARRI data sheets or data books, etc., for the most up-to-date specifications.

Not all products and / or types are available in every country. Please check with an ARRI sales representative for availability and additional information.

The information given in this document is subject to change without notice.

While ARRI endeavors to enhance the quality, reliability and safety of their products, customers agree and acknowledge that the possibility of defects thereof cannot be eliminated entirely. To minimize risk of damage to property or injury (including death) to persons arising from defects in the products, customers must incorporate adequate safety measures in their work with the system and have to heed the stated canonic use.

ARRI or its subsidiaries expressly exclude any liability, warranty, demand or other obligation for any claim, representation, or cause, or action, or whatsoever, express or implied, whether in contract or tort, including negligence, or incorporated in terms and conditions, whether by statute, law or otherwise. In no event shall ARRI or its subsidiaries be liable for or have a remedy for recovery of any special, direct, indirect, incidental, or consequential damages, including, but not limited to lost profits, lost savings, lost revenues or economic loss of any kind or for any claim by third party, downtime, good will, damage to or replacement of equipment or property, any cost or recovering of any material or goods associated with the assembly or use of our products, or any other damages or injury of the persons and so on or under any other legal theory.

Neither ARRI nor its subsidiaries assume any liability for infringement of patents, copyrights or other intellectual property rights of third parties by or arising from the use of ARRI products or any other liability arising from the use of such products. No license, express, implied or otherwise, is granted under any patents, copyrights or other intellectual property right of ARRI or others.

In the case one or all of the foregoing clauses are not allowed by applicable law, the fullest extent permissible clauses by applicable law are validated.

Document Revision History

Document Revision History

Document ID: D45 1000 6703

Version	Release	Date	Note
1.0	K10948	July 2024	First Release
1.1	K11240	May 2025	Release for SUP 1.1
1.2	K11289	July 2025	Release for SUP 1.2
1.2.1	K11380	December 2025	Release for SUP 1.2.1
1.3.0	K11754	March 2026	Release for SUP 1.3.0
1.4.1	K11784	July 2026	Release for SUP 1.4.1

Imprint

© 2024 - 2026 Arnold & Richter Cine Technik GmbH & Co. Betriebs KG. All rights reserved.

The product contains proprietary information of Arnold & Richter Cine Technik GmbH & Co. Betriebs KG; it is provided under a license agreement containing restrictions on use and disclosure and protected by copyright law. Reverse engineering of the software is prohibited.

No part of this publication shall be used for distribution, reproduction, transmission, transcription, storage in a data retrieval system, or translated into any language in any form by any means without the prior written permission of Arnold & Richter Cine Technik GmbH & Co. Betriebs KG.

If you are downloading files from our web pages for your personal use, make sure to check for updated versions.

ARRI cannot take any liability whatsoever for downloaded files, as technical data are subject to change without notice.

Due to continued product development the information in this document may change without notice. The information and intellectual property contained herein is confidential between ARRI and the client and remains the exclusive property of ARRI. If you find any problems in the documentation, please report them to us in writing. ARRI does not warrant that this document is flawless.

ARRI, ALEXA 35 and ARRIRAW are trademarks or registered trademarks of Arnold & Richter Cine Technik GmbH & Co. Betriebs KG. All other brands or products mentioned are trademarks or registered trademarks of their respective holders and should be treated as such.



Apple ProRes 422 HQ, Apple ProRes 4444, Apple ProRes 4444 XQ, and the ProRes logo are trademarks or registered trademarks of Apple Computer, Inc., used under license therefrom.

Original version.

Initial Language

The initial language of this user manual is English. User manuals in other languages are translations from English.

In the event of conflict between the respective languages (i.e. if any translation(s) of present document has/have been prepared for convenience or any other purpose), with regards to the meaning or interpretation of a word or an instruction etc., the contents and provisions of the English language version shall prevail.

For Further Assistance

Arnold & Richter Cine Technik GmbH & Co. Betriebs KG

Herbert-Bayer-Str. 10

D-80807 Munich

Germany

E-mail: service@arri.de

Website: www.arri.com/en/technical-service

Table of Contents

1	About this Document	6
2	Fiber Base Station FBS-1	7
3	Fiber Camera Adapter FCA-1	14
4	Skaarhoj RCP Pro ARRI V2B	20
5	System Setup	21
5.1	Power Supply	21
5.2	Camera Configuration	22
5.4	Video	25
5.5	Audio	30
5.6	Genlock	32
5.7	Timecode	34
5.8	Intercom	35
5.9	GPI/O	36
5.10	Tally	39
5.12	Fiber Base Station Status Area	40
5.13	Fiber Camera Adapter Status Area	42
5.14	Diagnostics, Settings and Alerts	43
6	Remote Control	45
6.1	LPS-1 Web UI	45
6.2	SKAARHOJ Web Interface	45
6.3	Web Remote	45
7	Settings	47
7.1	Network Settings	47
7.2	Audio Settings	47
7.3	Video Settings	48
7.4	Genlock and Timecode Settings	48
7.5	Intercom Settings	49
8	Tally Light Module TLM-1	50
9	Large Lens Adapter LLA-1	51
9.1	Large Lens Adapter Control Module	51
10	Appendix	53
10.1	Technical Data	53
10.2	Pinouts	55
10.3	Update Procedures	60
10.4	LPS-1 Accessories	61

1 About this Document

This user manual contains detailed information about the features and functionalities of the device. Please visit the website www.arri.com to download the operating manual and much more information about this and other ARRI products.

The separate operating manual is aimed at everyone involved in using the device. It provides directions on how to operate it safely and as intended. To ensure safe and correct use, all users must read the operating manual before using the device for the first time.

Keep all manuals and all other operating and assembly instructions belonging to the device in a safe place for future reference and possible subsequent owners

1.1 Product Information Resources

The ARRI documentation portal provides important documents on the product for free download.

Please enter the following searchkeys in the search bar to retrieve the documents for the product:

LPS-1, FCA-1, FBS-1, TLM-1, LLA-1, K2.0050656,
K2.0051099, K0.0051070

[ARRI documentation portal](#)



For more details about the product, please refer to the ARRI website at:

[ALEXA 35 Live](#)



1.2 How to Use this Manual

All directions are given from a camera operator's point of view. For example, camera right side refers to the right side of the camera when standing behind the camera and operating it in a normal fashion.

Connectors are written in all capital letters, for example "AUDIO connector".

Buttons are written in italic typeface capital letters, for example "*PLAY* button".

Menu paths are written in italic typeface, with menu and home in capital letters, for example "*MENU > Recording > Sensor Mode*".

"EVF" refers to the OLED eyepiece of the MVF-2 viewfinder.

"Monitor" refers to the flip-out monitor of the MVF-2 viewfinder.

"VF" refers to the viewfinder connectors VF 1 and VF 2. When settings refer to VF, they affect the EVF and the flip-out monitor.

"Monitoring outputs" refers to EVF, flip-out monitor, SDI 1, and SDI 2.

"Status Info" refers collectively to the Status Info of EVF, SDI 1 and SDI 2.

2 Fiber Base Station FBS-1

The Fiber Base Station FBS-1 is a 19" 2U rack mount unit. As part of the ARRI ALEXA 35 Live Multicam System it connects to the Fiber Camera Adapter FCA-1 through a SMPTE311 or a tactical fiber cable.

The Fiber Base Station FBS-1 supplies power over a SMPTE311 hybrid fiber cable up to 2 km / 1.24 mi or up to 10 km using tactical fiber and powering the ARRI ALEXA 35 from the external power input.

Features of the Fiber Base Station FBS-1:

- Multiple HD / UHD outputs,
- four return video channels,
- hot interchangeable redundant power supplies,
- two channels of intercom,
- time code,
- program audio IN / OUT (AES / Line),
- Ethernet channel for camera control,
- independent Ethernet tunnel,
- tally (red / green / yellow),
- GPIO,
- Tracker, and
- Ethernet ports for access to the LPS-1 web UI.

2.1 FBS-1 Front Panel Overview

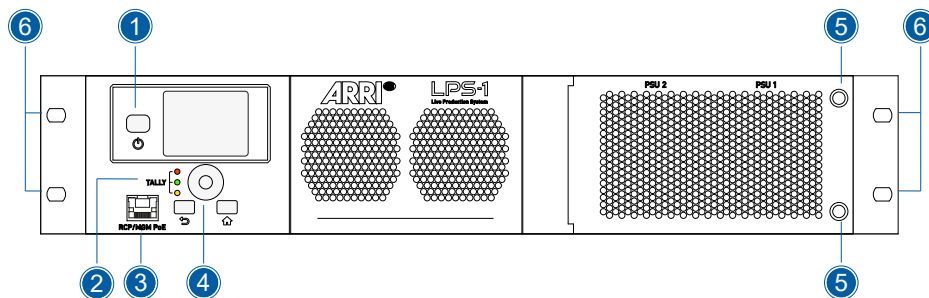

1	POWER button	3	RCP / MGM (PoE)	5	PSU Interlocks
2	TALLY Indication	4	Control Elements	6	Mounting holes

POWER Button

When the Fiber Base Station FBS-1 is connected to a power source and not energized, the *POWER* button (1) is illuminated with a red outer ring to show it is in standby mode. Push the *POWER* button to energize the unit. The illuminated outer ring turns white. To de-energize the unit, push and hold the *POWER* button.

Tally Indication

The tally indication (2) shows the production status of the unit (red, green, and yellow) when the tally signals are set by the external controller connected to the rear panel DB25 or through TSL.

RCP/MGM PoE

Use the RCP/MGM PoE RJ45 port (3) to connect a remote control panel directly to the Fiber Base Station FBS-1 or to access the integrated web interface with a computer.

Control Elements

Use the control elements (4) to navigate the menu, select and set menu items.

PSU 1 & PSU 2

The two power supply units (PSU 1 & PSU 2) are identical, interchangeable, hot-swappable and redundant. Open the front cover to swap them. If a failure occurs, the other power supply unit takes over. You can replace them when the system is energized. To access the power supply units, unscrew the two interlocks (5) and open the door.

Mounting Holes

Use the four mounting holes (6) to install the Fiber Base Station FBS-1 in a 19" rack.

2.2 FBS-1 Rear Panel Overview

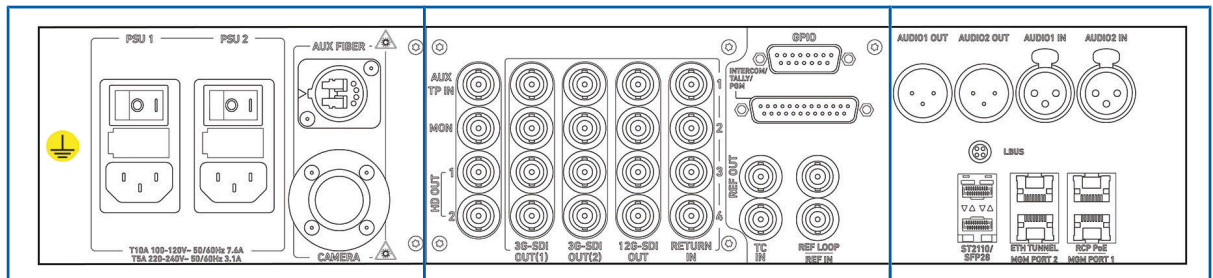

Section A

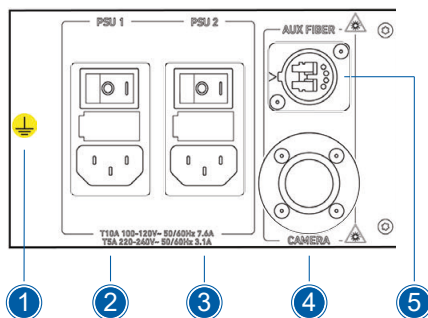

- 1 Earth Connector
- 2 PSU 1
- 3 PSU 2
- 4 CAMERA (Lemo 3K SMPTE 311M)
- 5 AUX FIBER (Neutrik Opticon)

Earth Connector

Always use the protective conductor connection (1) on the rear of the device to earth the device. Overvoltage (e.g. caused by a lightning strike) can enter the device through network connections.

PSU 1/2

Both power supply units (2, 3) accept an IEC 320 Universal AC mains power connector. The mains input voltage shall be within 100 – 240 V, 50 / 60 Hz.

In the event of a failure of one module, the other PSU module will automatically and seamlessly take over providing redundancy and preventing a shutdown. For this to function, both power cables need to be connected. The power supply units have a user-replaceable mains fuse in a fuse holder next to the mains power inlet connector. Please ensure that the correct fuse rating is fitted for your region to both units.

Please find detailed instructions how to replace the mains fuse in the LPS-1 operating manual. The operating manual is available for free download at the [ARRI documentation portal](#).

CAMERA (Lemo 3K SMPTE 311M Fiber Connector)

The Fiber Base Station FBS-1 can supply up to 400 W power for the camera and accessories over 2 km when connected with a SMPTE311 Fiber cable. The SMPTE311 Fiber cable has fibers and copper conductors for power supply and power monitoring functions.

When you energize the ARRI ALEXA 35 Live from an external power source, a tactical fiber cable can be used for operation over cable distances up to 10 km.



NOTICE

Always re-fit the protective cover for the SMPTE 311M connector to avoid contamination of the fiber connections from dust.

AUX FIBER (Neutrik Opticon)

You can connect an optical receiver / transmitter operating in the 1550 nm wavelength to the Auxiliary Fiber tunnel connector (5). It provides a second fiber path that is multiplexed on the SMPTE311 cable connected to the Fiber Camera Adapter FCA-1.

Example: Use a fiber optical converter to SDI to receive a video source transmitted through an SDI to fiber optical transmitter connected to the FCA-1 AUX Fiber connector.

Section B

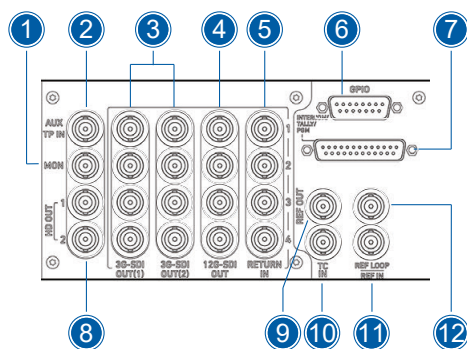

- 1 MON (BNC)
- 2 AUX TP IN (BNC)
- 3 3G-SDI OUT (1 / 2) 1 - 4
- 4 12G-SDI OUT 1 - 4 (BNC)
- 5 RETURN IN 1 - 4 (BNC)
- 6 GPIO (D-sub 15pin)
- 7 INTERCOM / TALLY / PGM (D-sub 25pin)
- 8 HD OUT 1 / 2 (BNC)
- 9 REF OUT (BNC)
- 10 TC IN (BNC)
- 11 REF IN (BNC)
- 12 REF LOOP (BNC)

MON (BNC)

The MON BNC connector (1) supplies an SDI monitor output signal with status overlays for essential diagnostic information for the LPS-1. You can configure the output through the Fiber Base Station menu and LPS-1 web UI to show

- A Single Link 3G signal from SDI 1 or 2 inputs to the Fiber Camera Adapter FCA-1 from the ARRI ALEXA 35, or
- A down-scaled, progressive or interlaced signal.

This monitor output can also show the camera status and parameters. Through the LPS-1 web UI the camera status and parameters can be set to a surround view such that the overlay replicates a viewfinder view.

In situations where both SDI 1 & SDI 2 outputs from the camera are in use, this MON output signal including the overlay can be looped back in to the AUX TP IN (2). The signal will appear on the AUX OUT of the Fiber Camera Adapter FCA-1 providing an additional Return Video Channel providing an alternative monitoring solution for e.g. a camera assistant or focus puller

AUX TP IN (BNC)

The AUX TP IN BNC connector (2) is an input for an SDI video signal up to 12G. It is transmitted to the Fiber Camera Adapter FCA-1. You can use it for an additional return video or for a teleprompter.

3G-SDI OUT (1 / 2) (BNC)

The 3G-SDI OUT output BNC connectors (3) are two groups of four SDI outputs each. You can configure them for four single link 3G or one Quad Link 3G for 12G UHD output. You can route the SDI 1 / 2 inputs from the Fiber Camera Adapter FCA-1 to these outputs through the LPS-1 web UI.

12G-SDI OUT (1-4) (BNC)

You can configure the four BNC 12G-SDI output BNC connectors (4) for Single Link SDI signals up to 12G. You can route the SDI 1 / 2 inputs from the Fiber Camera Adapter FCA-1 to these outputs through the LPS-1 web UI.

RETURN IN (1-4) (BNC)

You can connect a Return SDI signal to the RETURN IN input BNC connectors (5) of the Fiber Base Station FBS-1 for transmission to the camera. Format detection is automatic.

You can assign of each of these four Return SDI signals to two separate Return Video controls for selection at the Fiber Camera Adapter FCA-1.

GPI/O (D-Sub 15pin)

GPI/O D-sub 15pin connector (6) for general purpose I/O.

Intercom / Tally / PGM (D-Sub 25pin)

D-Sub 25pin connector (7) for Intercom audio in/out, PGM audio in and Tally control (SONY style connector and pin-assignments).

HD OUT 1 / 2 (BNC)

The HD OUT 1 / 2 output BNC connectors (8) supply down-scaled HD signals (up to 3G) of the SDI 1 & 2 inputs from the Fiber Camera Adapter FCA-1. You can route the signal through the LPS-1 web UI. The output can be a progressive or interlaced format.

REF OUT (BNC)

REF OUT output BNC connector (9) for active genlock output of the analog REF IN (black burst or tri-level sync).

TC IN (BNC)

TC IN input BNC connector (10) for linear timecode input.

REF IN (BNC)

REF IN input BNC connector (11) for genlock signal (black burst or tri-level sync).

REF LOOP (BNC)

REF LOOP output BNC connector (12) of genlock input signal (black burst or tri-level sync).

**NOTICE****Different connector assignments when using HFR**

If you use the HFR functionality, the connector assignment will change. For further information, please see section "Video [▶ 28]".

Section C

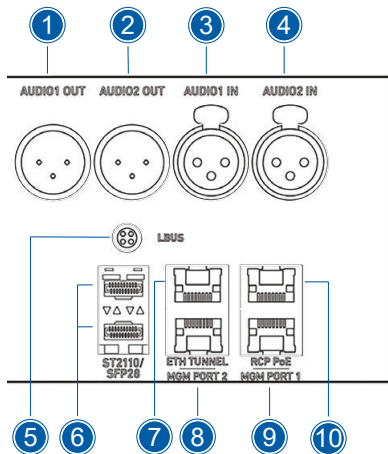

- 1 AUDIO1 OUT (XLR3M)
- 2 AUDIO2 OUT (XLR3M)
- 3 AUDIO1 IN (XLR3F)
- 4 AUDIO2 IN (XLR3F)
- 5 LBUS (Lemo 4pin, not in use)
- 6 ST2110/SFP28 (LC fiber)
- 7 ETH TUNNEL (RJ45)
- 8 MGM PORT 2 (RJ45)
- 9 MGM PORT 1 (RJ45)
- 10 RCP PoE (RJ45)

AUDIO 1 / 2 OUT (XLR3M)

AUDIO OUT (1, 2) XLR 3pin plug (line level or AES) for balanced analog or digital audio.

AUDIO 1 / 2 IN (XLR3F)

AUDIO1 IN (3, 4) XLR 3pin socket (line level or AES) for balanced analog or digital audio.

LBUS (Lemo 4pin, for Service Use)

LBUS Lemo connector (5) for LBUS factory service use only.

ST2110 / SFP28 (LC connector, for Future Use)

The ST2110 / SFP28 interface is a high-speed, 25Gbps data connection. It supports the ST2110 standard for transmitting uncompressed video, audio, and metadata over IP networks. The SFP28 module provides reliable, low-latency transport, making it ideal for connecting devices like cameras, servers, and video routers in modern, IP-based broadcast systems.

ETH TUNNEL (RJ45)

ETH TUNNEL RJ45 connector (7) for auxiliary 1 Gbit/s Ethernet tunnel.

MGM PORT 1 / 2 (RJ45)

MGM PORT 1 / 2 RJ45 connectors (8, 9) to connect to LPS-1 web UI.

RCP PoE (RJ45)

RCP PoE RJ45 connector (10) for remote control panels (supplies power over ethernet).

2.3 Menu Operation

The menu settings are organized in 7 submenus:

Presets	Genlock / Timecode	Video
Network	Intercom	Audio
Diagnostics		

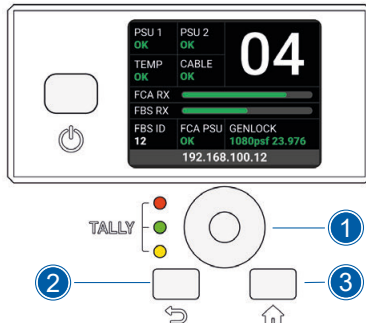

- Turn the *JOGWHEEL* (1) to open and navigate the menu.
- Push the *JOGWHEEL* to open a menu. Push the *BACK* button (2) to return to the previous menu level.
- To edit a setting, push, turn and push the *JOGWHEEL*.
- Push the *HOME* button (3) to return to the HOME screen.

HOME Screen

The HOME screen shows general status information of the system:

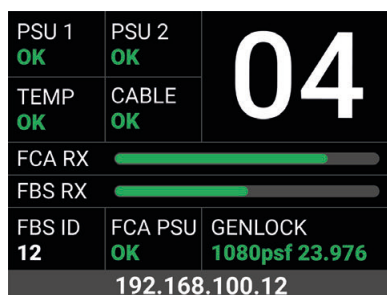

PSU 1 / 2	Status of the power supplies
TEMP	Temperature status
CABLE	Fiber cable status
FCA RX	Fiber Camera Adapter fiber connection quality
FBS RX	Fiber Base Station fiber connection quality
FBS ID	Fiber Base Station ID
FCA PSU	Fiber Camera Adapter power supply status
GEN	Genlock status and format
IP	The IP address of the unit is shown at the bottom of the HOME screen.

CH No. (Channel Number)

The Camera Channel Number assigned by the operator through the LPS-1 web UI for identification of the camera system.

PSU 1/2

Indicates the status of the Fiber Base Station FBS-1 Power Supply Units. This is shown as OK or FAIL indicating that one or more monitored supply rails are not functioning.

TEMP

Indicates the status internal temperatures within the Fiber Base Station FBS-1. This is shown as OK or FAIL indicating that one or more monitored temperatures are deviating from specification. In the case of FAIL being shown you should shut down the system until cooled.

FCA RX

The FCA RX display shows a graphical representation of the transmitted power level received at the Fiber Camera Adapter FCA-1 from the Fiber Base Station FBS-1. The received power can be affected by many factors. The cable length used, the number of interconnections of the cable or perhaps by dust or dirt ingress to a connector. This indication provides a quick reference to establish the integrity of the fiber signal.

FBS RX

The FBS RX display shows a graphical representation of the transmitted power level received at the Fiber Base Station FBS-1 from the Fiber Camera Adapter FCA-1. The received power can be affected by many factors. The cable length used, the number of interconnections of the cable or perhaps by dust or dirt ingress to a connector. This indication provides a quick reference to establish the integrity of the fiber signal.

FBS ID

The Fiber Base Station ID is used by Engineering as a fixed reference to the camera channel that is not changed for operational purposes.

FCA PSU

Indicates the status of the Fiber Camera Adapter FCA-1 Power Supply Unit. This is shown as OK or FAIL indicating that one or more monitored supply rails are not functioning.

GENOCK

The GENLOCK indication provides the status and format of the Genlock signal and allows the operator to make sure that it is present and correct.

3 Fiber Camera Adapter FCA-1

3.1 FCA-1 Control Bay Overview

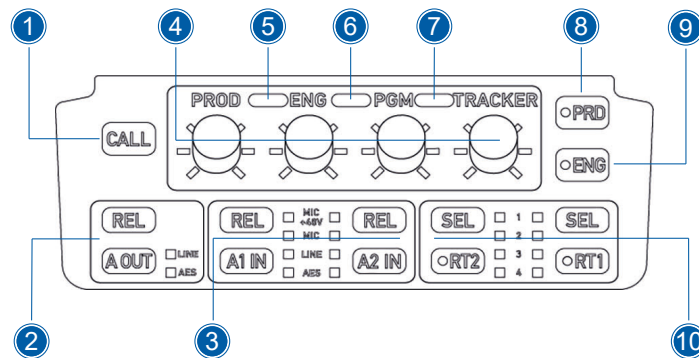

1	CALL Button	5	Red Tally	9	Intercom ENG Button
2	AUDIO OUT Selector	6	Green Tally	10	RETURN IN Selector
3	AUDIO IN Selector	7	Yellow Tally		
4	Volume Controls	8	Intercom PROD Button		

CALL Button

Use the *CALL* button (1) to indicate a call from the camera operator to e.g. the production team. The LED of the *CALL* button reflects the functional status (active call / off).

When activating *CALL* from the FCA Button, you can route the *CALL* signal through the LPS-1 web UI to an output of the GPIO D-sub connector to trigger an external device and flash a *CALL* indicator on RCP.

Audio Out Selector

The audio out selector (2) determines the audio format output at the A OUT connector of the Fiber Camera Adapter FCA-1 (AES or LINE).

- Push and hold the *REL* button (2). Push *A OUT* (2) to toggle between LINE and AES output. The selected format is indicated with a green light.

Audio In Selector

The audio in selectors (3) determine the audio format for the audio inputs A1 IN and A2 IN.

- Push and hold the corresponding *REL* button. Push the *A1 IN* button to select the format for the A1 IN connector (MIC +48 V, MIC, LINE or AES).
- Push and hold the corresponding *REL* button. Push the *A2 IN* button to select the format for the A2 IN connector (MIC +48 V, MIC, LINE or AES).

The selected format is indicated with a green light.

Volume Controls

The *VOLUME* controls (4) adjust the headset volume for the intercom channels, the PGM audio, and the tracker.

Intercom Buttons

The *INTERCOM* buttons (8, 9) activate the headset microphone to talk to the production / engineering channel. The LEDs on the *INTERCOM* buttons show the status (mic activated / de-activated).

- Push the *PRD* button (8) to activate the headset microphone to talk to the production intercom channel. Push the *PRD* button again to de-activate the headset microphone.
- Push the *ENG* button (9) to activate the headset microphone to talk to the engineering intercom channel. Push the *ENG* button again to de-activate the headset microphone.

- Push and hold the *INTERCOM* buttons to activate the headset microphone for as long as the button is pushed.

Return In Selector

You can use the two *RETURN IN* buttons *RT1* and *RT2* to toggle the outputs VF1 and VF2 of the camera viewfinder between live image and return image. Use the *SEL* buttons to determine which return in channel (1 - 4) is shown when you push the buttons. The LEDs adjacent to the *RT1* and *RT2* button indicate the function status (activated / de-activated).

- Push the *SEL* button above the *RT1* / *RT2* button to select which return in channel is shown when you push the *RT1* / *RT2* button.

The selected channel is indicated with a green light.

- Push the *RT1* or *RT2* button to activate return in. The button is latching or momentary (set behavior in the LPS-1 web UI).

- Push and hold the button to activate return in for as long as you push the button.



NOTICE

You can select the behavior (latching / momentary) of the *RT1* / *RT2* buttons in the LPS-1 web UI.

3.2 FCA-1 Connector Bay Overview

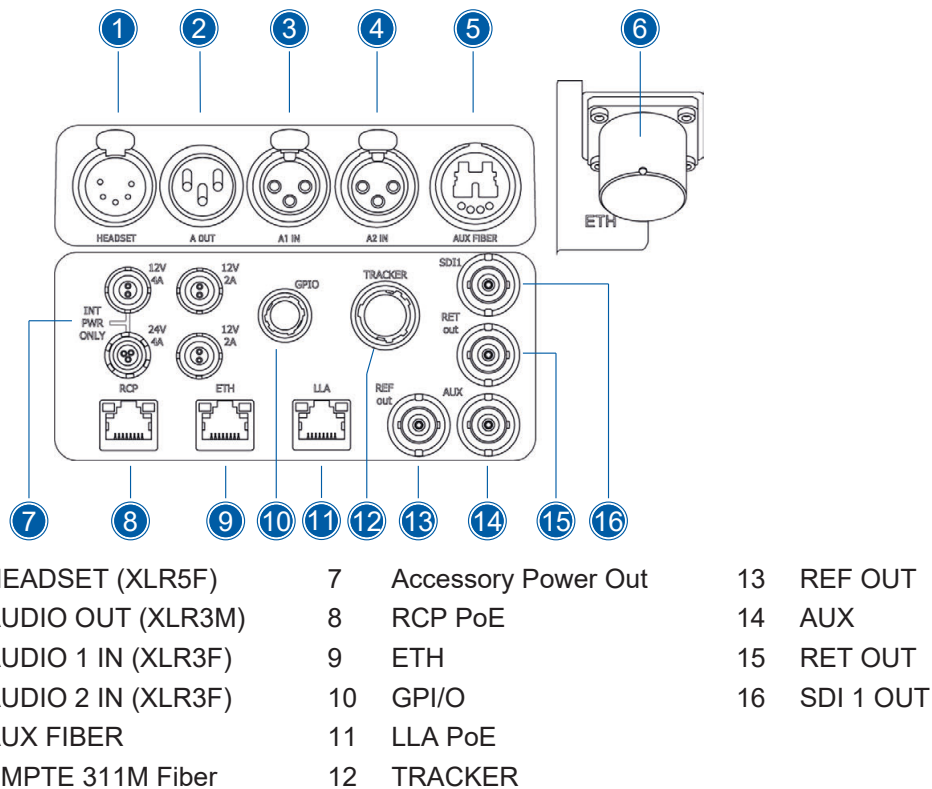

HEADSET Connector (XLR5F)

You can use the XLR 5pin HEADSET socket (1) to connect a headset with dynamic, electret or condenser microphone for intercom communication through the Production and Engineering channels or to monitor the program audio output. When you use a condenser microphone, activate 48 V phantom power.

AUDIO OUT Connector (XLR3M)

XLR 3pin plug (2) for AES or analog line audio output (selectable).

AUDIO 1/2 IN Connectors (XLR3F)

XLR 3pin sockets (3, 4) for audio input (MIC 48 V / MIC / LINE / AES).

AUX FIBER Connector (Neutrik Opticon)

The AUX FIBER connector (5) adds two fiber tunnel connections through the Neutrik Opticon connector. You can connect equipment with a fiber optic interface operating on the 1550 nm wavelength to take advantage of these fiber paths. They are combined with other channels over the length of SMPTE311 or tactical fiber connecting the Fiber Camera Adapter FCA-1 with the Fiber Base Station FBS-1.

For example, when you use an SDI to fiber converter, you can transmit the video from a remote camera connected to the Fiber Camera Adapter FCA-1 AUX Fiber tunnel through the same Fiber cable connecting the Fiber Camera Adapter FCA-1 with the Fiber Base Station FBS-1 and convert back to SDI through a receiver at the Fiber Base Station FBS-1.

**NOTICE**

The fiber tunnel is purely an optical path with minimal loss. The transmission distance is therefore determined by the specification of the optical device connected, taking in to account the overall fiber length between FCA-1 and FBS-1

Fiber Connector (Lemo 3K SMPTE 302M Fiber Connector)

The FIBER Lemo 3K SMPTE 302M fiber connector (6) is the connector for the SMPTE311 or tactical fiber cable leading to the Fiber Base Station FBS-1.

Accessory Power Outputs (Lemo, Fischer)

The Fiber Camera Adapter FCA-1 has the following power outputs (7) with overcurrent protection and automatic recovery for accessories like monitors, teleprompters, lamps, motorized support systems and script boards:

2 x 12 V / 2 A and 1 x 12 V / 4 A Lemo EGG connectors are provided for 12 V accessory power output.

1 x 24 V / 4 A Fischer connector is provided for 24 V accessory power output.

**NOTICE**

When you select the FCA EXT power mode, the power is supplied from the ARRI ALEXA 35. The 12 V / 4 A output and 24 V / 4 A outputs are not functional in this configuration.

RCP PoE Connector (RJ45)

You can use the RCP PoE RJ45 connector (8) for direct RCP connection for diagnostic purpose or for testing video parameter adjustments when the camera is in a remote location far from the Fiber Base Station FBS-1.

ETH Connector (RJ45)

The RJ45 ETH connector (9) for the 1 Gbit/s Ethernet tunnel is an additional connection for devices to connect between Fiber Camera Adapter FCA-1 and Fiber Base Station FBS-1 over the SMPTE311 or Tactical fiber cable.

Example: Ethernet control of a motorized platform or data from a focus assist unit.

GPI/O Connector (Hirose)

The GPI/O connector (10) is an interface that includes inputs and outputs. You can use it to control external equipment. The GPI/O inputs to the Fiber Camera Adapter FCA-1 are pulled up to +5 V. They give a dry contact closure. The GPI/O outputs give a voltage level between -36 and +36 V. You can configure the inputs and outputs through a matrix in the LPS-1 web UI to set up different paths for these signals.

Example: Fiber Camera Adapter FCA-1 GPI 1 could have a switch connected and be mapped to Fiber Base Station GPO 2 to trigger a record start on an external recorder connected to the Fiber Base Station FBS-1.

LLA PoE Connector (RJ45, for Future Use)

RJ45 ethernet connector (11) for a Large Lens Adapter interface module and system diagnostics.

TRACKER Connector (Hirose)

The tracker connector (12) supplies multiple interfaces for another user local to the camera such as focus puller or technician. These include Intercom, Call and Tally indications and GPIO connections that are switched between the Tracker and GPIO connector through the LPS-1 web UI. The pinout mimics the standard from Grass Valley.

REF OUT Connector (BNC)

The REF OUT connector (13) supplies a duplicate signal of the internally generated Genlock/Sync which is Input to the camera. You can use it to synchronize external equipment such as recorders to the same reference signal input to the Fiber Base Station FBS-1.

AUX Connector (BNC)

The LPS-1 system has a different fiber path for an unprocessed SDI signal. Any SDI source (up to 12G UHD) can be transmitted to the Fiber Camera Adaptor. The AUX connector (14) is the output of the signal connected to the AUX Input of the Fiber Base Station FBS-1. You can use it as an additional permanent, non-switching return video signal, Talent monitor, router cross point, multi-viewer or for a teleprompter.

RET OUT Connector (BNC)

The 3G RET OUT output BNC connector (15) supplies a duplicate of the return video input to the camera from the Fiber Base Station FBS-1 for additional monitoring of the active Return Video channel selected.

SDI 1 OUT Connector (BNC)

The 12G SDI 1 OUT BNC connector (16) supplies a duplicate video signal of the camera SDI 1 output. You can use it for additional monitoring, a vanity monitor or where a focus puller is needed.

Generally, SDI 1 is used as the main program video output from the camera and is therefore set as the clean feed in the Monitoring menu of the camera.

If a processed overlay is required for an additional monitor, then SDI 2 output of the camera can be set to processed and the output signal of the FBS-1 connected back in to the AUX input. The additional monitor can then be connected to the AUX out of the Fiber Camera Adapter FCA-1. Alternatively, if SDI 2 out of the camera is also required to have a clean feed, then the MON Out of the Fiber Base Station FBS-1 can be connected to the AUX Input and the surround overlay set by through the LPS-1 web UI.

3.3 Menu Operation

The side display of the Fiber Camera Adapter FCA-1 gives access to different settings. The settings are divided into five pages. Use the navigation at the top of the screen to change between the pages.

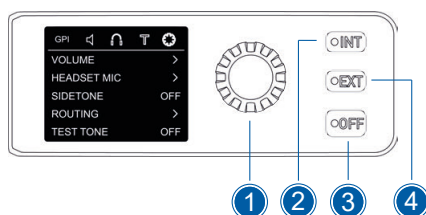

- 1 Jogwheel
- 2 INT Internal Power Button
- 3 Power Off Button
- 4 EXT External Power Button

- Turn the *JOGWHEEL* (1) to select the page (GPI, Audio, Intercom, Tracker, Settings).
- Push the *JOGWHEEL* to access a page.

- Turn the *JOGWHEEL* to scroll up or down within the page.
- Push the *JOGWHEEL* to edit a setting. Then turn the jog wheel (1) to select the correct value. Push the *JOGWHEEL* to confirm the change.
- Scroll up into the navigation bar and push the *JOGWHEEL* to leave a page.

To Energize and De-energize the Fiber Camera Adapter FCA-1

The Fiber Camera Adapter FCA-1 boots up when power is supplied on the SMPTE311 fiber cable as default.

- Push the *INT* button (2) to energize the Fiber Camera Adapter FCA-1 from the SMPTE311 fiber cable.
- Push the *EXT* button (4) to energize the Fiber Camera Adapter FCA-1 from the external power input of the camera.
- Push and hold the *OFF* button (3) to de-energize the Fiber Camera Adapter FCA-1 and camera.



NOTICE

The power on and boot up of the system takes approximately 1 minute. A soft reset from the LPS-1 web UI takes approximately 45 seconds. This is normal and should be considered during a production.

HOME Screen

The HOME Screen of the Fiber Camera Adapter FCA-1 shows general status information of the system. The HOME screen is shown 20 seconds after the last menu action automatically.

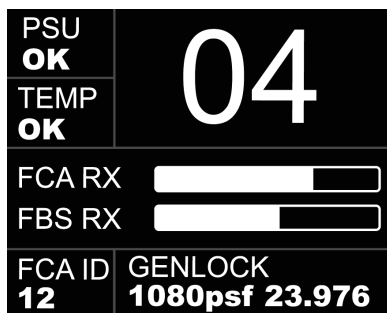

PSU	Status of the Fiber Camera Adapter power supply
TEMP	Temperature status
FCA RX	Fiber Camera Adapter fiber connection quality
FBS RX	Fiber Base Station fiber connection quality
FCA ID	Fiber Camera Adapter ID
GENLOCK	Genlock status and format

CH No. (Channel Number)

The Camera Channel Number assigned by the operator through the LPS-1 web UI for identification of the camera system.

PSU

Indicates the status of the Fiber Camera Adapter Power Supply Unit. This is shown as OK or FAIL indicating that one or more monitored supply rails are not functioning.

TEMP

Indicates the status internal temperatures within the Fiber Camera Adapter FCA-1. This is shown as OK or FAIL indicating that one or more monitored temperatures are deviating from specification. In the case of FAIL being shown you should shut down the system until cooled.

FCA RX

The FCA RX display shows a graphical representation of the transmitted power level received at the Fiber Camera Adapter FCA-1 from the Fiber Base Station FBS-1. The received power can be affected by many factors. The cable length used, the number of interconnections of the cable or perhaps by dust or dirt ingress to a connector. This indication provides a quick reference to establish the integrity of the fiber signal.

FBS RX

The FBS RX display shows a graphical representation of the transmitted power level received at the Fiber Base Station FBS-1 from the Fiber Camera Adapter FCA-1. The received power can be affected by many factors. The cable length used, the number of interconnections of the cable or perhaps by dust or dirt ingress to a connector. This indication provides a quick reference to establish the integrity of the fiber signal.

FCA ID

The Fiber Camera Adapter ID is used by Engineering as a fixed reference to the camera channel that is not changed for operational purposes.

GENLOCK

The GENLOCK indication provides the status and format of the Genlock signal and allows the operator to make sure that it is present and correct.

4 Skaarhoj RCP Pro ARRI V2B

The SKAARHOJ RCP Pro ARRI V2B uses the ARRI Camera Access Protocol for traditional live painting and full control over camera settings like frame rate, REC start / stop, playback, the selection of looks, ARRI Textures, and setup files.

Please find detailed information about setup and use of the SKAARHOJ RCP Pro ARRI V2B in the user documentation which is shipped with the device.

4.1 Skaarhoj RCP Pro ARRI V2B Installation

The SKAARHOJ RCP Pro ARRI V2B connects to the Fiber Base Station FBS-1 through the RCP PoE connector on the front side or rear side of the FBS-1.

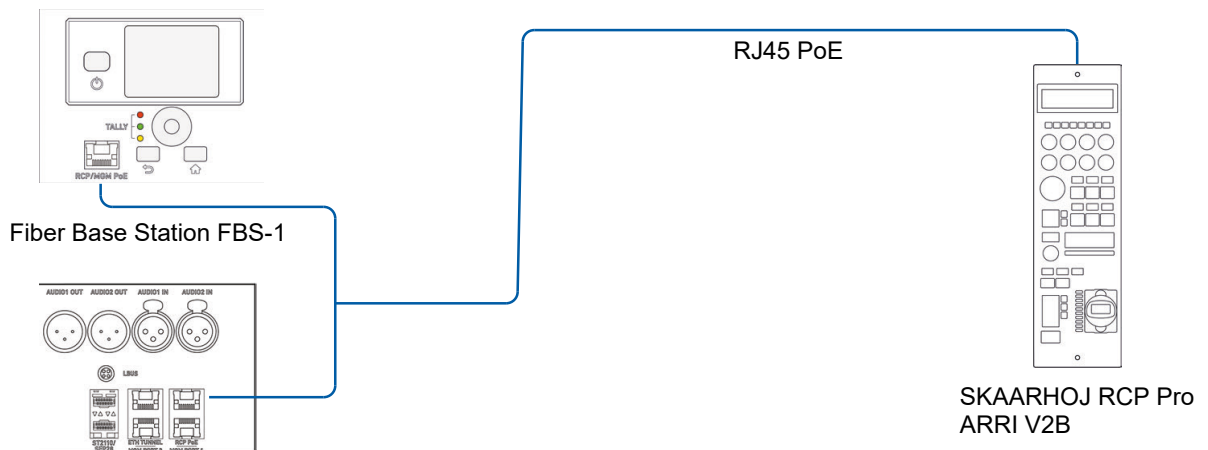

5 System Setup

5.1 Power Supply

With a SMPTE311 fiber cable you can supply power to the camera and the Fiber Camera Adapter FCA-1 through the Fiber Base Station FBS-1. With a tactical fiber cable that does not transmit power, you shall supply power to the camera and Fiber Camera Adapter FCA-1 locally through the camera.

Internal Power Supply Through SMPTE311 Hybrid Fiber Cable

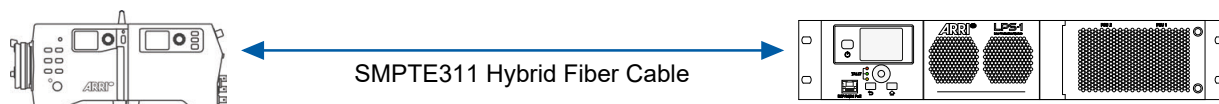

External Power Supply Using a Tactical Fiber Cable

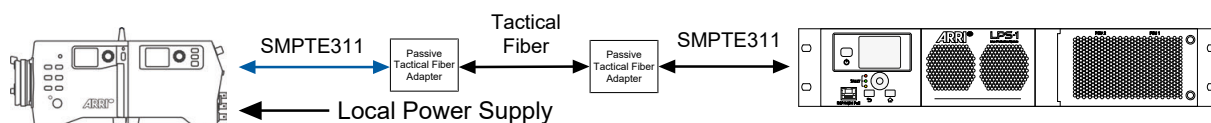

Power Source	Steps	Notes
SMPTE311 / Fiber Base Station	1. Connect the SMPTE311 fiber cable to the Fiber Base Station FBS-1 and the Fiber Camera Adapter FCA-1 .	SMPTE311 fiber cables supply both power and data.
	2. Push <i>POWER</i> on the Fiber Base Station FBS-1 to energize the system.	The Fiber Base Station FBS-1, Fiber Camera Adapter FCA-1 and the camera will be energized the same time.
	3. To de-energize the entire system, push and hold <i>POWER</i> on the Fiber Base Station FBS-1 .	
	4. To de-energize the Fiber Camera Adapter FCA-1 and the camera, push and hold <i>OFF</i> on the Fiber Camera Adapter FCA-1 .	Push <i>INT</i> on the Fiber Camera Adapter FCA-1 to energize the Fiber Camera Adapter FCA-1 and the camera.
Locally through the camera	1. Connect the external power source to the camera.	A Tactical fiber cable does not supply power.
	2. Push <i>EXT</i> on the Fiber Camera Adapter FCA-1 to energize the system.	The Fiber Camera Adapter FCA-1 and camera will energize. Please note that the 12 & 24 V /4 A outputs will be deactivated when using external power.
	3. To de-energize the Fiber Camera Adapter FCA-1 and camera, push and hold <i>OFF</i> on the Fiber Camera Adapter FCA-1 .	
To switch between power sources	1. When both power sources are connected, push <i>EXT</i> to use the local power source from the camera.	You can perform this action during operation.
	2. Push <i>INT</i> to use the Fiber Base Station FBS-1 as power source.	

5.2 Camera Configuration

The ARRI ALEXA 35 Software Update Package SUP 6.0.0 introduced default Multicam set ups that allow the user to quickly set up the camera for typical multicam use in 50/59.94 or 60P through a single camera menu selection. We recommended to use these default set ups as a reference point to begin with and then, if necessary, make adjustments specific to the particular project.

The tables below show the typical camera-related configurations you may wish to review and adjust when you prepare the camera for use with the Live Production System LPS-1. For more detailed information, please refer to the ARRI ALEXA 35 user manual. It is available for download in the [ARRI Documentation Portal](#). Please note that the menu may vary with different camera software versions.

Recording and Project Setting

Menu Path	Setting	Description
<i>MENU > Recording > Recording Codec</i>	e.g. <i>ProRes 422 HQ</i>	Select the correct recording codec.
<i>MENU > Recording > Sensor Mode</i>	e.g. <i>3.8K 16:9</i>	Set the correct sensor mode.
<i>MENU > Recording > Project Settings > Project Rate</i>	e.g. <i>50p</i>	Set the correct project frame rate.
<i>HOME > Timecode > Options > Timecode Mode</i>	<i>Regen (LPS-1)</i>	Sets the camera to receive the timecode from the Fiber Base Station.
<i>HOME > FPS</i>	e.g. <i>50.000</i>	Set the correct sensor frame rate. Should match project frame rate for sync speed.
<i>MENU > Recording > Audio Recording</i>	<i>enabled</i>	Activate internal audio recording (if applicable).
<i>MENU > Recording > Audio Recording > Channel 1 Source</i>	<i>LPS-1 CH1</i>	Audio channel 1 of the camera is supplied through the FBS-1 and the audio matrix.
<i>MENU > Recording > Audio Recording > Channel 2 Source</i>	<i>LPS-1 CH2</i>	Audio channel 2 of the camera is supplied through the FBS-1 and the audio matrix.
<i>MENU > Recording > Audio Recording > VF Headphones Routing > Channel 1</i>	<i>L</i>	Audio Channel 1 of the camera is output on the headphones left.
<i>MENU > Recording > Audio Recording > VF Headphones Routing > Channel 2</i>	<i>R</i>	Audio Channel 2 of the camera is output on the headphones right.

Image Output Configuration

Menu Path	Setting	Description
<i>MENU > Monitoring > SDI > SDI 1 Image</i>	<i>Clean</i>	Select the correct recording codec.
<i>MENU > Monitoring > SDI > SDI 1 Format</i>	e.g. <i>422 12G UHD</i>	Set the correct sensor mode.
<i>MENU > Monitoring > SDI > SDI 1 Frame Rate</i>	e.g. <i>50p</i>	Set the correct project frame rate.
<i>MENU > Monitoring > Return In > Use SDI 2 as Return In</i>	<i>enabled</i>	Camera receives the Return Video Signal from the Fiber Base Station.
<i>MENU > Monitoring > Return In > Show Return In on SDI 1</i>	<i>disabled</i>	Where SDI 1 is used for Program video, set this to disabled to avoid any disruption to image when switching Return Video.

System Settings

Menu Path	Setting	Description
<i>MENU > System > Shutter Unit</i>	<i>Exposure Time</i>	Set the shutter unit to exposure time.
<i>MENU > System > Sensor > Genlock Sync</i>	<i>Sync In</i>	Activate Genlock synchronization. The camera now requires a tri-level or black burst signal for synchronization (from the Fiber Base Station).
<i>MENU > System > Buttons+Display > Tally</i>	<i>On (Remote/ CAP)</i>	All tally lights connected to the camera are controlled or remotely operated through the Fiber Base Station instead of Record.

Image Settings

Menu Path	Setting	Description
<i>MENU > Image > Look > Look</i>	<i>Multicam Default</i>	The 'Multicam Default' Look allows the user to make adjustments to camera parameters whereas the default look does not.
<i>MENU > Image > Look > Live Painting</i>	<i>enabled</i>	Shall be enabled to allow adjustments of camera parameters from RCP.
<i>MENU > Image > Texture > Texture</i>	<i>Multicam MCS0</i>	Set the Texture. Textures Multicam MCS0 - MCS5 are intended to be used with the Live Production System.
<i>MENU > Image > Texture > Texture > Delete</i>		Remove all unnecessary or unused textures from the list, keeping only Textures Multicam MCS0 - MCS5.

Monitoring (Operator)

These settings determine how the camera image is shown on the MVF-2 viewfinder and on a CCM-1 or LPM-1 monitor. Options range from a clean image to additional overlays and status information, with the choice of logarithmic representation or color-adjusted output. Some settings are subject to the operator's preferences, and additional configuration options are available. For more details, please refer to the camera's user manual.

Menu Path	Setting	Description
<i>MENU > Monitoring > VF > Surround View</i>	<i>Off</i>	Activate / de-activate Surround View.
<i>MENU > Monitoring > VF > EVF Overlays > Center Mark</i>	<i>Off + Colored Line</i>	Info: With Surround View set to On, the live preview scaling may differ from the return-in image size, leading to a less smooth experience when switching between them.
<i>MENU > Monitoring > VF > EVF Overlays > Status Info</i>	<i>Off</i>	Activate / De-activate a center mark.
<i>MENU > Monitoring > VF > EVF Overlays > Status Components > Lens Data</i>	<i>Off or Overlay</i>	Activate / De-activate Status Info.
<i>MENU > Monitoring > VF > EVF Overlays > Status Components > Depth of Field</i>	<i>enable</i>	Info: With Status Info set to Safe, the live preview scaling may differ from the return-in image size, leading to a less smooth experience when switching between them.

User Buttons

Menu Path	Setting	Description
<i>MENU > User Buttons > Lens User Buttons > Lens RET 1</i>	<i>RT1</i>	Access the <i>RT1</i> button of the Fiber Camera Adapter FCA-1 through the Zoom Demand, to toggle between the live image and Return 1.
<i>MENU > User Buttons > Lens User Buttons > Lens RET 2</i>	<i>RT2</i>	Access the <i>RT2</i> button of the Fiber Camera Adapter FCA-1 through the Zoom Demand, to toggle between the live image and Return 2.
<i>MENU > User Buttons > Lens User Buttons > Lens ENG</i>	<i>ENG</i>	Access the <i>ENG</i> button of the Fiber Camera Adapter FCA-1 through the Zoom Demand.
<i>MENU > User Buttons > Lens User Buttons > Lens PROD</i>	<i>PRD</i>	Access the <i>PRD</i> button of the Fiber Camera Adapter FCA-1 through the Zoom Demand.

5.3 Network Setup

Since the introduction of the LPS-1 SUP 1.3.0 Software Update Package, the Fiber Base Station FBS-1 supports automatic detection of the IP address of the connected Fiber Camera Adapter FCA-1 and ARRI ALEXA 35 Live.

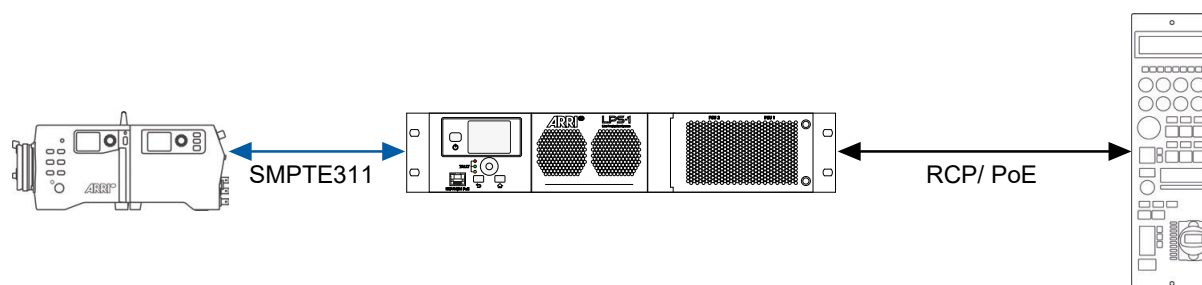

To configure the network for the system, perform the following steps:

Camera Network Setup through the Camera Menu

Menu Path	Setting	Description
<i>MENU > System > Network / WiFi > LAN IP Mode</i>	<i>DHCP</i>	Set the LAN IP Mode to <i>DHCP</i> .
<i>MENU > System > Network / WiFi > LAN Static IP</i>	e.g. <i>192.168.1.12</i>	Set the IP address of the camera (optional when using a Static IP address).
<i>MENU > System > Network / WiFi > LAN Static Subnet</i>	e.g. <i>255.255.255.0</i>	Set the subnet mask (optional when using a Static IP address).
<i>MENU > System > Network / WiFi > LAN Static Gateway</i>	e.g. <i>192.168.1.1</i>	Set the default gateway (optional when using a Static IP address).
<i>MENU > System > Camera Access Protocol (CAP) > CAP Server Password</i>		Set a password for the CAP server. The default password is arri .

Fiber Base Station Network Configuration through the front panel FBS-1 Menu

Configure the network related features of the LPS-1 system in the network menu of the Fiber Base Station FBS-1.

➤ Select *HOME > Network* in the FBS-1 menu.

Please find the detailed menu structure in section "Network Settings [▶ 47]".

Network Configuration through the LPS-1 web UI

By connecting a PC / MAC to one of the MGM ports of the system you can access the LPS-1 web UI. In a browser, enter the assigned Static IP address of the FBS-1 (default is 192.168.1.10).

➤ Select *HOME > Network* in the LPS-1 web UI.

SKAARHOJ RCP Pro ARRI V2B Network Setup

The IP address of the RCP Pro is shown on the central display above the joystick during start-up. Alternatively, push the SETUP button on the RCP Pro two times to show the IP address in the main display at the top of the panel.

Enter the IP address of the SKAARHOJ RCP Pro ARRI V2B in the address bar of a web browser to open the SKAARHOJ web UI. The default credentials are **User: admin** and **Password: Skaarhoj**.

From the 'Reactor' web User Interface, the IP address of the RCP can then be set as required and from the Home page, the 'ALEXA 35 via LPS-1' added as the device.

Menu Path	Setting	Description
SETTINGS > IP Configuration > IP Address	e.g. 192.168.1.13	Set the IP address of the RCP (default: 192.168.1.13).
SETTINGS > IP Configuration > Subnet Mask	e.g. 255.255.255.0	Set the subnet mask.
SETTINGS > IP Configuration > Gateway	e.g. 192.168.1.1	Set the default gateway.
HOME > Devices > Add Device > Add Manually		Add the 'ALEXA 35 via LPS-1' from the device list.

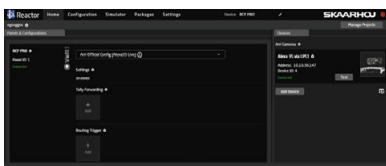

With the 'ALEXA 35 via LPS-1' added as the device, the configuration can then be selected as 'Arri Official Config (ALEXA35 Live)'.

For additional technical resources for the Skaarhoj RCP please visit <https://wiki.skaarhoj.com/>.

5.4 Video

Overview of Video Inputs and Outputs

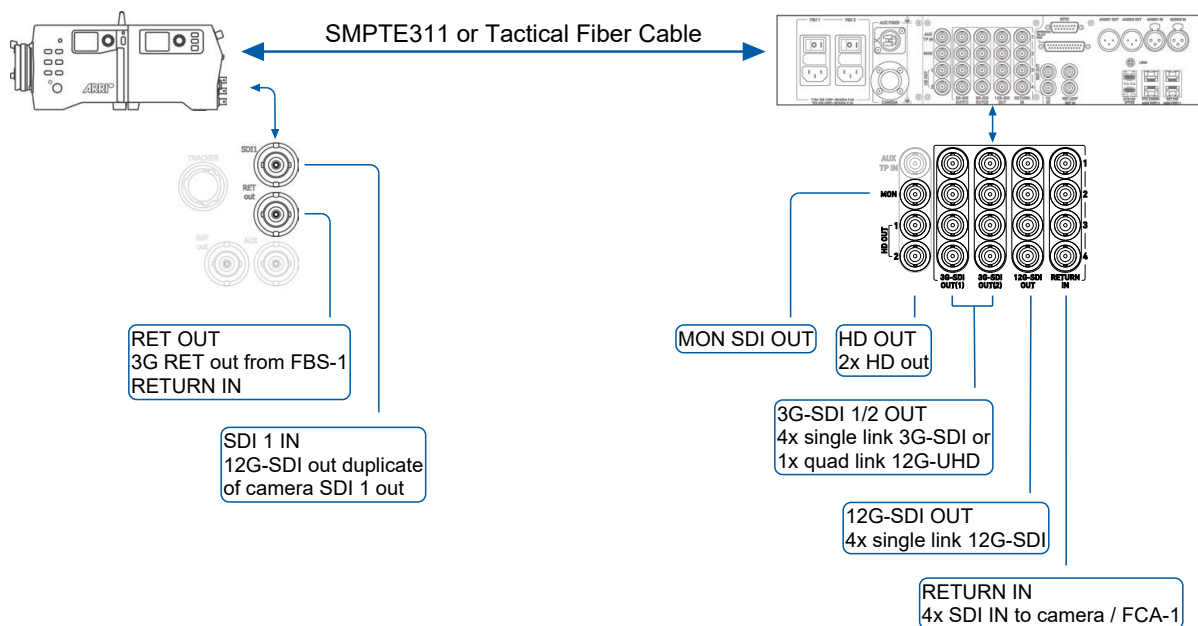

LPS-1 Web UI Video Matrix

Through the LPS-1 web UI, it is possible to route the SDI 1 and SDI 2 outputs of the camera different outputs of the Fiber Base Station FBS-1. Additionally, you can route the downscaled HD Out 1 & 2 to the 3G SDI OUT (1) and 3G SDI OUT (2) banks. These down scaled outputs can also be set to interlaced formats.

The Video Matrix shows the routing of the video inputs and video outputs.

➤ Select *HOME* > *Video Matrix* in the LPS-1 web UI to open the Video Matrix.

Click on a *currently set* assignment to delete the assignment.

Click on a *currently not set* assignment to set the assignment.

Fixed by system assignments cannot be changed.

For example, it is possible to set the camera to output an HDR signal on SDI 1 and route the signal to the 12G outputs of the FBS-1 whilst SDI 2 out of the camera is set to REC 709 and routed to the 3G outputs.

Video Inputs

The **Fiber Base Station FBS-1** has four RETURN IN inputs which are transmitted to the Fiber Camera Adapter FCA-1. Format detection is automatic.

The **Fiber Camera Adapter FCA-1** has two SDI inputs on the right side. Both inputs are connected to the SDI 1 / 2 outputs of the camera when the FCA-1 is attached to the camera. For more detailed information, please see the LPS-1 operating manual. The operating manual is available for free download at the [ARRI documentation portal](#).

Video Outputs

See "FBS-1 Rear Panel Overview [▶ 8]". The **Fiber Base Station FBS-1** has fifteen video outputs on the rear. The video outputs are organized in three groups:

HD OUT 1 / 2 and MONITOR Outputs

The HD OUT 1 / 2 and MONITOR outputs supply down-scaled HD signals (up to 3G) of the SDI 1 / 2 inputs from the Fiber Camera Adapter FCA-1. You can route the down scaled HD signal through the LPS-1 web UI Video Matrix and configure them to either progressive or interlaced video formats. When operating in HFR Mode, a fixed configuration is applied and these outputs provide the Live output.

3G-SDI 1/2 Outputs

Both 3G-SDI out groups can output four single link 3G-SDI signals or one quad link 3G-SDI signal each. It is also possible to route the HD Out 1/2 down scaled video signals to these 3G-SDI outputs. When operating in HFR Mode, a fixed configuration is applied and these outputs provide the different phases for input to a slow motion playout server (see "Video [▶ 28]").

12G SDI Outputs (1-4)

The four 12G-SDI outputs can supply for Single Link SDI signals up to 12G. You can route the SDI 1 / 2 inputs from the Fiber Camera Adapter FCA-1 to these outputs through the LPS-1 web UI Video Matrix. When operating in HFR Mode, a fixed configuration is applied and outputs 1 & 2 become the Live Output whilst Outputs 3 & 4 provide Even and Odd frames to produce a 120fps frame rate for input to a slow-motion playout server (see "Video [▶ 28]").

Additionally, the Fiber Camera Adapter FCA-1 has one SDI and one RET OUT output for monitoring. See "FCA-1 Connector Bay Overview [▶ 15]".

The SDI 1 output of the camera is available at the SDI 1 output of the Fiber Camera Adapter FCA-1.

The RET OUT output duplicates the return video input to the camera from the Fiber Base Station FBS-1.

Video Configuration through the front panel FBS-1 Menu

> Select *HOME* > *Video* in the FBS-1 menu.

Please find the detailed menu structure in section "Video Settings [▶ 48]".

Video Configuration through the LPS-1 Web UI

> Select *HOME* > *Video* in the LPS-1 web UI.

FCA Return Video

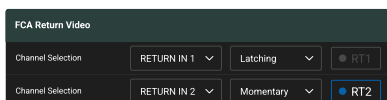

The FCA Return Video area defines the behavior of the RT1 / RT2 button in the RETURN IN section of the Fiber Camera Adapter FCA-1 control bay.

FBS Video Output Configuration

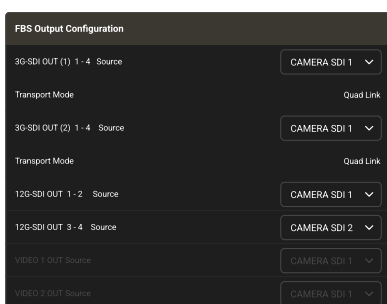

In the FBS Output Configuration area you can assign the input video signals to the video output connectors of the Fiber Base Station FBS-1.

FBS Return Input Configuration

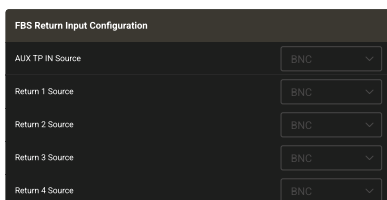

The return input configuration area determines the source of the return input channels of the Fiber Base Station FBS-1.

AUX TP IN is routed to the AUX connector of the Fiber Camera Adapter FCA-1.

RETURN 1 – 4 is routed to the RETURN IN selector of the Fiber Camera Adapter FCA-1. The RETURN IN selector determines which return in channel (1 – 4) is routed to the output VF1 and VF2 of the camera.

FBS Downconverter Configuration HD OUT 1 / 2

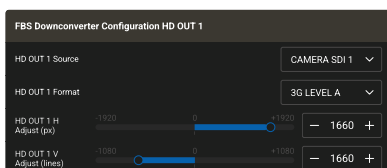

The HD OUT 1 / 2 outputs supply down-scaled HD signals of the SDI 1 / 2 inputs from the Fiber Camera Adapter FCA-1. You can do all downconverter settings in the HD OUT 1 / 2 Downconverter Configuration area.

FBS Signal Generator

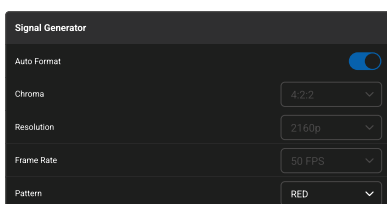

You can define a test signal in the Signal Generator area. The test signal is sent to the output(s) set in the Video Matrix (see below). When no video is received from the ARRI ALEXA 35 Live the system will show the test pattern on the output and provides an informative text overlay with the information of which output is connected, the camera channel number, FBS ID number and the LPS-1 configuration preset in use. You can toggle the shown text ON/OFF.

FBS Monitor Status Display

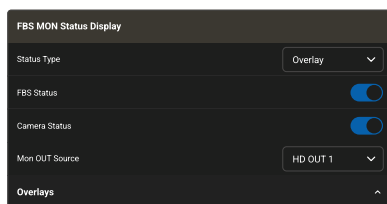

The FBS Monitor output can have an overlay showing both LPS-1 and camera status information. The Monitor Status Display area shows all options you can show in the overlay. This can also be set to a surround view which replicates camera viewfinder showing status and video parameters.

Toggle All On/Off expands or collapses the full list of options.

Available Options:

<i>FCA / FBS RX Bargraph</i>	Fiber connection quality (Fiber Camera Adapter FCA-1 and Fiber Base Station FBS-1)
<i>FBS PSU 1</i>	PSU 1 status of the Fiber Base Station FBS-1
<i>FBS PSU 2</i>	PSU 2 status of the Fiber Base Station FBS-1
<i>FBS Temperature</i>	Internal temperature of the Fiber Base Station FBS-1
<i>FCA Temperature</i>	Internal temperature of the Fiber Camera Adapter FCA-1
<i>FBS Fan</i>	Fan status of the Fiber Base Station FBS-1
<i>FCA Fan</i>	Fan status of the Fiber Camera Adapter FCA-1
<i>FBS IP Address</i>	IP address of the Fiber Base Station FBS-1
<i>FCA IP Address</i>	IP address of the Fiber Camera Adapter FCA-1
<i>Camera Channel</i>	Channel of the connected camera
<i>Camera RCP</i>	Remote control used for the connected camera
<i>Genlock</i>	Genlock status and information
<i>FBS ID</i>	ID number of the Fiber Base Station FBS-1
<i>FCA PSU</i>	PSU status of the Fiber Camera Adapter FCA-1
<i>FCA Call</i>	Indicates a call from the camera operator to the production team
<i>Tally</i>	Tally status

High Frame Rate SDI Output

With the introduction of SUP 6.1.0 for the ARRI ALEXA 35 and SUP 1.4.1 of the LPS-1 the ARRI ALEXA 35 Live - Multicam System supports output of HFR (high frame rate) video through SDI for slow-motion images in live events through an HFR-enabled playout server.

With the High Frame Rate SDI feature (HFR SDI), the camera supports high-speed image transmission through its two 12G SDI outputs. It supports both HD-based subframe packing and native UHD output.

Depending on the set sensor mode and the selected sensor frame rate, either one (SDI 1) or both SDI outputs are used for this purpose.

The transmission is based on a standard 12G-SDI physical layer that complies with SMPTE ST 2082-10. It follows the principles of multi-stream transport derived from SMPTE ST 2082-30:2017 (Mode 2.) HD formats comply with SMPTE ST 274 and SMPTE ST 425-1 Level A (1920×1080, 4:2:2, 10-bit).

Certain conditions need to be observed to use HFR SDI:

- Set the Sensor Mode and Recording Resolution to a 16:9 aspect ratio:
 - 4K 16:9 - UHD (3840x2160)
 - 4K 16:9 - HD (1920x1080)
 - 3.8K 16:9 - UHD (3840x2160)
 - HD 16:9 S16 - HD (1920x1080)
 - Set the Project Rate to 50p, 59.94p or 60p
- Select *MENU > Monitoring > SDI > HFR SDI* to activate HFR SDI.

Available options:

Off 2x 3x 4x 5x 6x 7x 8x

The factor represents a multiple of the set project rate. For example, if the project rate is 60p, a factor of 4x results in a sensor frame rate and SDI transmission of 240 fps. The availability of individual factors depends on the selected sensor mode, project rate, recording codec, and active sensor overdrive. Frame rates up to 330 fps benefit from the camera’s full dynamic range of 17 stops, while a Sensor Overdrive mode allows frame rates up to 480 fps at a dynamic range of 11 stops.

Sensor Mode / Recording Resolution	Recording Codec	Sensor Overdrive	Project Rate	Available Factors
4K 16:9 – UHD (3840 x 2160)	Apple ProRes	n/a	50P, 59.94P, 60P	2x
4K 16:9 – HD (1920 x 1080)	Apple ProRes	n/a	59.94P, 60P	2x
			50P	2x, 3x
3.8K 16:9 – UHD (3840 x 2160)	Apple ProRes ARRIRAW ARRICORE	n/a	50P, 59.94P, 60P	2x
HD 16:9 S16 – HD (1920 x 1080)	Apple ProRes ARRIRAW	n/a	59.94P, 60P	2x, 3x, 4x, 5x
	ARRIRAW		50P	2x, 3x, 4x, 5x, 6x
	ARRICORE	Off	59.94P, 60P	2x, 3x, 4x, 5x
		On	59.94P, 60P	6x, 7x, 8x
			50P	7x, 8x

The LPS-1 system automatically detects this high frame rate SDI input from the camera and is configured accordingly. The system can output HFR at speeds of up to 8x in HD or 2x in UHD for input to a slow motion server. Whatever frame rate is chosen for the slow-motion feed, the system simultaneously provides a live feed for broadcast, allowing operators to switch between the program frame rate and HFR feed in real time. This live feed is created from one or more of the phases used for the high frame rate output. An adjustment through the LPS-1 web UI allows users to select whichever combination of phases most effectively reduces motion blur and shutter effects to match other cameras or suit different environments.

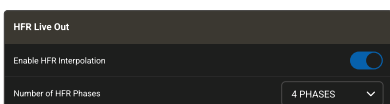

Enable HFR Interpolation activates or de-activates HFR interpolation

Number of HFR Phases determines the number of phases the 3G signal contains.

When operating in HFR Mode, the Fiber Base Station outputs are configured according to the detected resolution and frame rate.

FBS-1 Outputs in UHD 12G HFR Operation

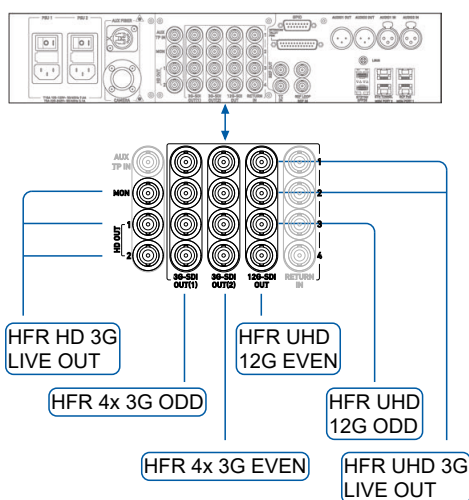

FBS-1 Outputs in 3G HFR Operation

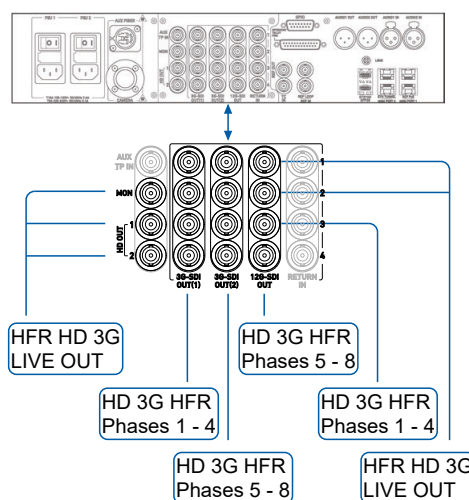



NOTICE

The ALEXA 35 Live High Frame Rate SDI License is compatible with ARRI's ALEXA 35 Live Xtreme and ALEXA 35 Live (Xtreme-ready, 2026 onwards) cameras. It requires both the High Frame Rate SDI License and the High Speed License (also included in the Cine Plus and Premium Licenses) to be installed. The ARRI service department can upgrade ALEXA 35 Live (pre-2026) cameras to make them Xtreme-ready.

You can purchase licenses directly from the ARRI License Shop <https://shop.arri.de/catalog>.

5.5 Audio

Overview of Audio Inputs and Outputs

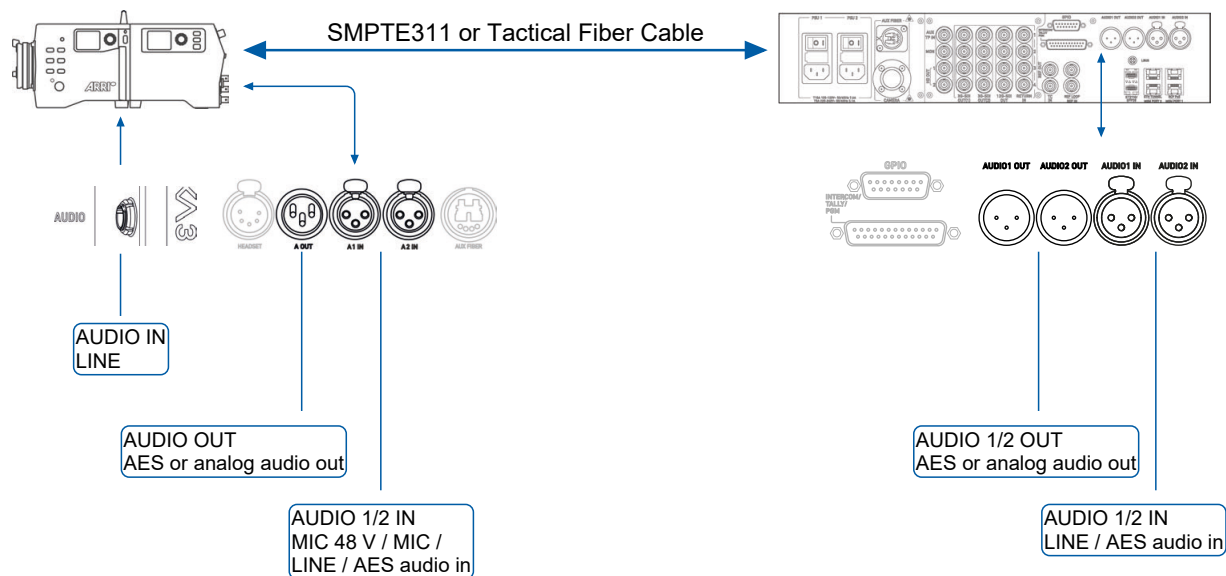

Audio Inputs

See "FBS-1 Rear Panel Overview [▶ 8]". The **Fiber Base Station FBS-1** has three audio inputs on the rear. You can use the two XLR3M inputs AUDIO1 IN and AUDIO2 IN as AES or LINE In inputs.

You can set the format (AES or LINE) of the AUDIO1 IN and AUDIO2 IN inputs in the AUDIO submenu of the Fiber Base Station menu or the LPS-1 Web UI.

See "FCA-1 Connector Bay Overview [▶ 15]". The **Fiber Camera Adapter FCA-1** has two XLR3M inputs A1 IN and A2 IN. You can use them as AES, LINE or MIC inputs.

➤ Push and hold the corresponding *REL* button. Then push the *A1 IN* button to select the format for the A1 IN connector (MIC +48 V, MIC, LINE or AES).

➤ Push and hold the corresponding *REL* button. Then push the *A2 IN* button to select the format for the A2 IN connector (MIC +48 V, MIC, LINE or AES).

The selected format is indicated with a green light.

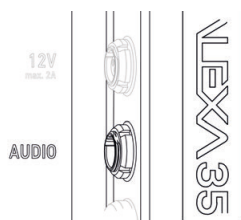

The camera can receive audio signals from the Fiber Camera Adapter / Fiber Base Station through an interface on the rear. Additionally the **ALEXA 35** has an AUDIO connector on the right side of the camera. It is a two channel +24 dBu line level audio input with 12 V power output to supply microphone pre-amplifiers that can be used to provide a total of 4 channels.

Audio Outputs

See "FBS-1 Rear Panel Overview [▶ 8]". The **Fiber Base Station FBS-1** has two XLR3F outputs AUDIO1 OUT and AUDIO2 OUT on the rear. You can use them as an AES or LINE output.

You can set the format (AES or LINE) of the AUDIO1 OUT and AUDIO2 OUT outputs in the AUDIO sub-menu the Fiber Base Station menu or the LPS-1 web UI.

See "FCA-1 Connector Bay Overview [▶ 15]". The **Fiber Camera Adapter FCA-1** has an XLR3F output A OUT and an XLR5F Headset output. You can use the A OUT output as an AES or LINE output.

Push and hold the *REL* button. Push the *A OUT* button to toggle between LINE and AES output.

The selected format is indicated with a green light.

The **ALEXA 35** transmits audio signals to the fiber camera adapter through an interface on the rear of the camera and through the SDI stream.

Audio Configuration through the front panel FBS-1 Menu

▶ Select *HOME* > *Audio* in the FBS-1 menu.

Please find the detailed menu structure in section "Audio Settings [▶ 47]".

Audio Configuration through the LPS-1 Web UI

▶ Select *HOME* > *Audio* in the LPS-1 web UI.

FBS Audio In



The FBS Audio In area determines the Audio In

- Format,
- Level, and
- Attenuation

of the AUDIO IN 1 / 2 inputs of the Fiber Base Station FBS-1.

FBS Audio Out

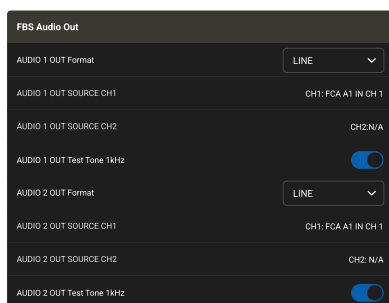

The FBS Audio Out area determines the Audio Out

- Format, and
- Source

of the AUDIO OUT 1 / 2 outputs of the Fiber Base Station FBS-1.

You can activate a 1 kHz test tone for both output channels to check your signal routing.

FCA Audio In

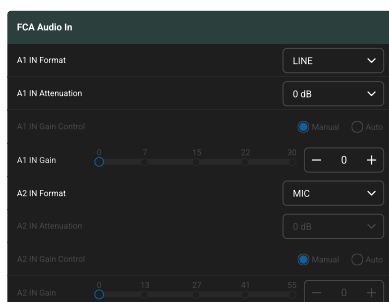

The FCA Audio In area determines the Audio In

- Format,
- Level,
- Attenuation,
- Gain Control, and
- Gain

of the AUDIO IN 1 / 2 inputs of the Fiber Camera Adapter FCA-1.

FCA Audio Out

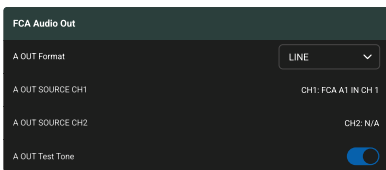

The FCA Audio Out area determines the Audio Out

- Format, and
- Source

of the AUDIO OUT output of the Fiber Camera Adapter FCA-1.

You can activate a 1 kHz test tone on the output channel to check your signal routing.

Audio Matrix

The Audio Matrix shows the routing of the audio inputs and audio outputs.

➤ Select *HOME* > *Audio Matrix* in the LPS-1 web UI to open the Audio Matrix.

Click on a *currently set* assignment to delete the assignment.

Click on a *currently not set* assignment to set the assignment.

Fixed by system assignments cannot be changed.

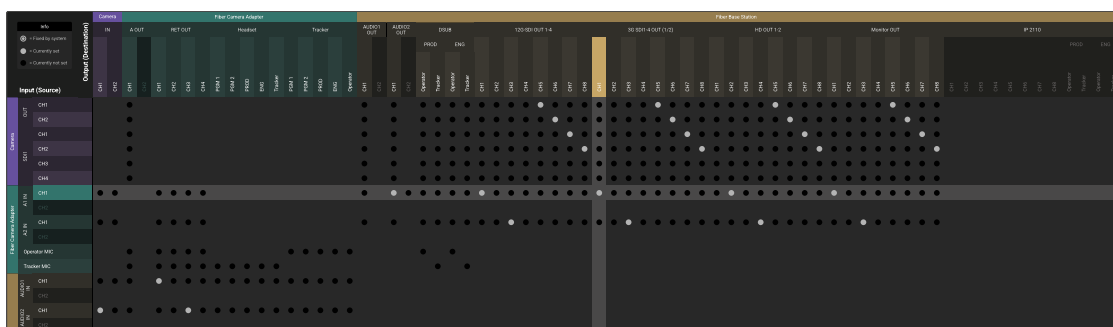

For example, the Audio Matrix allows for Fiber Camera Adaptor A1 IN CH1 to be routed to the Fiber Base Station AUDIO 1 out and also AUDIO 2 out.

5.6 Genlock

Connect the Genlock source to the Fiber Base Station FBS-1 through the REF IN connector. The signal is forwarded to the Fiber Camera Adapter FCA-1 through the fiber cable. The Fiber Camera Adapter FCA-1 forwards the signal to the camera through the Sync In connector of the camera. The system supports Tri-Level and Black Burst signals.

To configure Genlock for the system:

1. Connect the genlock source to the Fiber Base Station FBS-1.
2. Set the camera to synchronize to the Genlock signal.
3. Apply horizontal and vertical adjustment to the signal if needed.

Genlock Inputs and Outputs

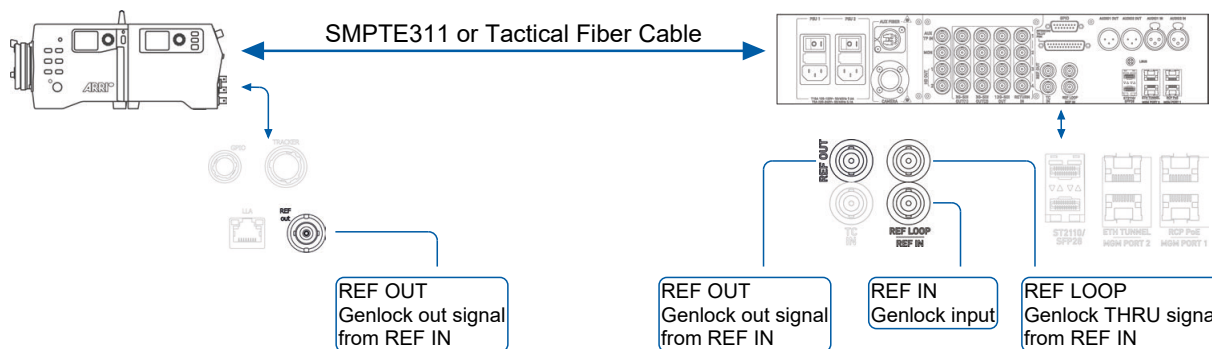

REF IN

Input for an analogue Genlock reference signal that can be Black Burst or Tri-level. The format detection is automatic.

REF OUT

Provides an active Genlock output. You can select the source in the LPS-1 web UI.

REF LOOP

Provides a loop through of the Genlock Signal as present at the REF IN Connector.

**NOTICE**

When daisy chaining the Reference signal to other equipment the last connection in the chain should be terminated with a 75 Ohm terminator.

Genlock Indication and Status

The Genlock format in use and the connection status is shown at different places in the system:

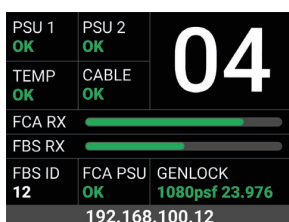

The HOME Screen of the Fiber Base Station FBS-1 shows the Genlock status. If the Fiber Base Station FBS-1 is synchronized to a Genlock signal the HOME screen shows the Genlock format in green color. If the Genlock signal is missing or if the format does not match, the entry reads "FAIL".

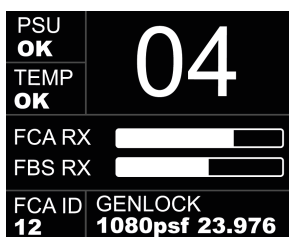

The HOME screen of the Fiber Camera Adapter FCA-1 shows that Genlock signal is correctly received. If the Genlock signal is missing the entry reads "FAIL".



Active synchronization is indicated by the Genlock icon on the HOME screen and in the Status Info of the camera. The icon turns orange when the camera cannot synchronize to the reference signal or when no signal is present. See *MENU > Alerts* for detailed information.

5.6.1 Genlock Fiber Base Station Settings**Genlock Configuration through the front panel FBS-1 Menu**

> Select *HOME > Genlock / Timecode* in the FBS-1 menu.

Please find the detailed menu structure in section "Genlock and Timecode Settings [▶ 48]".

Genlock Configuration through the LPS-1 Web UI

> Select *HOME > Genlock & Timecode* in the LPS-1 web UI.

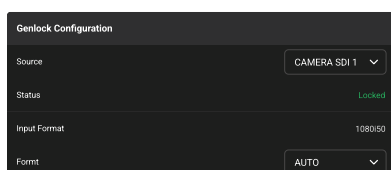
Genlock Configuration

You can set the genlock source in the Genlock Configuration area of the LPS-1 web UI. It shows the Genlock Status of the Fiber Base Station FBS-1.

Genlock Shift

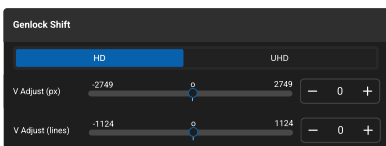

You can shift the signal horizontally and vertically to accurately synchronize the system to the Input Reference signal. It is recommended to use this control for video timing rather than use the Sync Shift control of the camera sensor menu.

5.6.2 Genlock Camera Settings

The camera can only synchronize to the Genlock signal when the camera's project and sensor frame rate match the frame rate of the Genlock signal.

➤ Select *MENU* > *System* > *Sensor* > *Genlock Sync*

Available options:

- Off* Synchronization is not active.
- Sync In* The camera synchronizes to a tri-level or black burst signal present at the SYNC IN connector.
- Timecode* The camera synchronizes to timecode present at the TC connector.

➤ Set Genlock Sync to Sync In.

Sync Shift

The Sync Shift setting applies an offset to the reference signal at the input. The minimum step size is 52 ns and the maximum correction is +/- 20 ms, depending on the sensor frame rate.

➤ Select *MENU* > *System* > *Sensor* > *Sync Shift* to adjust the sync shift.

Please note that whilst the camera has this Sync Shift adjustment, it is recommended to use the Video Timing adjustment in the LPS-1 web UI.

5.7 Timecode

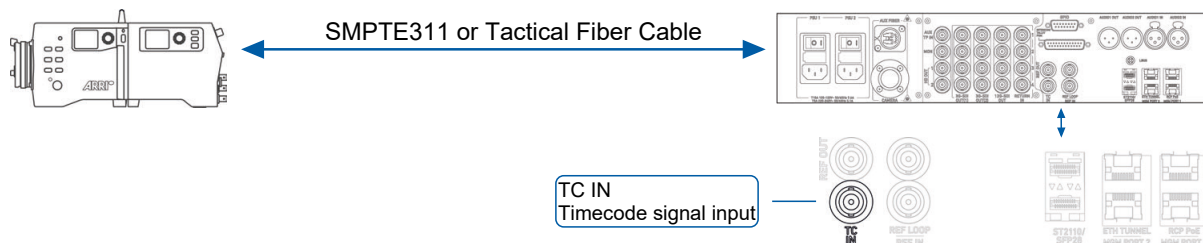

5.7.1 Timecode Base Station Settings

➤ Connect the timecode Source to the TC IN connector of the Fiber Base Station FBS-1.

Timecode Configuration through the front panel FBS-1 Menu

➤ Select *MENU* > *Genlock / Timecode* > *Timecode Source* on the FBS-1 menu.

Please find the detailed menu structure in section "Genlock and Timecode Settings [▶ 48]".

Timecode Configuration through the LPS-1 Web UI

➤ Select *HOME* > *Genlock & Timecode* in the LPS-1 web UI.

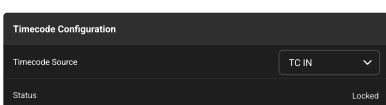

Timecode Configuration

You can set the timecode source in the Timecode Configuration area of the LPS-1 web UI. The area shows the Timecode Status of the Fiber Base Station FBS-1.

5.7.2 Timecode Camera Settings

➤ Select *HOME* > *TC* > *Options* > *Timecode Mode*.

Available options:

<i>Preset</i>	Synchronization is not active.
<i>Syn In</i>	The camera synchronizes to a tri-level or black burst signal present at the SYNC IN connector.
<i>Timecode</i>	The camera synchronizes to timecode present at the TC connector.

➤ Set Genlock Sync to *Syn In*.



NOTICE

Please note that the Time code format shall match the recording frame rate set in the camera.

5.8 Intercom

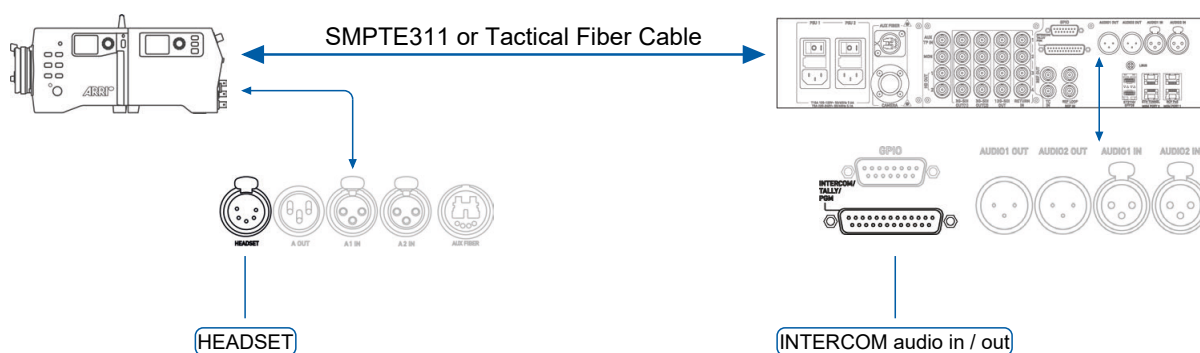

See "FBS-1 Rear Panel Overview [▶ 8]". The **Fiber Base Station FBS-1** has a D-Sub 25pin connector to connect an intercom system for both the PROD and ENG channel.

In appendix "Pin Outs Fiber Base Station FBS-1 [▶ 55]" the pin out of the D-Sub 25pin connector is shown.

See "FCA-1 Connector Bay Overview [▶ 15]". The **Fiber Camera Adapter FCA-1** has an XLR5F headset connector to connect a headset with dynamic or condenser microphone for intercom communication through the Production and Engineering channels or to monitor the program audio output.

In appendix "Pinouts Fiber Camera Adapter FCA-1 [▶ 57]" the pin out of the headphone connector is shown.

Intercom Configuration through the front panel FBS-1 Menu

➤ Select *HOME* > *Intercom* in the FBS-1 menu.

Please find the detailed menu structure in section "Intercom Settings [▶ 49]".

Intercom Configuration through the LPS-1 Web UI

➤ Select *HOME* > *Intercom* in the LPS-1 web UI.

Intercom Channel Configuration

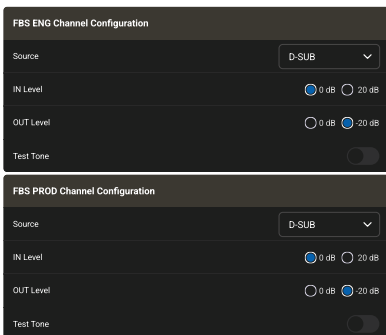

The FBS PROD Channel Configuration and FBS ENG Channel Configuration areas determine the

- Intercom signal source (D-SUB or IP),
- IN Level, and
- OUT Level

of the PROD / ENG channel.

You can activate a test tone for both intercom channels to check your signal paths.

PGM Channel Configuration



The FBS PPGM 1 / 2 Configuration areas determine the

- PGM 1 / 2 Level and
- PGM 1 / 2 IN Attenuation.

FCA Headset and FCA Tracker Configuration

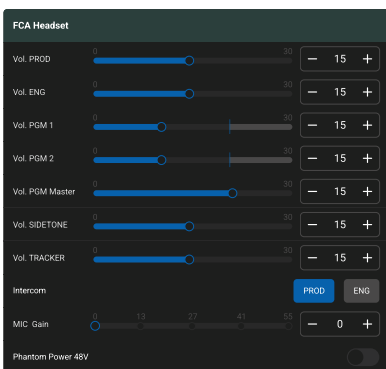

You can configure both the FCA Headset and the FCA Tracker in the FCA Headset and the FCA Tracker area.

The areas are similar, the adjacent illustration shows the upper part of the FCA Headset area.

5.9 GPI/O

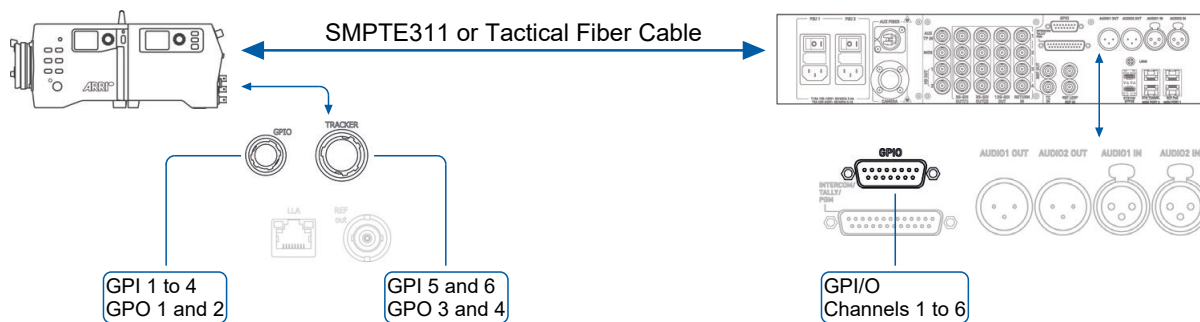

The LPS-1 system has six GPI channels and four GPO channels to control external devices.

See "FBS-1 Rear Panel Overview [▶ 8]". The **Fiber Base Station FBS-1** has a D-Sub 15pin connector that combines all GPI/O channels.

In appendix "Pin Outs Fiber Base Station FBS-1 [▶ 55]" the pin out of the D-Sub 15pin connector is shown.

See "FCA-1 Connector Bay Overview [▶ 15]". The **Fiber Camera Adapter FCA-1** has a GPI/O connector and a tracker connector. They combine the GPIO channels.

The GPI/O connector combines the GPI channels 1 to 4 and the GPO channels 1 and 2. The tracker connector combines the GPI channels 5 and 6 and the GPO channels 3 and 4.

In appendix "Pinouts Fiber Camera Adapter FCA-1 [▶ 57]" the pin out of the GPI/O and tracker connector.



NOTICE

GPI channel 3 is reserved for the CALL switch.

GPI/O Configuration through the front panel FBS-1 Menu

You can configure the GPI/O related features of the LPS-1 system through the LPS-1 web UI only.

GPI/O Configuration through the LPS-1 Web UI

➤ Select *HOME > GPI/O & Tally* in the LPS-1 web UI.

FBS GPO

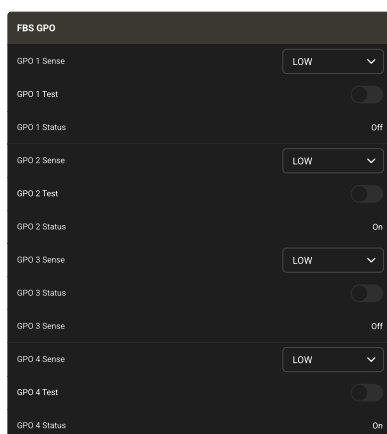

The FBS GPO area defines the Fiber Base Station FBS-1 GP Output channels 1 – 4. GP Output channels 5 and 6 are only available through IP2110. You can set the parameters:

- GPO Sense (HIGH or LOW),
- GPO Test (ON or OFF), and
- GPO Status (On or Off).

FBS GPI

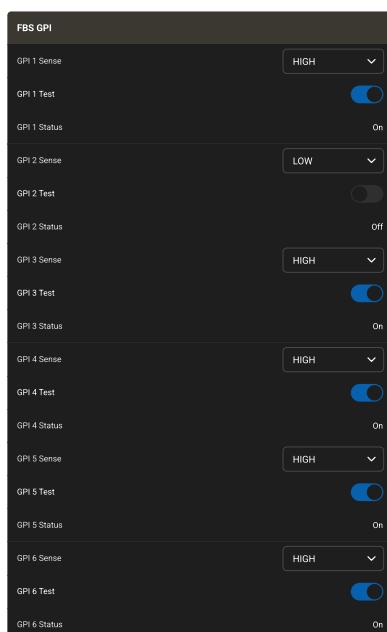

The FBS GPI area defines the Fiber Base Station FBS-1 GP Input channels 1 – 6. You can set the parameters:

- GPI Sense (HIGH or LOW),
- GPI Test (ON or OFF), and
- GPI Status (On or Off).

FCA GPO

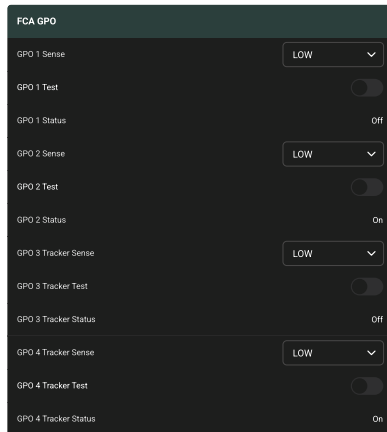

The FCA GPO area defines the Fiber Camera Adapter FCA-1 GP Output channels 1 and 2 and the Tracker GP Output channels 3 and 4. You can set the parameters:

- GPO Sense (HIGH or LOW),
- GPO Test (ON or OFF), and
- GPO Status (On or Off).

FCA GPI

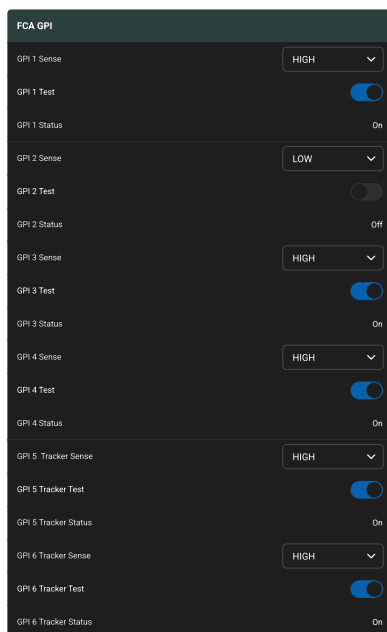

The FCA GPI area defines the Fiber Camera Adapter FCA-1 GP Input channels 1 – 4 and the Tracker GP Input channels 5 and 6. You can set the parameters:

- GPI Sense (HIGH or LOW),
- GPI Test (ON or OFF), and
- GPI Status (On or Off).

GPI/O Matrix

The GPI/O Matrix shows the routing of the GP inputs and GP outputs.

➤ Select *HOME* > *GPI/O Matrix* in the LPS-1 web UI to open the GPI/O Matrix.

Click on a *currently set* assignment to delete the assignment.

Click on a *currently not set* assignment to set the assignment.

Fixed by system assignments cannot be changed.

The illustration below shows the upper part of the matrix to increase readability for this manual.

Info		FCA				Fiber Base Station							
		Output (Destination)		Tracker		GPI/O		IP 2110					
Input (Source)		GPI/O	GPI/O	GPI/O	GPI/O	GPI/O	GPI/O	GPI/O	GPI/O	GPI/O	GPI/O	Call Out	Yellow Tally
Fiber Camera Adapter	Call												
	GPI 1												
	GPI 2												
	GPI 3												
	GPI 4												
	GPI 5												
RCP	Call												
	GPI 1												
	GPI 2												
S/P/I/O	GPI 3												

5.10 Tally

From SUP 1.4.1 the LPS-1 supports the TSL 3.1 and 5.0 protocol for Tally control from a video switcher or Tally controller through a network connection and uses the UDP protocol.

You can trigger preview (Green), On Air (Red) and Aux (yellow) Tally indicators through the protocol for status indication individually or at the same time. Additionally, you can assign the Tally indicators through the LPS-1 web UI to react to different Tally sources or control rooms in situations where there may be multiple directors for different video feeds.

The LPS-1 Web UI supports three control rooms.

TSL Tally Configuration

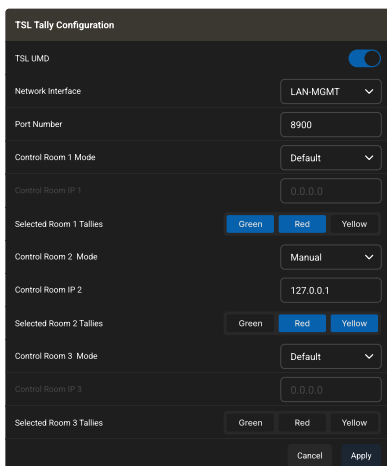

The Tally Configuration dialogue has the following options:

- TSL UMD: TSL Under Monitor Display activated / de-activated
- Network Interface: Port number
- Port Number: Port number
- Control Room [1..3] Mode: IP address of the related Control Room
- Control Room IP [1..3]: IP address of the related Control Room
- Selected Room [1..3] Tallies: Shows which Tallies are active (e.g. Green and Red Tally in Control Room 1 in the figure below).

TSL Tally Status

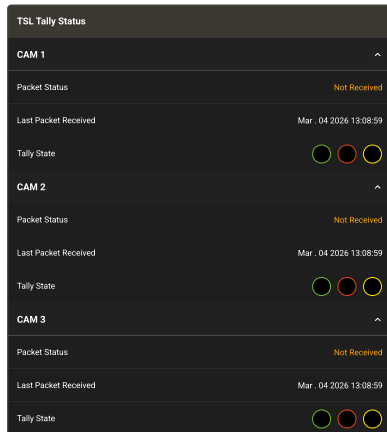

The Tally Status dialogue shows the following status messages:

CAM [1..3]	Close / expand status messages for camera 1 to 3.
Packet Status	Shows the packet status of the related camera.
Last Packet Received	Shows the date and time of the last correct packet received.
Tally State	Shows the Tally state for the related camera.

5.11 Lens User Buttons

The camera can give functions to ENG and box lens buttons.

➤ Select *MENU* > *User Buttons* > *Lens User Buttons*

Please find a complete overview and more information about the available user button functions in the ARRI ALEXA 35 user manual. It is available for download in the [ARRI Documentation Portal](#).

5.12 Fiber Base Station Status Area

The Status FBS area of the LPS-1 web UI shows the assignment and signal routing of the connections on the rear of the Fiber Base Station FBS-1.

Using the drop down arrow icon you can show/ hide the details of all areas for a better overview.

Video

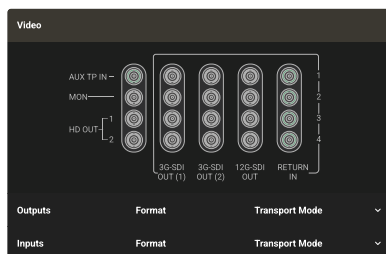

The video area shows the assignment of the video outputs and inputs, the detected format, and the transport mode. You can adjust the video setup in the Video and Video Matrix areas (see "Video [▶ 25]").

Audio

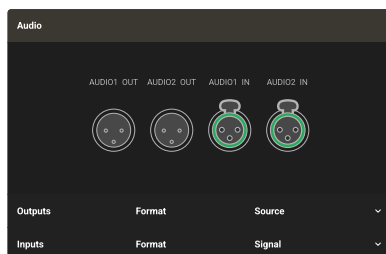

The audio area shows the assignment of the audio outputs and inputs, the detected format, and the signal source. You can adjust the audio setup in the Audio and Audio Matrix areas (see "Audio [▶ 30]").

Intercom Tally PGM

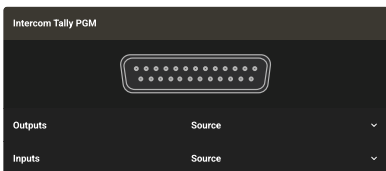

This area shows the assignment of the D-sub 25pin connector. You can adjust the corresponding settings in the Intercom (see "Intercom [▶ 35]") and GPI/O & Tally (see "GPI/O [▶ 36]") areas.

Genlock & Timecode

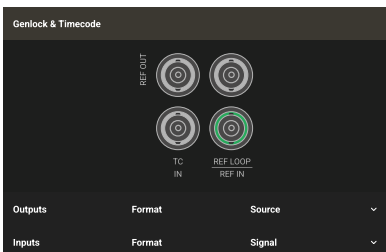

The Genlock & Timecode area contains all information about the system's Genlock & Timecode setup. You can adjust Genlock & Timecode in the Genlock (see "Genlock [▶ 32]") & Timecode (see "Timecode [▶ 34]") areas.

GPI/O

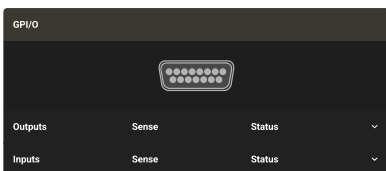

The GPI/O area shows the sense and status of the GP inputs and outputs. You can adjust the assignment and behavior of the GPI/O channels in the GPI/O & Tally area and the GPI/O matrix (see "GPI/O [▶ 36]").

Ethernet

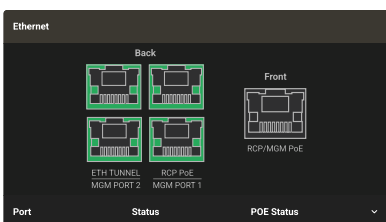

The Ethernet section shows the status and PoE status of the Fiber Base Station FBS-1 network connections.

Camera Cable Status

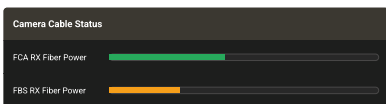

Shows the signal quality and possible issues of the fiber optic cable. For quick assessment, the status is indicated by three colors:

- Green: Signal quality OK
- Yellow: Signal quality sufficient
- Red: Signal quality poor (when indicating a minimum system instability may occur.)

Please see the "Diagnostics [▶ 43]" page of the LPS-1 web UI for more detail on the status.

Power Supply Status



Shows the status of the two Power Supply Units of the Fiber Base Station FBS-1.

5.13 Fiber Camera Adapter Status Area

The Status FCA area of the LPS-1 web UI shows the assignment and signal routing of the connections on the rear of the Fiber Camera Adapter FCA-1.

You can hide the details of all areas for a better overview.

Video

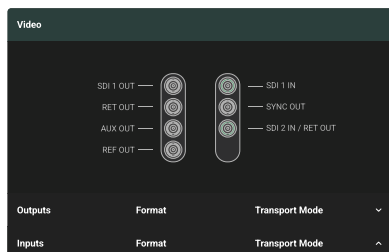

The video area shows the assignment of the video outputs and inputs, the detected format, and the transport mode. You can adjust the video setup in the Video and Video Matrix areas (see "Video [▶ 25]").

Audio

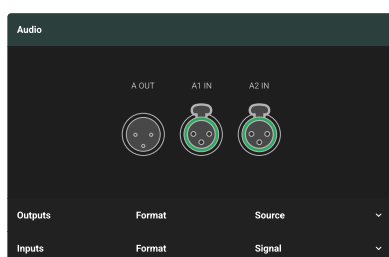

The audio area shows the assignment of the audio outputs and inputs, the detected format, and the signal source. You can adjust the audio setup in the Audio and Audio Matrix sections (see "Audio [▶ 30]").

Tracker

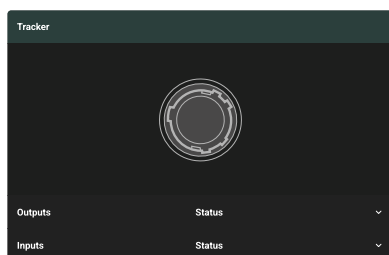

This area shows the assignment of the tracker connector. You can adjust the corresponding settings in the Intercom and GPI/O & Tally areas (see "GPI/O [▶ 36]").

GPI/O

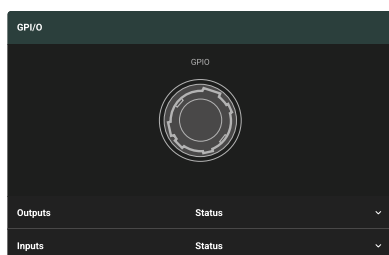

The GPI/O area shows the sense and status of the GP inputs and outputs. You can adjust the assignment and behavior of the GPI/O channels in the GPI/O & Tally area and the GPI/O Matrix (see "GPI/O [▶ 36]").

Ethernet

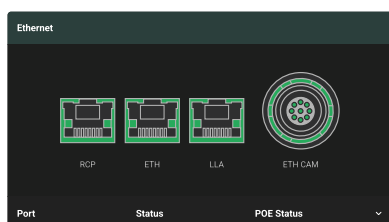

The Ethernet area shows the status and PoE status of the Fiber Camera Adapter FCA-1 network connections.

Power Supply Status

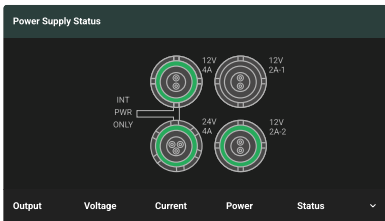

Shows the status of the power outputs of the Fiber Camera Adapter FCA-1.

Camera Cable Status



Shows the signal quality and possible issues of the fiber optic cable. For quick assessment, the status is indicated by three colors:

- Green: Signal quality OK
- Yellow: Signal quality sufficient
- Red: Signal quality poor (when indicating a minimum system instability may occur.)

Please see the "Diagnostics [▶ 43]" of the LPS-1 web UI for more detail on the status.

5.14 Diagnostics, Settings and Alerts

Diagnostics

The Diagnostics area of the LPS-1 web UI contains several subgroups with data, sensor values, and status messages for information and diagnostics.

Areas related to the Fiber Base Station FBS-1:

FBS Info	FBS Voltage sensors	FBS logfiles
FBS Fan	FBS Temperature Sensors	FBS Current Sensors
FBS Optical RX Module Status		

Areas related to the Fiber Camera Adapter FCA-1:

FCA Info	FCA Voltage sensors	FCA logfiles
FCA Fan	FCA Temperature Sensors	FCA Miscellaneous Status
FCCA Optical RX Module Status		

Settings

The settings area of the LPS-1 web UI contains global system features.

Firmware Updater

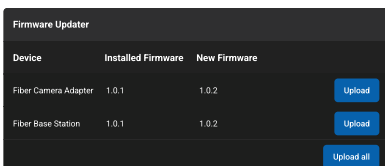

The Firmware Updater area shows information about the installed and new available firmware versions. Use the *UPLOAD* buttons to install new firmware both on the Fiber Camera Adapter FCA-1 and / or the Fiber Base Station FBS-1.

Presets

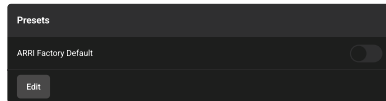

You can save and activate presets in the Preset area. This allows multiple configurations to be saved and recalled for each project the system may be employed upon. If you get lost or get the system back from a production, it is a good idea to activate the *Factory Default* preset.

Reboot FCA & Camera



➤ Push the *Reboot FCA & Camera...* button to reboot the Fiber Camera Adapter FCA-1 and the camera.

Reboot FCA & FBS



➤ Push the *Reboot FCA & FBS...* button to reboot the Fiber Camera Adapter FCA-1 and the Fiber Base Station FBS-1.

Factory Reset



➤ Push the *Factory Reset* button to perform a factory reset of the system. All settings are reset to factory defaults.

System Date and Time

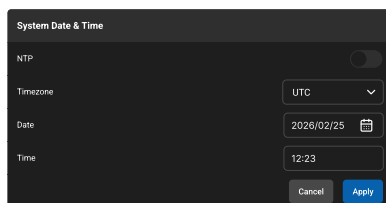

Use the System Date and Time area to set the date and time related features.

Stealth Mode

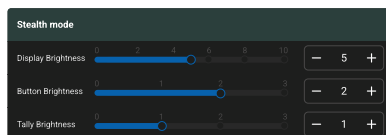

The Stealth Mode area defines the brightness of the displays, buttons and the Tally indicators. Use the stealth mode to prevent stray light irritation during a production.

Alerts

Alerts and notifications tell the user about not normal system behavior. If an alert or notification shows up, open the notification page to get more information. Camera service might need the information given in the notification list.



If an alert is activated, the system shows a red field with a short description of the alert. Push the Settings button to open the alerts area.

The Alerts area shows a list of all alerts and notifications and the status of each alert / notification. Push the *Go to Issue* button to get more information about the issue.

ID	DateTime	Category	Description	Severity	Status	
fbs_psu1_error	18/02/2026, 15:09:17	CanPowerManager	PSU 1 Error 240 N/A	Error	Solved	Go to Issue
fbs_psu1_version	18/02/2026, 15:09:18	SystemManager	PSU 1 1.0.6 PSU 2.1.0.4	Error	Active	

6 Remote Control

6.1 LPS-1 Web UI

The LPS-1 web UI gives full configuration of the Fiber Camera Adapter FCA-1 and Fiber Base Station FBS-1, including signal routing, diagnostics, and software updates.

Additionally, you can open the ARRI ALEXA 35 web remote page through the LPS-1 web UI for configuration of the camera. Wherever applicable, the LPS-1 web UI menu paths and options are mentioned in this manual.

6.2 SKAARHOJ Web Interface

The SKAARHOJ web interface is a powerful control application with a comprehensive set of features and options. Please find the online manual for the web interface here: [Reactor - The manual](#)

6.3 Web Remote

You can control the camera remotely using the camera's Web Remote feature accessed through the LPS-1 web UI or with a direct Ethernet or WiFi connection.

The connection to the camera web remote is set up automatically by the LPS-1 system. To set up a WiFi or Ethernet connection where direct communication is needed to the camera from different platforms please follow the instructions below.

- Connect the camera to a computer through WiFi or Ethernet.
- Open a web browser and enter the URL `http://localALEXA35-xxxxx.local` (replace xxxxx with the camera's 5-digit serial number).

To access the Web Remote through this URL, the device shall support zero-configuration networking (zeroconf), such as Apple Bonjour. If zeroconf is not available, the Web Remote can be accessed through the network's IP address (WiFi or LAN IP). The WiFi IP is set to 192.168.153.1 by default. You can assign the LAN IP by a DHCP server or configured manually. To check the LAN IP, navigate to *MENU > Info > Network Info*, or view the Info page on the side display.

WiFi is active per factory default, If WiFi is not active, activate WiFi through the MVF-2 in *MENU > System > Network / WiFi > WiFi Power*. If no MVF-2 is connected, push the FUNCTION button FN and camera button 6 to activate WiFi.

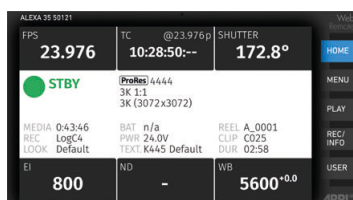

HOME

Shows the camera HOME screen (as on MVF-2) with access to the main parameters.

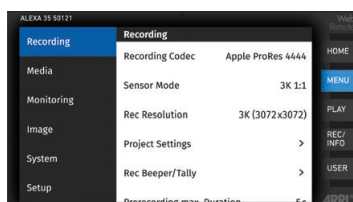

MENU

Access to the camera menu.

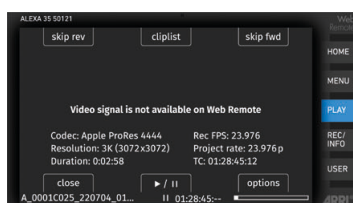

PLAY

Starts playback from the recording medium. Provides the same controls as the MVF-2 but does not show a video signal.

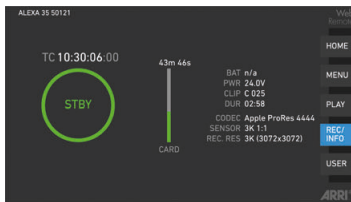

REC / INFO

Contains information on the main recording parameters, plus a *REC* button. Click the big circle icon to start / stop recording.

Rec status and timecode may respond slightly delayed depending on the network's speed.

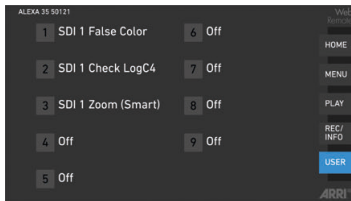

USER

Shows configuration of the camera user buttons and allows you to trigger them. Push the number icons to trigger the user buttons.



NOTICE

Frequent reloading of the Web Remote camera interface connected with WiFi indicates a limited WiFi range. Please place the device closer to the camera or connect via Ethernet. You may also consider using the WiFi client mode which allows connecting the camera to a WiFi network.

After a camera update, the Web Remote feature may not be fully functional until the browser cache of your web browser has been cleared. Always use a 'private' or 'incognito' browser window when using the Web Remote to operate the camera and to perform a SUP update. This prevents possible erratic behavior.

7 Settings

7.1 Network Settings

Setting	Description	Default	Where?
<i>Camera Channel Number</i>	Set the camera channel number.	<i>01</i>	Web, FBS
<i>IP Mode</i>	Set the IP mode for the Fiber Base Station between <i>Static</i> and <i>DHCP</i> .	<i>Static</i>	Web, FBS
<i>FBS IP Address</i>	Set the IP address for the Fiber Base Station.		Web, FBS
<i>Subnet Mask</i>	Set the subnet mask.		Web, FBS
<i>Gateway</i>	Set the gateway.		Web, FBS
<i>DNS Server</i>	Set the IP address of the DNS server.		Web, FBS
<i>Domain Name</i>	Set the Domain Name of the network.		Web, FBS
<i>MAC Address</i>	Enter the MAC address of the Fiber Base Station.		Web
<i>Camera CAP Server Password</i>	Enter the CAP Server Password of the camera connected to the Fiber Base Station.	<i>arri</i>	Web

The sub menu items *FBS IP*, *SUBNET*, *GATEWAY* are grayed out when *IP Mode* is set to *DHCP*.

7.2 Audio Settings

Routing of audio signals is not included in the table below, as this is done through the Audio Matrix in the LPS-1 Web UI.

Setting	Description	Default	Where?
<i>AUDIO 1 / 2 IN Format</i>	Set the format on the AUDIO 1 / 2 IN connector of the Fiber Base Station between <i>LINE</i> and <i>AES</i> .	<i>LINE</i>	Web, FBS
<i>AUDIO 1 / 2 IN Gain</i>	Set the gain on the AUDIO 1 / 2 IN connector of the Fiber Base Station between <i>0</i> and <i>30 dB</i> .	<i>0 dB</i>	Web, FBS
<i>AUDIO 1 / 2 OUT Format</i>	Set the format on the AUDIO 1 / 2 OUT connector of the Fiber Base Station between <i>LINE</i> and <i>AES</i> .	<i>LINE</i>	Web, FBS
<i>AUDIO 1 / 2 OUT SOURCE CH1</i>	Set the AUDIO 1 / 2 OUT source for channel 1		Web, FBS
<i>AUDIO 1 / 2 OUT SOURCE CH2</i>	Set the AUDIO 1 / 2 OUT source for channel 2		Web, FBS
<i>AUDIO 1 / 2 OUT TEST TONE 1KHz</i>	Activate / de-activate a test tone to be output on the AUDIO 1 OUT connector.	<i>OFF</i>	Web, FBS
<i>A1 / A2 IN Format</i>	Set the format on the A1 / A2 IN connector of the Fiber Camera Adapter: <i>MIC +48 V / MIC / LINE / AES</i>		Web, FCA
<i>A1 / A2 IN Gain Control</i>	Set the gain control for the A1 / A2 IN connector of the Fiber Camera Adapter between <i>Manual</i> and <i>Auto</i> .	<i>Manual</i>	Web, FCA
<i>A1 / A2 IN Gain</i>	Set the gain on the A1 / A2 IN connector of the Fiber Camera Adapter between <i>0</i> and <i>30 dB</i> .	<i>0 dB</i>	Web, FCA
<i>A1 / A2 IN Test Tone</i>	Activate / de-activate a test tone on the A1 / A2 IN connector of the Fiber Camera Adapter.	<i>off</i>	Web, FCA
<i>A OUT Format</i>	Set the format on the A OUT connector of the Fiber Camera Adapter between <i>LINE</i> and <i>AES</i> .	<i>LINE</i>	Web, FCA
<i>A OUT Test Tone</i>	Activate / de-activate a test tone to be output on the A OUT connector of the Fiber Camera Adapter.	<i>off</i>	Web, FCA

7.3 Video Settings

Routing of video signals is not included in the table below, as this is done through the Video Matrix in the LPS-1 web UI.

Setting	Description	Default	Where?
<i>MON > STATUS DISPLAY</i>	Activate / De-activate the status display on the MON output of the Fiber Base Station.	<i>On</i>	Web, FBS
<i>MON > FONT COLOR</i>	Set the font color of the status display on the MON output (red, green, blue, white, black).	<i>white</i>	Web, FBS
<i>MON > STATUS COMPONENTS</i>	Select the status components to be shown in the status display on the MON output.	<i>all enabled</i>	Web, FBS
<i>3G-SDI OUT 1 / 2 Source</i>	Set the source for the 3G-SDI OUT 1 / 2 outputs 1-4 of the Fiber Base Station: <i>Camera SDI 1</i> <i>Camera SDI 2</i> <i>Color Bars</i>	<i>Camera SDI 1</i>	Web, FBS
<i>12G-SDI OUT 1/2 or 3/4</i>	Set the source for the 12G-SDI OUT outputs 1 / 2 or 3 / 4 of the Fiber Base Station: <i>Camera SDI 1</i> <i>Camera SDI 2</i> <i>Color Bars</i>	<i>Camera SDI 1</i>	Web, FBS
<i>DOWNCONVERTER > HD OUT 1 / 2 Source</i>	Set the source for the HD OUT 1 / 2 output of the Fiber Base Station: <i>Camera SDI 1</i> <i>Camera SDI 2</i> <i>Color Bars</i>	<i>Camera SDI 1</i>	Web, FBS
<i>DOWNCONVERTER > HD OUT 1 / 2 Format</i>	Set the output format for the HD OUT 1 / 2 output of the Fiber Base Station: <i>1.5G (p)</i> <i>1.5G (psf)</i> <i>1.5G (i)</i> <i>3G Level A</i> <i>3G Level B</i>	<i>1.5G (p)</i>	Web, FBS
<i>DOWNCONVERTER > HD OUT 1 / 2 H Adjust</i>	Apply a horizontal shift (pixel) to the HD OUT 1 / 2 output of the Fiber Base Station.	<i>0</i>	Web, FBS
<i>DOWNCONVERTER > HD OUT 1 / 2 V Adjust</i>	Apply a vertical shift (lines) to the HD OUT 1 / 2 output of the Fiber Base Station.	<i>0</i>	Web, FBS
<i>AUX TP IN Source</i>	Set the source for AUX TP IN: BNC: The AUX TP IN BNC connector is used as the source. IP: Ethernet is used as the source.	<i>BNC</i>	Web, FBS
<i>RETURN IN > RETURN 1 / 2 / 3 / 4 SOURCE</i>	Set the source for Return 1 / 2 / 3 / 4: BNC: The RETURN IN 1 BNC connector is used as the source. IP: IP is used as the source.	<i>BNC</i>	Web, FBS

7.4 Genlock and Timecode Settings

Setting	Description	Default	Where?
<i>Genlock Source</i>	Set the Genlock source: <i>REF IN</i> : The REF IN BNC connector of the Fiber Base Station is used as the source. <i>IP</i> : IP is used as the source.	<i>REF IN</i>	Web, FBS
<i>Genlock Format</i>	Set the Genlock format.		Web, FBS
<i>Genlock H Adjust</i>	Apply a horizontal shift (pixel) to genlock signal.	<i>0</i>	Web, FBS
<i>Genlock V Adjust</i>	Apply a vertical shift (pixel) to the genlock signal.	<i>0</i>	Web, FBS

Setting	Description	Default	Where?
<i>Timecode Source</i>	Set the timecode source: <i>TC IN</i> : The TC IN BNC connector of the Fiber Base Station is used as the source. <i>IP</i> : Ethernet is used as the source.	<i>TC IN</i>	Web, FBS

7.5 Intercom Settings

Setting	Description	Default	Where?
<i>PROD / ENG Source</i>	Set the source for the PROD / ENG channel: <i>D-SUB</i> : The INTERCOM/TALLY/PGM connector of the FBS-1 is used as the source. <i>IP</i> : IP is used as the source.	<i>D-SUB</i>	Web, FBS
<i>PROD / ENG Input Level</i>	Set input level for the PROD / ENG channel (0 dB to -9 dB).	<i>0 dB</i>	Web, FBS
<i>PROD / ENG Gain</i>	Set gain for the PROD / ENG channel (0 dB to 30 dB).	<i>0 dB</i>	Web, FBS
<i>PROD / ENG Test Tone</i>	(De-)Activate a test tone to be output on the PROD / ENG channel.	<i>off</i>	Web, FBS
<i>PGM 1 / 2 Input Level</i>	Set input level for the PGM 1 / 2 channel (0 dB to -9 dB).	<i>0 dB</i>	Web, FBS
<i>PGM 1 / 2 Gain</i>	Set gain for the PGM 1 / 2 channel (0 dB to 30 dB).	<i>0 dB</i>	Web, FBS
<i>Headset Mic Phantom 48V</i>	(De-)Activate +48 V phantom power on the HEADSET connector of the FCA-1.	<i>off</i>	Web, FCA
<i>Headset Mic Gain</i>	Set gain for headset microphone (-64 dB to -10 dB).		Web, FCA
<i>Headset Sidetone PROD / ENG</i>	(De-)Activate PROD / ENG sidetone on headset.		Web, FCA
<i>Headset Routing PROD / ENG / PGM 1 / PGM 2</i>	Set the headset routing for the channel: <i>Off</i> : The channel is not output on the headset. <i>Left</i> : The channel is output on the left ear. <i>Right</i> : The channel is output on the right ear. <i>Left + Right</i> : The channel is output on both ears.		Web, FCA
<i>Headset Test Tone</i>	(De-)Activate a test tone on the headset.	<i>off</i>	Web, FCA
<i>Tracker Mic Phantom 48V</i>	(De-)Activate phantom +48 V power on the TRACKER connector of the FCA-1.	<i>off</i>	Web, FCA
<i>Tracker Mic Gain</i>	Set gain for the tracker microphone (-64 dB to -10 dB).		Web, FCA
<i>Tracker Sidetone PROD / ENG</i>	(De-)Activate PROD / ENG sidetone on tracker.	<i>off</i>	Web, FCA
<i>Tracker Routing PROD / ENG / PGM 1 / PGM 2</i>	Set the tracker routing for the channel: <i>Off</i> : The channel is not output on the tracker. <i>Left</i> : The channel is output on the left ear. <i>Right</i> : The channel is output on the right ear. <i>Left + Right</i> : The channel is output on both ears.		Web, FCA
<i>Tracker Test Tone</i>	(De-)Activate a test tone on tracker.	<i>off</i>	Web, FCA

8 Tally Light Module TLM-1

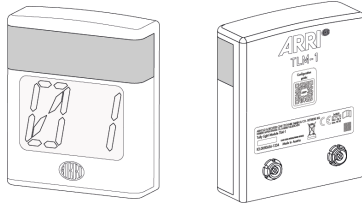

The Tally Light Module TLM-1 has a 16-segment, alphanumeric camera ID display and a versatile mounting interface. It connects to the camera through an LBUS cable.

Installation

- Use the RIA-1 Bracket (K2.0039465) to attach the TLM-1 to the camera handle.
- Connect the TLM-1 to the camera with an LBUS cable. You can connect the TLM-1 at any point in the LBUS chain or directly to the LBUS connector on the front of the camera or the LBUS connector on the lens mount (if applicable), because LBUS devices support daisy-chaining.

Operation

The camera menu has a setting to specify the behavior of all connected tally lights. This includes the tally on the MVF-2, the Tally Light Module TLM-1, and the built-in tally of a box lens. Through this setting, you can

- de-activate tally functionality,
- respond to the camera's internal recording state, or
- react to a remote control signal.

Select *MENU > System > Buttons + Display > Tally* and set to *On (Remote/CAP)*.

Brightness Control

You can adjust the brightness of both the tally light and the camera ID display in the camera menu.

- Select *MENU > System > Buttons + Display > Tally Brightness* to adjust the brightness of the tally.
- Select *MENU > System > Buttons + Display > Tally ID Brightness* to adjust the brightness of the camera ID display.

9 Large Lens Adapter LLA-1

You can attach a large box lens to an ARRI camera quickly and seamlessly with the Large Lens Adapter LLA-1. It is lightweight and robust. It offers different mounting options for accessories and cable management. It is compatible with all PL and B4 box lenses. The Large Lens Adapter LLA-1 is shipped with a cable for connecting a box lens to a PL mount (Hirose), a rain cover and a flight case.

Please find detailed installation instructions in the LPS-1 operating manual. The operating manual is available for free download at the [ARRI documentation portal](#).

9.1 Large Lens Adapter Control Module

The Large Lens Adapter LLA-1 Control Module is part of the ARRI Live Production System LPS-1. It is attached to the Large Lens Adapter LLA-1. It connects a box lens with a Centronics 36pin connector to the camera. The Control Module allows control of focus, zoom, and iris through the camera or connected accessories.

The Control Module converts the Centronics interface of the box lens to LBUS and Hirose. The Control Module itself connects to the camera through LBUS or, when you use a compatible mount, through Hirose. The lens is integrated seamless into the system. Make sure that the camera body, lens, and Control Module are all updated to the latest firmware versions to make sure full compatibility.

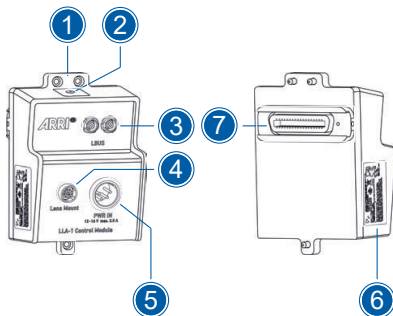

- 1 M4 Mounting Holes
- 2 Setup Button
- 3 LBUS Connectors
- 4 Lens Mount Connector
- 5 PWR IN Connector (XLR4M)
- 6 Product Label
- 7 Centronics Connector

Setup Button

The connection type is determined by the cable used, either a Hirose connection or an LBUS connection. The setup button allows you to manually select the appropriate cable type (Hirose or LBUS) to ensure the correct configuration, as this is not automatically detected. The background illumination of the button indicates the selected mode:

Green (solid)	LBUS connection is in use and communication is established (ready for operation).
Blue (solid)	Hirose connection is in use and communication is established (ready for operation).
Green (flashing)	No communication with the lens.
Red (flashing)	Power supply is insufficient.
Green/Blue (flashing)	LBUS standalone control (No connection to the camera).
Green/Red (flashing)	No data available from LBUS or Hirose.
Blue (flashing)	Device executes the bootloader (device update).

➤ Push the *SETUP* button to toggle the connection type between LBUS and Hirose.

LBUS

You can daisy chain LBUS compatible devices of the ARRI ECS Electronic Control System (e.g. lens motors). They are supplied by the camera with regulated 24.0 V DC (maximum current 4.0 A). When you use the camera with the PL Mount (LBUS), you can connect the Control Module and the camera through one of the LBUS connectors on the Control Module.

Lens Mount Connector (Hirose)

Hirose connectors are widely used in the broadcast industry for power and data transmission in professional camera systems. When you use the camera with the PL Mount (Hirose), you can connect the Control Module and the camera through the Hirose connector on the Control Module.

PWR IN (XLR4M)

The XLR4M Power IN plug supplies DC power to high-power lenses (nominal current 2.0 A) through the Hirose interface. It ensures a stable and reliable connection for powering lenses from external power sources.

Centronics Connector

Box lenses, commonly used in broadcast and live production, are high-performance zoom lenses designed for long-range and precision shooting. These lenses are typically equipped with a standard Centronics 36pin connector, which facilitates communication and power transmission between the lens and the camera system. The box lens connects directly to the Control Module, with the Centronics connector on the lens docking into the Centronics socket on the Control Module.

Please find detailed installation instructions in the LPS-1 operating manual. The operating manual is available for free download at the [ARRI documentation portal](#).

10 Appendix

10.1 Technical Data

10.1.1 Fiber Base Station FBS-1

Video Outputs	2x Quad Link 3G or 8x Single Link 3G SDI (BNC) 4x Single Link 12G, Single Link 6G, Single Link 3G or 2x Dual Link 6G SDI (BNC) 2x 1.5G SDI (down converted to HD) (BNC) 1x Monitor Out (HD, with optional Status Overlay) (BNC)
Video Inputs	4x 3G Return Video In (BNC) 1x 12G AUX/TP SDI In (BNC)
Audio Outputs	2x Line / AES (XLR) Embedded Audio on all SDI Out (BNC)
Audio Inputs	2x Line / AES (XLR)
Genlock	1x REF IN (Black Burst / Tri-Level) (BNC) 1x REF OUT (BNC) 1x REF Loop (passive loop out) (BNC)
SMPTE Fiber	3K Series LEMO Connector (max. Cable Length 2 km)
Additional Interfaces	1x Fiber Tunnel (Neutrik Opticon, 2x Fiber 1550 nm) 2x SMPTE 2110/2022-7 (ST2110 with Redundancy) (SFP28) 1x Timecode In (BNC) 1x RCP PoE (RJ45) 2x MGMT (Diagnostics, Configuration and Update) (RJ45) 1x RCP/MGM PoE (RJ45, Front side) 1x Ethernet Tunnel 1Gbps (RJ45) 4x GPIO Inputs / Outputs (15W-D) 1x Intercom / Tally / PGM (Program / Engineering, Tally, 2x Program Audio) (25W-D)
Mains Input (PSU 1 & 2)	100 - 120 V~ 50/60 Hz, 7.6 A 200 - 240 V ~ 50/60 Hz, 3.1 A
Mains Power Cable Specification Japan	Mains plug and connectors shall be according to JIS C 8283-1 and JIS C 8286.
Fuse type of the power supply units PSU 1 & 2	100 – 120 V mains voltage: 250 V-rated, T 10A (slow-blow) 20 mm cartridge-type UL certified fuse (T10A 250V H) 200 – 240 V mains voltage: 250 V-rated, T 5A (slow-blow) 20 mm cartridge-type UL certified fuse (T5A 250V H)
Available Power for Camera Head	400 W
Dimensions (W x H x L)	89 x 438 x 532 mm / 3.5 x 17.2 x 20.9"
Weight	12.6 kg / 27.8 lbs

All specifications are typical values. Subject to change without notice.

10.1.2 Fiber Camera Adapter FCA-1

Video Outputs	1x 12G, 3G or 1.5G Camera SDI 1 Out (BNC) 1x 3G or 1.5G Return Video SDI Out (BNC) 1x 12G, 3G or 1.5G AUX / Teleprompt Out (BNC)
Video Inputs	2x 12G, 3G or 1.5G SDI (BNC)
Audio Outputs	1x Line / AES (XLR) Embedded Audio on all SDI Outputs
Audio Inputs	2x Line / AES (XLR)
Genlock	1x REF OUT (Black Burst / Tri-Level) (BNC)
SMPTE Fiber	3K Series LEMO Connector (max. Cable Length 2 km)
Additional Interfaces	1x AUX Fiber (Neutrik Opticon) 1x RCP PoE for Local Camera Control (RJ45) 1x LLA PoE for Large Lens Adapter Control (RJ45) 1x Ethernet Tunnel 1Gbps (RJ45) 1x Operator Headset (XLR) 1x GPIO (Hirose) 1x Tracker (Hirose)
Power Outputs	2x 12 V, 2 A (LEMO) 1x 12 V, 4 A (LEMO) 1x 24 V, 4 A (LEMO)
Dimensions (H x W x L)	148 x 180 x 210 mm / 5.82 x 7.09 x 8.27"
Weight	3.36 kg / 7.4 lbs (without ALEXA 35) ~6.36 kg / 14 lbs (with ALEXA 35, without lens)

All specifications are typical values. Subject to change without notice.

10.1.3 Tally Light Module TLM-1

Interfaces	2x LBUS (LEMO 4pin) for lens motors, daisy chainable; supports LBUS protocol, LCS protocol (for ALEXA cameras) and EXT protocol (for AMIRA cameras) Mounting points for accessories
External Power Supply	10.5 - 34 V DC
Power Consumption (typ)	6 W
Dimensions (HxWxT)	99 x 33,3 x 84 mm / 3.9 x 1.3 x 3.3"
Weight	0,36 kg / 0.79 lbs

All specifications are typical values. Subject to change without notice.

10.1.4 Large Lens Adapter Control Module

Large Lens Connector	Centronics 36pin
Lens Mount Connector (Camera)	LBUS / Hirose 12pin
Power In Connector	XLR 4pin
Power Supply LBUS	10.5 - 34 V DC / 100 W
Power Supply for Lens	12 V - 16 V DC / 40 W
Dimensions (H x W x L)	125,3 x 80,9 x 61,3 mm / 125,3 x 80,9 x 61,3 mm
Weight	0,45 kg / 0,992 lbs

All specifications are typical values. Subject to change without notice.

10.2 Pinouts

Pinouts Fiber Base Station FBS-1



Fiber Connector

Lemo 3K SMPTE 311M

Pin 1	Fiber A (SM17) yellow
Pin 2	Fiber B (SM17) blue
Pin 3	Control + (C02E) red
Pin 4	Control – (C02E) clear
Pin 5	Power – (P03EA) black
Pin 6	Power + (P03EA) white

Pin orientation as seen by the user.

BNC Sockets 75 Ohm

MON
12G-SDI OUT 1 - 4

HD OUT 1 / 2
RETURN IN 1 - 4

3G-SDI OUT 1 / 2

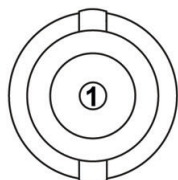

BNC

Pin 1 Serial Digital Video 75 Ohm

BNC Sockets 10 kOhm

REF OUT

REF IN

REF LOOP

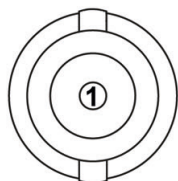

BNC

Pin 1 Genlock I/P Video Signal 10kOhm

TC IN

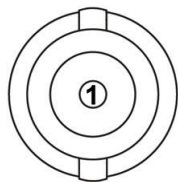

BNC

Pin 1 Timecode I/O Signal I/P 10K / O/P 100R

GPIO (D-Sub 15pin)

D-Sub 15pin socket

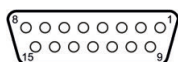

Pins 1 - 4	GPI 1 – GPI 4	Pin 10	GPO 2 (+)
Pin 5	n.c. / GPI 5	Pin 11	GPO 2 (-)
Pin 6	n.c. / GPI 6	Pin 12	GPO 3 (+)
Pin 7	GPO 1 (+)	Pin 13	GPO 3 (-)
Pin 8	GPO 1 (-)	Pin 14	GPO 4 (+)
Pin 9	GND	Pin 15	GPO 4 (-)

Pin orientation as seen by the user.

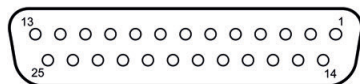
Intercom / Tally / PGM (D-Sub 25pin)

Pin	Signal	Level	Direction	Description
Pin 1	ENG (R) (X) Out	0 dBu	Out	Intercom Out balanced
Pin 2	ENG (R) (Y) Out	0 dBu	Out	Intercom Out balanced
Pin 3	ENG (G)	-	GND	GND Intercom ENG
Pin 4	ENG (T) (X) In	0 dBu	In	Intercom In balanced
Pin 5	ENG (T) (Y) In	0 dBu	In	Intercom In balanced
Pin 6	PGM1 (X) In	0 / -20 dBu	In	PGM1 In balanced
Pin 7	PGM1 (Y) In	0 / -20 dBu	In	PGM1 In balanced
Pin 8	PGM1 (G)	-	GND	GND for PGM1
Pin 9	GND	-	GND	GND for AUX
Pin 10	n.c.	-	-	-
Pin 11	R TALLY (X) In	24 V DC On	-	Red tally, short pins to activate
Pin 12	R TALLY (Y) In	0 V Off	-	Red tally, short pins to activate
Pin 13	GND	-	GND	Chassis GND
Pin 14	PROD (R) (X) Out	0 dBu	Out	Intercom Out balanced
Pin 15	PROD (R) (Y) Out	0 dBu	Out	Intercom Out balanced
Pin 16	PROD (G)	-	GND	GND for Intercom PROD
Pin 17	PROD (T) (X) In	0 dBu	In	Intercom In balanced
Pin 18	PROD (T) (Y) In	0 dBu	In	Intercom In balanced
Pin 19	PGM2 (X) In	0 / -20 dBu	In	PGM2 In balanced
Pin 20	PGM2 (Y) In	0 / -20 dBu	In	PGM2 In balanced
Pin 21	PGM2 (G)	-	GND	GND for PGM2
Pin 22	n.c.	-	-	-
Pin 23	n.c.	-	-	-
Pin 24	G TALLY (X) In	24 V DC On	-	Green tally, short pins to activate
Pin 25	G TALLY (Y) In	0 C Off	-	Green tally, short pins to activate

Pin orientation as seen by the user.

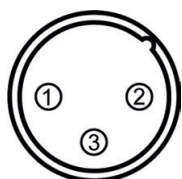
AUDIO 1 / 2 OUT

XLR3M plug

Pin 1	Shield
Pin 2	Signal +
Pin 3	Signal -

Pin orientation as seen by the user.

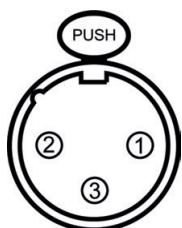
AUDIO 1 / 2 IN

XLR3F socket

Pin 1	Shield
Pin 2	Signal +
Pin 3	Signal -

Pin orientation as seen by the user.

Pinouts Fiber Camera Adapter FCA-1

HEADSET

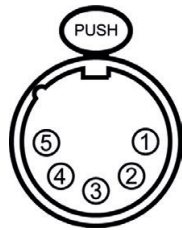

XLR5F socket

Pin 1	MIC H
Pin 2	MIC L
Pin 3	Headphone and MIC GND
Pin 4	Headphone Left
Pin 5	Headphone Right

Pin orientation as seen by the user.

AUDIO OUT

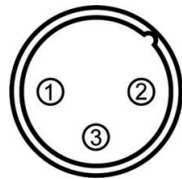

XLR3M plug

Pin 1	Shield
Pin 2	Signal +
Pin 3	Signal -

Pin orientation as seen by the user.

AUDIO 1 / 2 IN

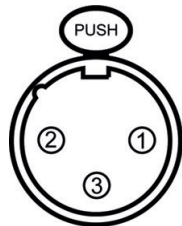

XLR3F socket

Pin 1	Shield
Pin 2	Signal +
Pin 3	Signal -

Pin orientation as seen by the user.

Accessory Power Outputs

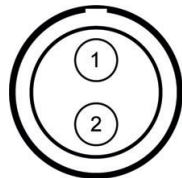

Lemo EGG.0B.302 CLN

Pin 1	Ground
Pin 2	+ 12 V

Pin orientation as seen by the user.

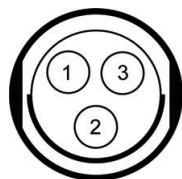

Fischer DBP 102A052-130

Pin 1	Ground
Pin 2	+ 24 V
Pin 3	nc

Pin orientation as seen by the user.

BNC Sockets 75 Ohm

SDI 1 OUT

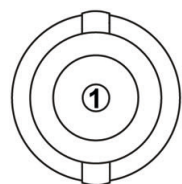

RET OUT

BNC

Pin 1	Serial Digital Video 75 Ohm
-------	-----------------------------

AUX

BNC Sockets 10kOhm

- REF OUT

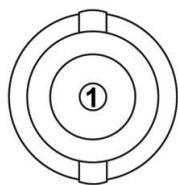

BNC

Pin 1 Genlock I/P Video Signal 10kOhm

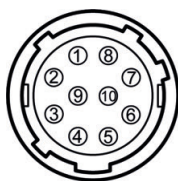
GPIO

Hirose HR10A-10R-10SC 10pin socket

Pin 1	GPIO 1 IN + (dry contact)
Pin 2	GPIO 1 IN – (dry contact)
Pin 3	GPIO 2 IN + (dry contact)
Pin 4	GPIO 2 IN – (dry contact)
Pin 5	GND
Pin 6	GPIO 1 OUT + (relay contact)
Pin 7	GPIO 1 OUT – (relay contact)
Pin 8	GPIO 2 OUT + (relay contact)
Pin 9	GPIO 2 OUT – (relay contact)
Pin 10	+ 12 V / max. 100 mA

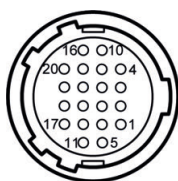
*Pin orientation as seen by the user.***TRACKER**

Hirose HR10A-13R-20S socket

Pin 1	GPIO 3 OUT + (dry contact)	Pin 11	Tracker Microphone return
Pin 2	GPIO 3 OUT – (dry contact)	Pin 12	Tracker Microphone
Pin 3	Tracker intercom to PROD	Pin 13	GND
Pin 4	Tracker intercom to ENG	Pin 14	GPIO 4 IN
Pin 5	Tracker Telephone left	Pin 15	Call indication
Pin 6	Tracker Telephone return	Pin 16	GND
Pin 7	Tracker Telephone right	Pin 17	GPIO 4 OUT + (dry contact)
Pin 8	Not connected	Pin 18	GPIO 4 OUT – (dry contact)
Pin 9	Call switch (GPIO 3 IN)	Pin 19	ON AIR signal green
Pin 10	+ 12 V / max. 100 mA	Pin 20	ON AIR signal red

Pin orientation as seen by the user.

Pinouts Tally Light Module

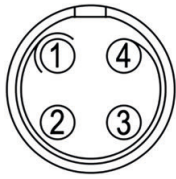

Lemo EEG.0B.304 (0B 4pin, 24 V max. 3 A)

Pin 1	Ground
Pin 2	CAN Low
Pin 3	+ 12 V / + 24 V
Pin 4	CAN High

Pin orientation as seen by the user.

Pinouts Large Lens Adapter Control Module

LBUS

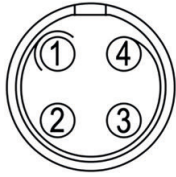

Lemo EEG.0B.304 (0B 4pin, 24 V max. 3 A)

Pin 1	Ground
Pin 2	CAN Low
Pin 3	+ 12 V / + 24 V
Pin 4	CAN High

Pin orientation as seen by the user.

Lens Mount Connector (Hirose)

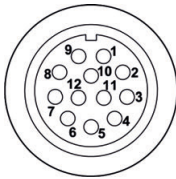

Hirose HR10A-10R-12SCplug

Pin 3	Ground
Pin 6	+ 12 V
Pin 11	RXD (to lens)
Pin 12	TXD (from lens)

Pins not listed above are not connected.

Pin orientation as seen by the user.

POWER IN (XLR 4pin)



XLR4M plug

Pin 1	Ground
Pin 2	Not connected
Pin 3	Not connected
Pin 4	+ 12 V

Pin orientation as seen by the user.

Large Lens Connector (Centronics 36pin)



Centronics 36pin

Pin 4	Lens power
Pin 5	Ground
Pin 6	Ground
Pin 8	RXD (to lens)
Pin 18	TXD (from lens)

Pins not listed above are not connected.

Pin orientation as seen by the user.

10.3 Update Procedures

10.3.1 Update of Camera Software

The camera software is updated with a USB-C medium. The Software Update Package (SUP) updates the camera along with the MVF-2 and the lens mount if they are connected to the camera. Before you update the camera, create the required folder structure on a USB-C medium.

Software Update Package Download

- ▶ Download the software update package (SUP) from the [Software and Firmware Updates for Cameras](#) section on the ARRI website.
- ▶ Double-click on the downloaded file (*.zip) to unpack it. The following files should be created:
 - **Update file** (*.SUP)
 - **Update file** (*.swu)
 - **Update key** (*.lic)
 - **Release notes**
- ▶ Carefully read the release notes.
- ▶ Copy the update file (*.swu) to folder ARRI/ALEXA35/SUP on the USB-C medium.
- ▶ Copy the update key (*.lic) to folder ARRI/ALEXA35/LICENSES on the USB-C medium.

Camera Update

- ▶ Connect the USB-C medium stick to the camera.
- ▶ If inserted, remove the recording media from the camera.
- ▶ Select *MENU > Setup > Factory Reset* to perform a factory reset.
- ▶ Select *MENU > System > Update > Update Camera*.
- ▶ Select the required update file and push the *CONFIRM* button to start the update.
- ▶ Check the MVF-2 monitor for the update progress.
- ▶ Wait for the update process to finish. The update procedure takes about ten minutes.

After a successful update and reboot, the camera shows a success message.

10.3.2 Update of Camera Components

The camera supports update of the MVF-2 viewfinder and the lens mount. The MVF-2 and the lens mount do not require a dedicated update file. The camera shows a message if the software version of MVF-2 and / or the lens mount does not match the version required by the currently installed camera software.

- ▶ Select *MENU > System > Update*.

The Update MVF-2 and Update Lens Mount entries show the software version installed on the component and the software version required by the currently installed camera software.

- ▶ Select *Update MVF-2* to update the MVF-2 or
- ▶ Select *Update Lens Mount* to update the lens mount.
- ▶ Push *CONFIRM* to start the update.

10.3.3 Update of Fiber Base Station and Fiber Camera Adapter

The Fiber Base Station FBS-1 and Fiber Camera Adapter FCA-1 software are updated using a computer and the LPS-1 Web UI.

Installed Version

- ▶ Enter the IP address of the Fiber Base Station FBS-1 in the address bar of a web browser to open the LPS-1 Web UI.

- ▶ Select *Settings > Firmware Updater* to check the currently installed versions of the Fiber Base Station and the Fiber Camera Adapter FCA-1 .

Update Procedure

- ▶ Download the software update package (SUP) from the [Software and Firmware Updates for Cameras](#) section on the ARRI website.
- ▶ Double-click on the downloaded file (*.zip) to unpack it. This will extract one update file to your computer (*.raucb).
- ▶ Carefully read the release notes.
- ▶ After downloading the update file from the Software Update Packages section of our website, double-click the downloaded .zip file to unpack it, or unpack it manually. This will extract one update file to your computer (*.raucb).
- ▶ Enter the IP address of the Fiber Base Station FBS-1 in the address bar of a web browser to open the LPS-1 Web UI.
- ▶ Select *Settings > Firmware Updater > Update All* if the update file name does not include the identifier "FCA".
- ▶ Select *Settings > Firmware Updater > Fiber Camera Adapter > Upload* if the update file name includes the identifier "FCA".
- ▶ Select the required update file from your computer and start the update. Wait for the update process to finish. The update procedure takes about five minutes.
- ▶ After the update has finished, reboot the Fiber Base Station FBS-1 . Do not initiate the reboot through the button on the LPS-1 Web UI. Use the power button on the Fiber Base Station FBS-1.
- ▶ After the reboot, reload the *Settings page* of the LPS-1 Web UI and check the Installed Firmware version.

10.4 LPS-1 Accessories

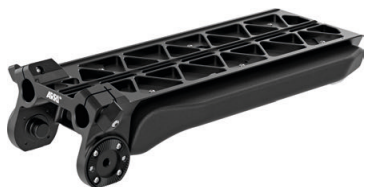

Touchdown Base Plate TBP-1 K2.0049959

The Touchdown System comprises the Touchdown Receiver Plate TRP-1 and the Touchdown Base Plate TBP-1, with built-in long shoulder pad, 15 mm rod support, and ARRI rosettes. Together, they offer a new camera mounting system that is lightweight, self-aligning, super-stable when used on a tripod, and capable of rapid transitions to handheld operation.



Touchdown Receiver Plate TRP-1 K2.0049960

The TRP-1, in combination with the TBP-1, is a new system for attaching a camera to a tripod that is faster to use and more secure than the traditional VCT-14. It has less side-to-side wobble and is self-aligning, making it easy to attach when the camera is mounted high or low.



Tally Light Module TLM-1 K2.0050656

This LBUS tally light with 16-segment, alphanumeric camera ID display has a versatile mounting interface and connects to the camera through an LBUS cable. Rugged and durable, the TLM-1 offers daisy-chainable LBUS connectivity.



RIA-1 Bracket K2.0039465

L-shaped bracket with two 3/8" screws and anti-twist locating pins. Can be used to attach the Tally Light Module TLM-1 to the camera.



Large Lens Adapter LLA-1 K2.0050774-2

The Large Lens Adapter LLA-1 allows instant mounting of ARRI cameras to large box lenses, without tedious alignment procedures. The LLA-1 is lightweight and strong, providing multiple mounting options for accessories and cable management. Compatible with all PL and B4 box lenses, it is available with a cable to connect a PL mount (Hirose) to a box lens, as well as a rain cover and a flight case.



LLA-1 Control Module K2.0051099

The LLA-1 Control Module connects a box lens with a 36pin Centronics connector to the camera. It allows control of focus, zoom, and iris through the camera or a remote control panel. It converts the Centronics interface to LBUS and Hirose for electronic control of the lens when using a PL Mount (Hirose), a PL Mount (LBUS), or an LPL Mount (LBUS).



Cable Hirose to Box Lens K2.0050125

This 35 cm long cable connects the Hirose 12-pin connector of the ARRI PL Mount (Hirose) to a large box lens mounted to the ARRI Large Lens Adapter LLA-1. The cable is secured to the LLA-1 by a custom bracket screwed on the large lens adapter unit.



LLA-1 Plate for ALEXA Mini/LF K2.0050776

This adapter plate enables all ARRI ALEXA Mini and ARRI ALEXA Mini LF cameras to mount on the ARRI Large Lens Adapter LLA-1.



LLA-1 Plate for AMIRA K2.0050775

This adapter plate enables all ARRI AMIRA cameras to mount on the ARRI Large Lens Adapter LLA-1.



ALEXA 35 Multicam Support Set 2 KK.0055173

The Multicam Support Set 2 for ALEXA 35 Live includes the innovative ARRI Touchdown system and the Live Production Handle LPH-2, featuring an integrated NATO rail designed to support monitor systems such as the LPM-1, which mounts directly for use in live production environments.

The ALEXA 35 Multicam Support Set 2 includes:

- 1 x K2.0049422, Top Operator Plate TOP-1
- 1 x K2.0049959, Touchdown Base Plate TBP-1
- 1 x K2.0049960, Touchdown Receiver Plate TRP-1
- 1 x K2.0054985, Live Production Handle LPH-2



Monitor Yoke Support MYS-2 for LPM-1 K2.0054147

The Monitor Yoke Support MYS-2 is designed for use with the Live Production Monitor LPM-1 only. The MYS-2 supports the monitor and allows for counterbalanced, four-axis adjustment of the monitor.



Live Production Monitor LPM-1 Basic Set KK.0055403

Live Production Monitor LPM-1 Pro Set KK.0054652

The Live Production Monitor LPM-1, a 10-inch onboard display and control interface that makes the cinematic ALEXA 35 Live – Multicam System an even more compelling broadcast solution. Offering flexible connectivity and controls, the LPM-1 perfectly complements ARRI's ALEXA 35 Live camera and Live Production System LPS-1, seamlessly integrating into professional live production environments. The adjacent figure shows the LPM-1 with the Monitor Yoke Support MYS-2.



LLA-1 / BUD Slider Plate K2.0055339

The LLA-1/BUD Slider Plate is the successor to the LLA-1 Plate and enables the secure mounting of all ALEXA 35 cameras on the ARRI Large Lens Adapter via an integrated locking mechanism. The plate also secures the camera when no lens is mounted, addressing broadcast workflows where cameras may be parked on the LLA-1 without a lens attached. Clear tactile and visual feedback confirms correct and safe locking. Designed as a lightweight solution, the LLA-1/BUD Slider Plate follows the design philosophy of its predecessor (K2.0050777) while ensuring full compatibility with all ALEXA 35 camera variants on the ARRI Large Lens Adapter.



camRade rainCover OB-EFP Large K2.0050817

A rain cover that fits over camera, Large Lens Adapter and box lens.

LPS-1

Live Production System