



L-Series®

L7

User Manual

October 2022

© 2016-2022 Arnold & Richter Cine Technik GmbH & Co. Betriebs KG (ARRI). All rights reserved.

Information subject to change without notice. ARRI and all affiliated companies disclaim liability for any injury, damage, direct or indirect loss, consequential or economic loss or any other loss occasioned by the use of, inability to use or reliance on the information contained in this document. The ARRI logo, the ARRI name and all other trade-marks in this document pertaining to services or products by ARRI or its affiliates and subsidiaries are trademarks or licensed by ARRI or its affiliates or subsidiaries.

ARRI, the ARRI Logo, ARRIMAX, ARRISUN, EB, **LOS**, L-Series, MAX Technology, M-Series, Orbiter, POCKETPAR, Quick Lighting Mount, QLM, True Blue, SkyPanel, SKYPANEL, Stellar, T12 as well as the blue/silver color combination are registered trademarks of the Arnold & Richter Cine Technik GmbH & Co. Betriebs KG.

No part of this document may be used for distribution, reproduction, transmission, transcription, storage in a data retrieval system, or translated into any language in any form by any means without the prior written permission of ARRI. If you are downloading files from our web pages for your personal use, make sure to check for updated versions. ARRI cannot take any liability whatsoever for downloaded files, as technical data are subject to change without notice.

L5.31899.0, Rev. L03974

Dimensions

L7 man.

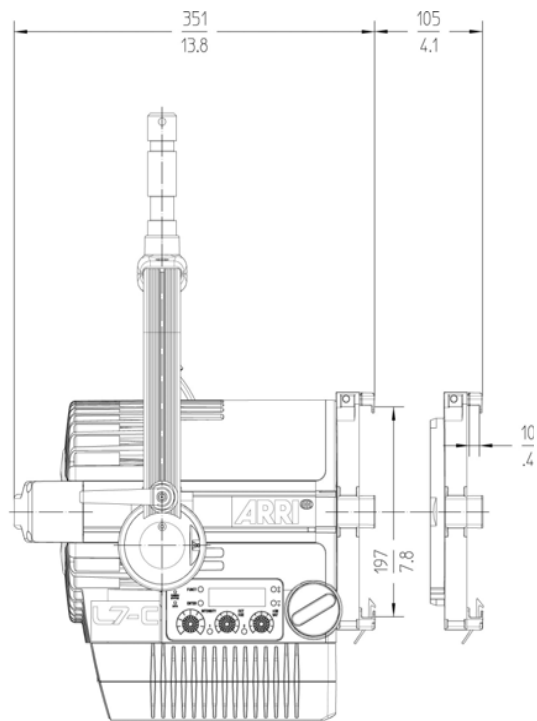
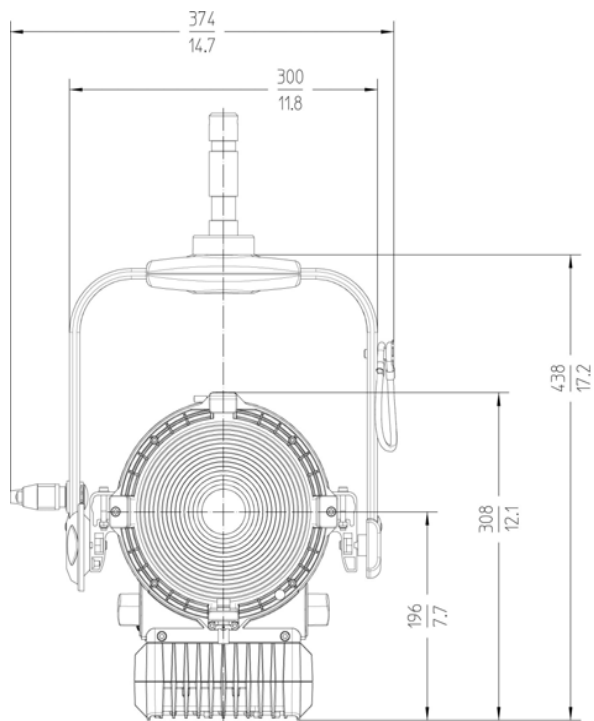

L7 P.O.

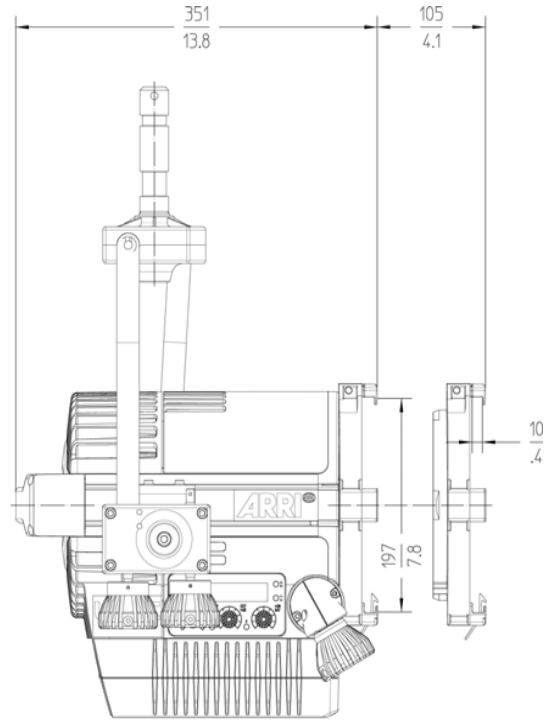
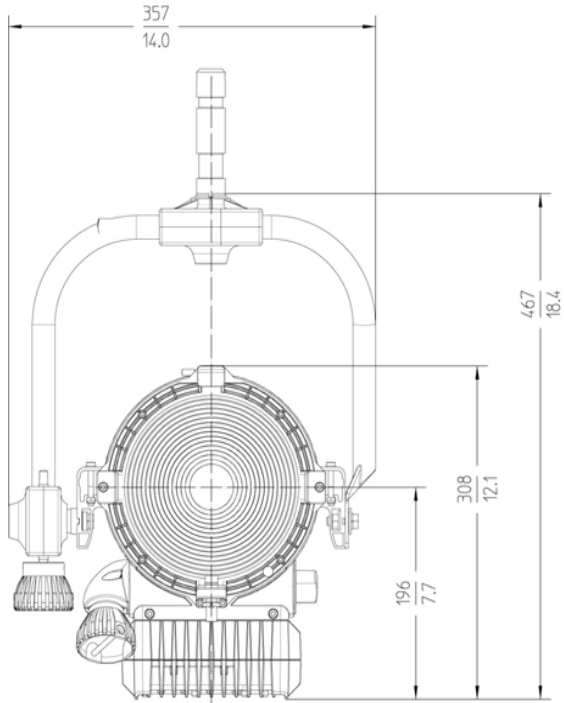

Content

Dimensions3
Content5
Safety Information6
Introduction	10
Features	10
Properties	11
Unpacking	11
Overview	12
Physical Installation	14
Basic features	15
Control options	16
Connector panel	16
Power	17
Fixture Menu	18
DMX control	25
DMX mode	25
DMX data link	26
Fixture Menu	27
RDM commands	29
ARRI Lighting Service Manager	29
Error Messages	30
DMX Protocol	31
Specification	42

Safety Information



Always follow these instructions to protect against injury to yourself and damage to the product or other objects.

Explanation of Warning Signs and Indications



Possible risk of injury or damage to equipment.



Risk of fire or electric shock. Possible risk of injury or damage to equipment.



Caution! Hot surface. Possible high surface temperature. Risk of injury through burns.



Caution! High intensity light emission. Risk of eye injury.

Note: Indicates further information.

General Notes

- This document contains important instructions and notes to handle the product safe.
- Always follow all safety information for your own protection.
- Please contact a trained ARRI® service technician to do any service and maintenance not described in this manual.
- Read the user manual and installation manual which are shipped with accessories for the product.
- Retain this user manual and all user and installation manuals shipped with the system for further reference and possible new owners of this product.
- This product is intended for professional use and may only be operated by qualified persons. They are not for household use.
- Help protecting the environment by disposing the package material at your local recycling center.
- All components comply to the guidelines listed below:
 - Low voltage directive 2014/35/EU
 - EMC directive 2014/30/EU
 - RoHS directive 2011/65/EU

General Safety Information



Read and understand all safety information and operation instructions before you operate or install the product or the system.



Use only genuine spare parts or accessories that have been recommended or approved by ARRI. Other accessories or spare parts may cause hazards, damage the product or invalidate the warranty.



Check all cables and devices for visible damage before you work with the system. Defective electric or electronic devices must not be used. Take special care of the following components:

Component	Possible damage
Housing, lens	Cracks, cuts, deformation
Cables	Cuts, deformation, burns
Connectors	Cracks, deformation, burns
Cable connectors	Damaged
Threads	Damaged



If the product or accessory is visibly damaged, the product or accessory must no longer be used. Replace or repair the respective part. In case of repairs, please contact an authorized ARRI service center.



Never attempt to repair any part of the product on your own. Maintenance and repair work is only to be carried out by an authorized ARRI service center.



Do not operate active versions the product if the ambient temperature exceeds 45° C / 113° F (hybrid versions: 35° C / 95° F). Observe all information given in chapter "Specification" on page 42.



Do not expose the product to rain or moisture. Do not use the product for 2 h when it was exposed to big temperature differences as condensed moisture may damage the product electrically when switched on.



Do not bypass any safety feature of the product.



Do not open the product. There are no user serviceable parts inside. The housing is sealed with an adhesive seal that will break immediately when trying to open the housing. Doing so will invalidate the warranty.



In addition to regular visible checks ARRI recommends that all electric components are checked for electrical safety by a professional every 12 month. Keep the protocol of the check.

Specific Safety Information



Intensive use can cause the surface and the heat sink to become warm. Let the product cool down complete before you handle it.



Never cover air vents and the heat sink during operation. Keep a minimum clearance around the product of 0.5 m / 1.65 ft.



WARNING! Intense light. Never look direct into the light source.



Never point a light beam from another luminaire into the light source. Do not place the product on heat sources. Intense heat cause automatic power off during operation.



WARNING! The stirrup must be mounted hanging or standing vertically. Lateral load can cause deformation or breaking of the spigot and the stirrup.



Devices and accessories must be secured against fall when mounted above floor level. Always observe common and local safety regulations.



Never use the cables for transportation. Never hang the product on its cables.



CAUTION! High voltage! Always disconnect the product complete from mains voltage before you connect or disconnect a cable!



Always check that the local AC power matches the voltage and frequency range printed on the type label of the product before use. Never use the product when the AC power does not match.



Never connect the product to a dimmer-system or a dimmer-channel in non-dim mode. To do so will damage the electronics. Damages caused by connecting the product to a not suitable power source are not covered by the warranty.



Always keep cables away from the product during operation. Do not tilt the power cable directly after the cable glance. Water could immerse and cause short circuits and damage the connector.



Disconnect all data cables prior to transport.



Not to observe these safety information or to ignore common sense may cause serious injury or even death. Damage to the product or other devices is possible.

Please observe the information given in the „Safety leaflet ARRI lampheads“ (L5.40731.E). The leaflet is available for download on our web site www.arri.com.



Please observe the NEUTRIK PowerCON True1 safety information from November 2017. The safety information is available for free download in the service area of the ARRI website www.ari.com.

To Replace the Light Source

The light source contained in this luminaire shall only be replaced by the manufacturer or his service agent or a similar qualified person.

Maintenance Information

- Do not clean the surface of the product with solvents or strong detergents.
- Clean the product with a soft cloth wetted with a mild detergent. Do not rub the surface: lift stuck particles off with a soft repeated press.
- Clean soiled electric contacts with cotton swabs wetted with isopropyl alcohol.
- Keep electric contacts clean and replace corroded parts.

Intended use

This product is intended to illuminate persons and objects in a dry environment.

Always follow the safety information.

Any usage other than described above is not permitted and can damage the product and lead to associated risks such as short-circuit, fire, electric shock, etc. You are not allowed to modify the product.

This product fulfills European and national requirements.

Introduction

Thank you for selecting a LED luminaire of the L-Series from ARRI. The L7 is a fresnel-luminaire equipped with a high precision, micro-processor controlled LED light source. LED luminaires are much more efficient than light sources with conventional tungsten lamps. They are a perfect and easy replacement for conventional fresnel-luminaires with tungsten or daylight lamps.

The L-Series LED luminaires combine the advantages of the LED technology with the ease of use of a traditional fresnel-luminaire. The L7 integrates seamlessly into established working practice. The optical system offers real fresnel characteristics with an extreme smooth beam and clean shadows. The half peak angle can be adjusted continuously from 15° - 50°.

The L7 emits white or colored light with adjustable color temperature and adjustable green / magenta saturation. Please find more detailed information in the section "Specification" on page 42. The light spectrum is optimized for excellent color rendition and fulfills perfectly the demands of modern, digital cameras. All models of the L7 can be controlled using the common DMX512-A protocol or the fixture menu.

The L7 can be powered by AC power. Please find more detailed information in the section "Power" on page 17.

Features

Focus

Traditional fresnel-luminaires are able to spot and flood the beam as needed. Whether it is a flood field for a pullback or a tight spot for a bright highlight, the continuous focusability of the L7 performs just as expected.

Versatile beam characteristics

The L7 provides the same ability as conventional fresnel-luminaires to cut set elements and shape the beam with barndoors and flags.

Even light field

Clean, defined shadows have traditionally been a trait of single source tungsten and daylight fixtures. L7 fresnel-luminaires provide the same single shadow properties lighting designers expect, delivering natural results.

Vibrant colors, full spectrum lighting

True-to-life color rendition is an outstanding feature of the L7, comparable to a full spectrum tungsten source. The fully tuneable white light of the L7-C can be adjusted for different skin tones, camera sensors and mixed light environments. Full gamut color mixing enables the rendition of all color shades, making color filters dispensable.

Cool light beam

Like all LED light sources the L7 does emit nearly no infrared or UV radiation and thus does not forward heat, making actors feel comfortable in the light beam.

Properties

Focus knob

The TRUE BLUE® style focus knobs provide precise adjustment and rapid flood-to-spot with only a few turns. Knobs on both sides of the fixture ensure easy access from all positions.

Sliding stirrup

The sliding stirrup design enables precise compensation for front end accessories.

Yoke

With an extreme slim profile, the extruded aluminum yoke provides high strength without added weight. An optional, pole operated yoke allows full operation of pan and tilt from the floor and is therefore a popular choice for many studios.

Tilt-lock

The high strength tilt-lock provides extreme secure locking. It eliminates movement and slippage and ensures that the light beam will stay where you put it.

DMX-control

All functions of the L7 are controllable through DMX. The L7 is also fully RDM compatible and is equipped with a feedback channel for reporting all set parameters including system status.

Fixture menu

For location applications the L7 is equipped with a fixture menu for manual adjustment of intensity, color temperature and plus/minus green as well as hue and saturation (functions available depending on version).

Unpacking

The L7 is supplied with:

- Power cable with power plug or bare ends and in line switch (depending on version)
- Stirrup
- 28 mm spigot (mounted on p.o. stirrups)
- Short instruction

Overview

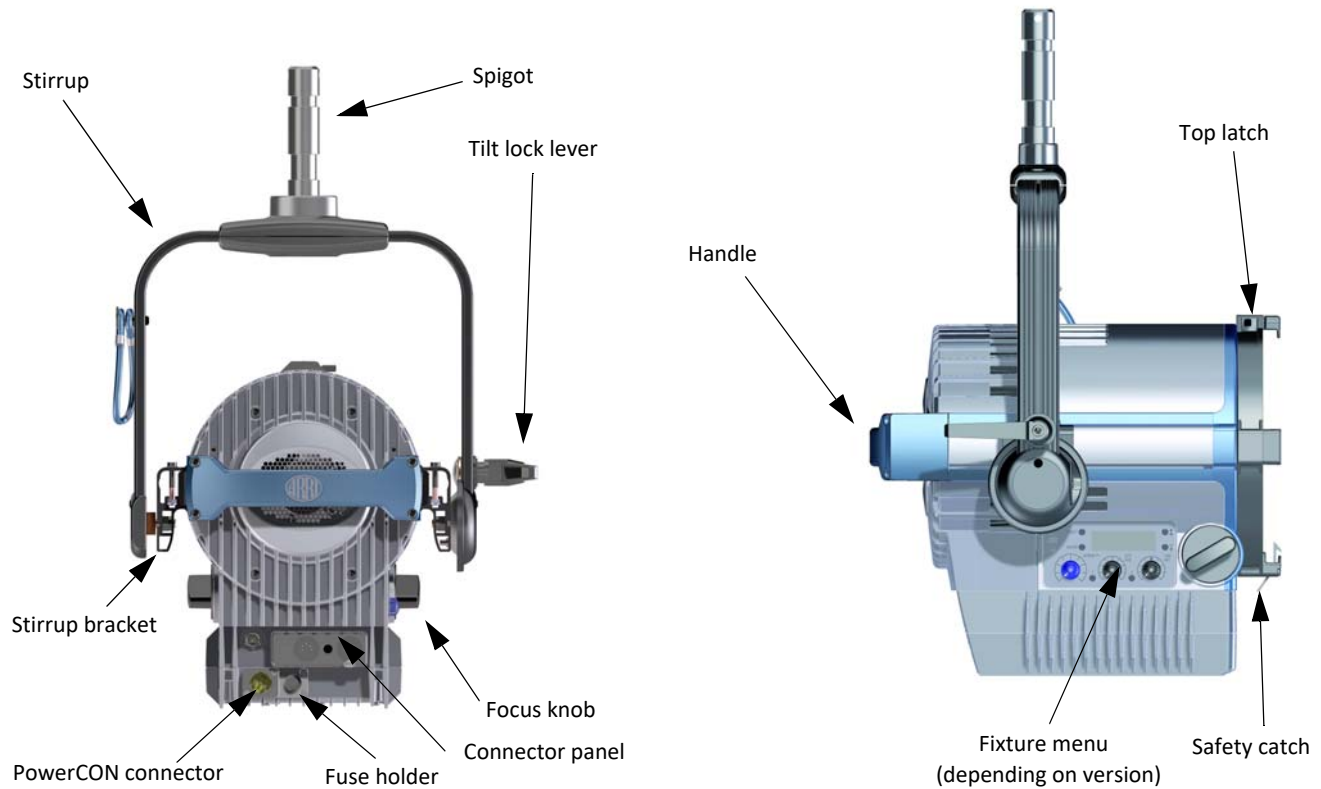

Front view and back view, manual version

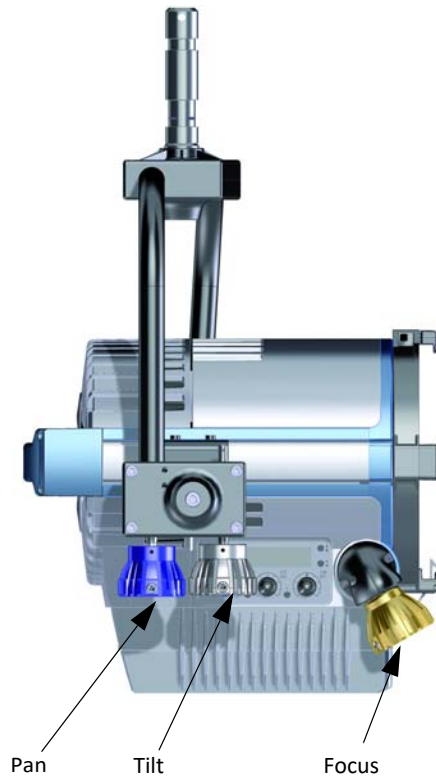

Side view, P.O. version

Physical Installation



WARNING! Attach an approved safety-cable to secure the product against clamp or bracket failure. Lead the safety-cable through the stirrup and keep it as short as possible. The safety-cable needs to be approved at least 10 times the weight of the product including all accessories mounted at the product. Secure all accessories mounted at the product with additional safety-cables to protect them from fall down and cause injuries and damages.



WARNING! The rigging structure needs to be approved for at least 10 times the weight of all devices, equipment and cables installed on it.



WARNING! The stirrup must be mounted hanging or standing vertically. Lateral load can cause deformation or breaking of the spigot and the stirrup.



CAUTION! Block access below the work area and work from a stable platform whenever installing, servicing or moving the product or accessories.



IMPORTANT! Do not illuminate the display and the fresnel-lens by high power light beams from a short distance. The display and the light engine are damaged by high brightness and heat radiation within very short time.

To adjust the stirrup

You need

- a Torx20 screw driver,
- a 10 mm allen key and
- a torque wrench (37 ft-lbs)

to adjust the stirrup.

On delivery the stirrup is in the basic position (tilted back). Loosen the Torx20 screws on both sides of the stirrup bracket slightly and pull the stirrup bracket towards the rear of the product. Loosen the lever of the tilt-lock and tilt the stirrup upwards.

Slide the stirrup to the point of balance. The point of balance is dependent on the accessories mounted at the product. Tighten both Torx20 screws of the stirrup brackets. Do not overtighten the screws. Tilt the stirrup to the desired position and tighten the tilt-lock by using the lever. For better leverage, press the knob on the tilt-lock-lever and turn the lever to the desired position.

To mount the spigot

Place the spigot and the distance plate on the 13 mm hole in the middle of the stirrup. Insert the allen screw with washer and spring washer and tighten it with a torque wrench to 37 ft-lbs torque.

To mount the device

Always observe all safety information listed in section “Physical Installation” on page 14 when you mount the product and accessories:

- Be aware of the maximum tilt angle 90° upwards and 90° downwards.

Ensure that you install all accessories correct when you mount the product above floor level:

- Top latched locked, safety catch snapped in.
- Set up tripods in a stable position. Tripods need to be approved for the load they need to carry.
- Always observe the additional load of cables and accessories!

Please observe the information given in the „Safety leaflet ARRI lampheads“ (L5.40731.E), which is available for download on our web site www.arri.com.

Basic features

Pan and tilt

Loose the mounting screw of the tripod or the appropriate fixing screw of the mounting clamp to pan the L7. Tighten the screw to avoid unintended movement. Loose the tilt-lock to tilt the L7 to the desired angle. Tighten the tilt-lock-lever to avoid unintended movement.

To adjust the beam angle

Turn one of the focus knobs beneath the lens tube to adjust the beam angle continuously. The entire lens tube moves in and out. Two mechanisms protect the product from being damaged:

- A predetermined braking point prevents the product from damage, when the focus knob is turned with too high torque at either end of the focus range.
- The self-impeding focus gear prevents the lens tube to move itself in or out when the product is operated in a tilted position.

Use of accessories for beam shaping and light design

You can mount accessories such as a barndoor, filter holder or scrim on the front side of the L7:

- Firmly press the button at the side of the top latch to open the top latch.
- Insert the accessory from the upside into the brackets until the safety catch engages. Slightly tilt the safety catch with your finger for support.

- Close the top latch. Make sure that the hook of the top latch engages into the holding ring of the accessory.

DMX/RDM-interface

The L7 has a DMX/RDM-interface. It has 5-pin XLR connectors for DMX/RDM data input and throughput. Please find more detailed information to establish a DMX/RDM data-link in section “DMX data link” on page 26.

USB-interface

The L7 has a mini-USB connector to upload firmware and set parameters. The USB-interface can be used for service purpose like download error reports and set certain data. To do so you need a software tool, the ARRI Lighting Service Manager ALSM.

Download it free of charge from the ARRI web site www.arri.com.

Please find more detailed information to work with the ALSM in the user manual of the software. The manual is included in the download package.

To turn on and use the product

Turn on the in line power switch or connect the L7 to AC power. The L7 initializes for some seconds and is ready for operation. The L7 will operate with the settings made on the fixture menu or received by DMX. Please observe the following section to use the L7.

Control options

You can set up or control the L7 with the options listed in the table below:

Option	Control	Configuration	Information
Fixture menu	yes	yes	page 18
DMX	yes	no	page 25
RDM	no	yes	page 29
ALSM	no	yes	page 29
Stellar App	yes	no	www.arri.com

Connector panel

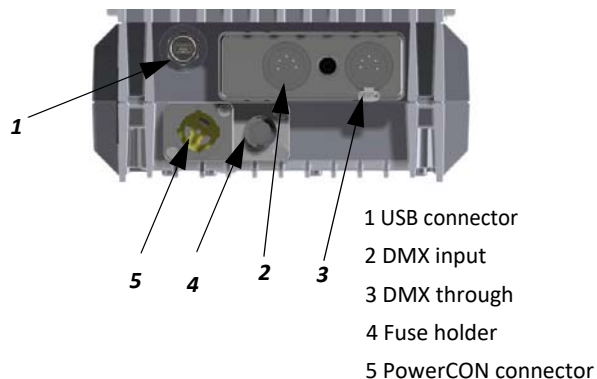

Power



WARNING! For protection from electric shock, always connect the product electrically to ground (earth) when connected to AC power. The AC mains power supply must be fitted with a fuse or circuit breaker and ground-fault (earth-fault) protection.



IMPORTANT! Ensure that persons do not look at the light emission aperture when the product is connected to AC power. The product can light up suddenly. The high intensity of the product can cause eye irritation or injury when not respecting the safety distance.



IMPORTANT! Always connect the product direct to AC power. Do not connect it to a dimmer-system. Doing so will damage the product.

AC power

The L7 has an auto-sensing switch-mode power supply that automatically adapts to AC power at 100 - 240 V ~, 50 - 60 Hz (nom.).

Before you connect the L7 to AC power, check that:

- the dimmer knob at the fixture menu is set to 0%, and
- no DMX signal is present at the DMX-input of the L7.

You can hard-wire the L7 to a building electrical installation.

You can install a power plug that is suitable for the local power outlets on the power cable. Socket outlets or external power switches that supply the L7 with power must be located near the product and easily accessible so that the L7 can easily be disconnected from power.

The L7 requires a power input cable with a Neutrik® PowerCON® True1 NAC3FX-W cable connector. Cable requirements are listed in chapter “Specification” on page 42.

ARRI offers power cables with PowerCON® cable connectors and different plugs or bare ends.

To insert and remove the PowerCON® cable connector

- Line up the raised key of the connector and the keyway of the input socket. Insert the cable connector without force in the power input socket.

To lock the cable connector:

- Turn it a full quarter-turn clockwise.

To unlock the cable connector:

- Push the connector lock backwards and turn the cable connector counter-clockwise. Pull the cable connector out of the power input socket.

Fixture Menu

Depending on the model, the L7 is equipped with one of the following display or control panels:

Simple display field



Fixture menu with LC display and dimmer knob

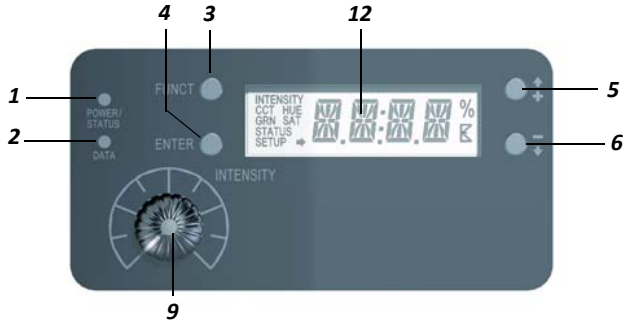

Fixture menu with LC display, dimmer knob and color control

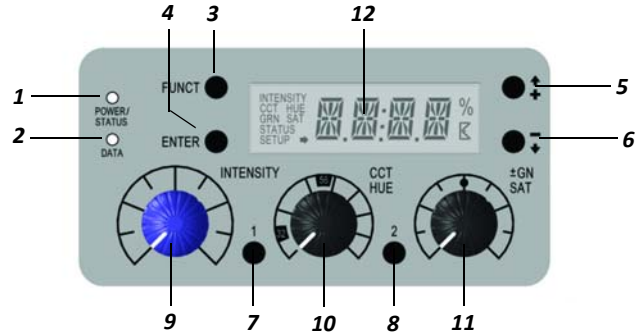

Features of the fixture menu

Status indicator POWER/STATUS (1):

Color	Indication
Green	Fixture switched on. No error.
Red flashing (0,5s rhythm)*	Warning fixture over temperature
Red*	Fixture over temperature
Change from red to green*	Fixture normal temperature
Red flashing (0,25s rhythm)*	Calibration data not loaded

*Display lights up red when STATUS-LED is lit red

DATA (2)

The DATA indicator lights blue, when a valid DMX signal is detected on the DMX-input.

FUNCT (3)

The FUNCT button has two functions:

- Normal operation: Switches between CCT and HSI mode (only L7-C).
- Fixture menu open: Jump UP one menu level.

ENTER (4)

The ENTER button has three functions:

- Normal operation: Activate blinking arrow for calling up MEM1 or MEM2.
- Fixture menu open: OPEN next menu level, or
- Confirm a setting.

+ / [up] (5)

The + / [up] button navigates the menu or increases a value. Press the button long to activate the fast-run feature.

- / [down](6)

The - / [down] button navigates the menu or decreases a value. Press the button long to activate the fast-run feature.

INTENSITY (9)

The rotary knob sets the intensity level.

CCT / HUE (10)

The rotary knob sets the color temperature (CCT) or the hue (only L7-C in color mode).

GN / SAT (11)

The rotary knob sets the green/magenta saturation or the color saturation (SAT, only L7-C in color mode).

MEMORY 1 and MEMORY 2 (7 and 8)

Activate or store a memory.

During operation the mode and recent values are displayed. On the first menu level the values for INTENSITY, CCT/HUE (only L7-C) and GN/SAT (only L7-C) can be retrieved via the + / [up]/- / [down] buttons. The menu STATUS, confirmed with ENTER, calls up the next level which displays information on faultless operation and the temperature of the light engine. To retrieve values for operating hours, DMX-version and firmware-version, press ENTER to call up the third level. The FUNCT button jumps up one menu level.

A detailed overview of the fixture menu is listed in section "Fixture Menu" on page 27.

To set the operation mode (only L7-C)

Press the FUNCT button to switch from CCT mode to HSI mode and vice versa.

In CCT mode the L7 generates white light with optimized color rendition. In HSI mode the L7 generates colored light. If saturation is set very low, the L7 generates white light, but not with optimized color rendition.

To set the color temperature and green/magenta saturation in CCT mode

Set the color temperature continuously with the rotary knob CCT/HUE. Set the green/magenta saturation continuously with the rotary knob GN/SAT.

Press the + / [up] or - / [down] button until GRN is displayed left in the display (e.g. +0.23) to retrieve the currently set green/magenta value. The color temperature is always displayed (e.g. 4.150K).

To set the color in HSI mode (only L7-C)

Set the hue continuously with the rotary knob CCT/HUE. Set the saturation continuously with the rotary knob GN/SAT.

Press the + / [up] or - / [down] button until SAT is displayed left in the display (e.g. 45) to retrieve the currently set saturation value. The hue is always displayed (e.g. 118°).

To set the brightness in both operating modes

Set the brightness in both operating modes continuously with the rotary knob INTENSITY

Press the + / [up] or - / [down] button until INTENSITY is displayed left in the display (e.g. 24%) to retrieve the currently set brightness value.

To set the fan mode

Set the fan mode using the fixture menu:

- Press the + / [up] or - / [down] button, until SETUP is displayed left in the display.
- Confirm with the ENTER button. Press the + / [up] or - / [down] button until FAN is displayed.
- Confirm with the ENTER button. The current fan mode is displayed.
- Press the + / [up] or - / [down] button to select the fan mode (see the table below). Confirm the selected mode with the ENTER button. The fan mode is activated immediately.
- Press the FUNCT button two times to leave the menu.

Mode	Hybrid	Active	Description
OFF	X		The fan is turned off, it may occur that the lamphead turns itself off due to overheating. Once the lamphead has cooled down it can be turned on and used again.
LOW	X	X	The fan operates constantly at low speed (silent).
HI	X		The fan operates constantly at maximum speed.
A-LOW	X		The fan operates from 80% intensity with 1050 rev/min.
A-HI	X		The fan operates from 80% intensity with maximum speed.
VARI	X	X	The fan is controlled via the light-engine temperature.
PASS	X		No fan, light output is reduced by 20%.
HI45		X	Optimized for an ambient temperature of 45°C / 113° F, the fan operates at max. speed, light output is reduced by approx 15%.

To set the DMX address

- Press the + / [up] or - / [down] button, until SETUP is displayed left in the display.
- Confirm with the ENTER button. Press the + / [up] or - / [down] button until DMX is displayed.
- Confirm with the ENTER button. Press the + / [up] or - / [down] button until CHAN is displayed.
- Confirm with the ENTER button. The current DMX address is displayed.
- Press the + / [up] or - / [down] button to select the DMX address. Confirm the selected address with the ENTER button. The DMX address blinks three times for confirmation.
- Press the FUNCT button to leave the menu.

To set the Signal lost behavior

Set the signal lost behavior:

- Press the + / [up] or - / [down] button, until SETUP is displayed left in the display.
- Confirm with the ENTER button. Press the + / [up] or - / [down] button until DMX is displayed.
- Confirm with the ENTER button. Press the + / [up] or - / [down] button until LSIG is displayed.
- Confirm with the ENTER button. The current setting is displayed.

The following options are available:

- HOLD: The last received DMX values are used until the L7 is switched off or valid DMX data is received again.
- BOUT: The L7 douses to 0% intensity.
- H2MF: The last received DMX values are used for 2 minutes. After 2 minutes the L7 douses to 0% intensity. When valid DMX data is received after less than 2 minutes, these data will be used.
- Press the + / [up] or - / [down] button to select the signal lost behavior. Confirm the selected mode with the ENTER button. The option blinks three times for confirmation.
- Press the FUNCT button to leave the menu.

To set the DMX mode

Set the DMX mode using the fixture menu:

- Press the + / [up] or - / [down] button, until SETUP is displayed left in the display.
- Confirm with the ENTER button. Press the + / [up] or - / [down] button until DMX is displayed.
- Confirm with the ENTER button. Press the + / [up] or - / [down] button until PROT is displayed.
- Confirm with the ENTER button. The current DMX mode is displayed.
- Press the + / [up] or - / [down] button to select the DMX mode. Confirm the selected mode with the ENTER button. The DMX mode blinks three times for confirmation.
- Press the FUNCT button to leave the menu.

To set the display illumination and status indicators

To switch the display illumination and status indicators on or off:

- Press the + / [up] or - / [down] button, until SETUP is displayed left in the display.
- Confirm with the ENTER button. Press the + / [up] or - / [down] button until INDC is displayed.
- Confirm with the ENTER button. The current setting is displayed.

- Press the + / [up] or - / [down] button to select the option ON or OFF. Confirm the selected mode with the ENTER button.
- Press the FUNCT button to leave the menu.

To read out fixture information

To display fixture information:

Operating hours

- Press the + / [up] or - / [down] button, until STATUS is displayed left in the display.
- Confirm with the ENTER button. Press the + / [up] or - / [down] button until HOUR is displayed.
- Confirm with the ENTER button. The current operating hours are displayed (e.g. 501h).
- Press the FUNCT button to leave the menu.

Version of the DMX protocol

To display the version of the DMX protocol:

- Press the + / [up] or - / [down] button, until STATUS is displayed left in the display.
- Confirm with the ENTER button. Press the + / [up] or - / [down] button until DMXV is displayed.
- Confirm with the ENTER button. The current version is displayed (e.g. 3.1).
- Press the FUNCT button to leave the menu.

Firmware-version

To display the firmware-version:

- Press the + / [up] or - / [down] button, until STATUS is displayed left in the display.
- Confirm with the ENTER button. Press the + / [up] or - / [down] button until SW is displayed.
- Confirm with the ENTER button. The current firmware version is displayed (e.g. 2.00.2).

Recent temperature

To display the recent temperature of the light engine:

- Press the + / [up] or - / [down] button, until STATUS is displayed left in the display.
- Confirm with the ENTER button. Press the + / [up] or - / [down] button until the temperature (e.g. 42,1°) is displayed.
- Press the FUNCT button to leave the menu.

Error status

To display the error status:

- Press the + / [up] or - / [down] button, until STATUS is displayed left in the display.
- Confirm with the ENTER button.
- If there is no error, OK will be displayed. Otherwise the error code is displayed (see "Error Messages" on page 30).
- Press the FUNCT button to leave the menu.

Short cuts

The demo mode, setting the DMX address and DMX mode can be called up via short cuts in the fixture menu:

- Press and hold the ENTER button, until JUMP is displayed in the display (from every menu).
- Press and hold the FUNCT button to activate the demo mode. Press the ENTER button again to deactivate the demo mode.
- Press the + / [up] button to set the DMX address.

- Press the - / [down] button to set the DMX mode.

The JUMP menu closes 3 sec. after the last key press or after pressing the ENTER button.

Demo mode

In demo mode the L7 calls up an endless loop with all features the L7 supports.

- **L7-TT and L7-DT:** Change of the color temperature from warm to cold and vice versa. Set the intensity with the dimmer knob. Set the speed with the CCT knob from 0-100% (60 s - 1 s).
- **L7-C:** Call up the color spectrum or change the color temperature from warm to cold and vice versa. Set the intensity with the dimmer knob. Set the speed with the CCT knob from 0-100% (60 s - 1 s). The GN knob sets the saturation and changes between color and color temperature sequence. With GN at „0“ the color temperature loop is active. Turn the GN knob clockwise to increase the saturation to 100%.
- Press the JUMP and FUNCT button or the FUNCT button alone to deactivate the demo mode.

As an alternative activate and deactivate the demo mode in the menu Setup -> DEMO.

Shift key

This short cut is only available in the main menu. Press the ENTER button, until a small arrow starts blinking in the display. Memory 1 or memory 2 calls up one of two factory settings.

DMX control

DMX mode

The L7 offers, depending on the model, up to 15 DMX modes. Use the 8 bit modes with basic DMX controllers like dimmer consoles. The most common modes for operation via DMX are mode 1 and mode 2.

ARRI recommends the use of the 16 bit modes in combination with DMX controllers supporting 16 bit resolution to obtain best results. The high resolution provides smooth dimming and precise color adjustments.

The coarse/fine modes utilize two DMX channels for most parameters and provide higher resolution compared to the 8 bit modes in combination with DMX controllers that do not support 16 bit resolution. One channel sets the coarse value of the function which is divided in 256 increments using the fine channel.

The setting can be changed any time using the rotary knobs of the fixture menu.

White and RGBW

This mode provides control of intensity, color temperature, +/- green and individual channels for controlling the red, green, blue and white color.

White

Simple white-only mode. It is used when the number of available channels of the DMX controller is very limited. It provides control of intensity, color temperature and +/- green.

White & HSI

Provides control of intensity, color temperature, +/- green, hue and saturation (HSI = hue, saturation, intensity). In HSI mode the color and intensity is very even over the fixtures as it is controlled using color algorithms which take the tolerances of the light engines into account during calculation.

RGBW

Simple mode for controlling the overall intensity and the red, green, blue and white intensity when only a limited number of DMX channels is available.

HSI

Simple mode for controlling hue, saturation and intensity when only a limited number of DMX channels is available.

Please find a detailed description of all modes in chapter "DMX Protocol" on page 31.

Note: Depending on the selected DMX mode the channels required for each product should be allocated in the DMX controller to provide independent control of all products connected to the controller. Please allocate the maximum number of channels, which is 14 in DMX mode 6.

DMX data link

For controlling the L7 via DMX you need a DMX data link.

The L7 has 5-pin locking XLR sockets for DMX and RDM data input and output. The default pin-out of both sockets is:

Pin 1 = Shield

Pin 2 = Data - (cold)

Pin 3 = Data + (hot).

Pins 4 and 5 are not used by the L7 but are bridged between input and output sockets. These pins can therefore be used as a pass-through connection for an additional data signal if required.

Pin 4 = Data - (cold)

Pin 5 = Data + (hot).

You must not connect more than 32 products per data link. Depending on the channel requirements the address space of a data link (512 channels) may not be enough to control all products connected. You may set more than one product to identical DMX addresses to obtain identical behavior. For independent control every product needs to be assigned an individual address range.

If you need to control more products individual, you need to set up additional DMX data links.

Tips for a reliable data transmission

- Use shielded twisted-pair cable designed for RS-485 devices or CAT 6 network cables: standard microphone cable cannot transmit control data reliably over long runs. 24 AWG cable is suitable for runs up to 300 meters (1000 ft.). Heavier gauge cable and/or an amplifier is recommended for longer runs.
- To split the data link, use a DMX splitter. Use an RDM compatible splitter when you use the RDM functionality.
- Install a DMX termination plug on the last product of every DMX data link. Terminate the DMX data link on both ends, when you use the RDM functionality. Ask your system specialist for details.

To connect the data link

- Connect the DMX data output from the controller to the data input (male XLR) of the L7.
- Run the data link from the data output (female XLR) to the data input of the next product.
- Terminate the data link by connecting a 120 Ohm, 0.25 Watt resistor between the data 1 hot (+) and cold (-) conductors (and between data 2 hot and cold if used) at the data output of the last product on the link.

Fixture Menu

Note: The small, horizontal arrow in the displays indicates sub-menus. Press the ENTER button to access the sub-menus.

Level 1	Level 2	Level 3	Level 4	Description (Default = bold)
Intensity				Displays the recent intensity level when turning the dimmer knob in %
CCT				Only in CCT mode: Displays the recent color temperature when turning the CCT/HUE knob in K
HUE				Only in HUE mode (only L7-C): Displays the recent hue when turning the CCT/HUE knob in ° (0-360°)
GRN				Only in CCT mode: Displays the recent green / magenta value when turning the GRN/SAT knob in %
SAT				Only in HUE mode (only L7-C): Displays the recent saturation when turning the GRN/SAT knob in %
STATUS	OK			Product ready for operation, no errors OR Error
	ERROR			
	XX.X°C			Recent temperature of the light engine
	HOUR		XXXX t	Hours of operation
	DMX V		X.X	Version of the DMX protocol
	SW			Firmware version

Level 1	Level 2	Level 3	Level 4	Description (Default = bold)
SETUP	DMX	PROT	P.001...P.015	Set the DMX mode
		LSIG	HOLD	The DMX values are held when DMX signal is lost
			BOU	Product douses when DMX signal is lost
			H2MF	Product douses 2 min after DMX signal is lost
	CHAN	1...512[-Mode]	Set the DMX start address. Max. start address = 512 - channels used by the DMX mode chosen.	
	FACT	NO	Do not load the factory defaults	
		YES	Load the factory defaults	
	DEMO	ON	Activate the demo sequence (see page 24)	
		OFF	De-activate the demo sequence	
	INDC	ON	The status indicators and the illumination of the display remain ON	
		OFF	The status indicators and the illumination of the display switch OFF	
	FAN	OFF	Fan AUS	
		LOW	Fan mode LOW	
		HI	Fan mode HI	
		ALOW	Fan mode ALOW	
		AHI	Fan mode AHI	
		VARI	Fan mode VARI	
PASS		Fan mode PASS		
HI45 (only L7 Active)	Fan mode HI45			

RDM commands

Please find a complete overview of all supported RDM commands for free download on the ARRI web site www.arri.com.

ARRI Lighting Service Manager

Please find information about the features and the functionality of the ARRI Lighting Service Manager in the user manual for the ARRI Lighting Service Manager, which can be downloaded with the ARRI Lighting Service Manager software-bundle from the ARRI web site www.arri.com/lightingsoftware free of charge.

Error Messages

Code	Error	Remedy
E.003	Controller over temperature. STATUS lit up red.	Let the product cool down. The STATUS indicator changes to green when the product has cooled down. Turn the dimmer knob to „0“ or send an intensity value „0“ via DMX to activate the light engine again.
E.004	Light engine over temperature	See E.003
E.005	Power supply over temperature	See E.003
E.006	Calibration data of light engine faulty or EEPROM error.	WARNING: Loss of calibration data. This error can only be fixed by re-calibrating the light engine. Please contact the ARRI service.
E.007	Invalid PWM value calculation	Notice: The product can be used on. This message is more a notification than an error.
E.008	Invalid values during calculation	See E.007
E.009	Invalid values during calculation	See E.007
E.010	Fan error. The fan speed deviates or the fan doesn't run at all.	Set the fan to LOW or HI and see if it starts rotating, in order to determine if there is an electrical malfunction. All mechanical tests or repairs may only be carried out by a trained service technician.
From SW version 1.72.0		
E.011	Fixture menu module not be detected.	If the fixture menu is working, error E.011 can be ignored. However, if the fixture menu remains dark (no LED lights up) we recommend to contact the ARRI service. They can then carry out detailed analyses.
E.012	Temperature sensor(s) are defective or deviation within NTC values too high.	One or more temperature sensors are defective or the deviation within the individual NTCs or BNTCs exceeds the variation tolerance of 12° C / 54° F. Check the error log (LSeries Manager) to see which temperature sensors are affected. Contact the ARRI service.

DMX Protocol

L7-TT (Tungsten Tuneable)

Overview

8 bit, 1 channel per function	16 bit, 2 channels per function	Coarse / fine, 2 channels per function
DMX mode 1*	DMX mode 2	DMX mode 3

* = Factory default

GN saturation - average equivalents.

Setting	Rosco#	Setting	Rosco#
Full -Green	3308	Full +Green	3304
1/2 -Green	3313	1/2 +Green	3315
1/4 -Green	3314	1/4 +Green	3316
1/8 -Green	3318	1/8 +Green	3317

Mode 1: 8 bit resolution per function

Channel	Value	Percent	Function
1	0-255	0-100	Dimmer closed → open
2	0-255	0-100	Color temperature CCT 2.600 K → 3.600 K
3	0-10 11-20 21-119 120-145 146-244 245-255	0-4 5-8 8-46 47-57 57-96 96-100	GN saturation neutral / no effect full minus green -99% → -1% neutral / no effect 1% → 99% full plus green

Mode 2: 16 bit resolution per function

Channel	Value	Percent	Function
1	HI	0-65535	Dimmer closed → open
2	LO		
3	HI	0-65535	Color temperature CCT 2.600 K → 3.600 K
4	LO		
5	HI	0-5.000 5.001-10.000 10.001-29.999 30.000-40.000	GN saturation neutral / no effect full minus green -99% → -1% neutral / no effect 1% → 99% full plus green
6	LO	40.001-59.999 60.000-65.535	

Mode 3: Coarse / fine channel per function

Each of the 256 coarse steps is divided in 256 fine steps. Use this mode when your lighting control desk does not support true 16 bit resolution.

Channel	Value	Percent	Function
1	0-255	0-100	Dimmer coarse closed → open
2	0-255	0-100	Dimmer fine
3	0-255	0-100	Color temperature coarse 2.600 K → 3.600 K
4	0-255	0-100	Color temperature fine
5	0-10 11-20 21-119 120-145 146-244 245-255	0-4 5-8 8-46 47-57 57-96 96-100	GN saturation neutral / no effect full minus green -99% → -1% neutral / no effect 1% → 99% full plus green

L7-DT (Daylight Tuneable)**Overview**

8 bit, 1 channel per function	16 bit, 2 channels per function	Coarse / fine, 2 channels per function
DMX mode 1*	DMX mode 2	DMX mode 3

* = Factory default

GN saturation - average equivalents.

Setting	Rosco#	Setting	Rosco#
Full -Green	3308	Full +Green	3304
1/2 -Green	3313	1/2 +Green	3315
1/4 -Green	3314	1/4 +Green	3316
1/8 -Green	3318	1/8 +Green	3317

Mode 1: 8 bit resolution per function

Channel	Value	Percent	Function
1	0-255	0-100	Dimmer closed → open
2	0-255	0-100	Color temperature CCT 5.000 K → 6.500 K
3	0-10 11-20 21-119 120-145 146-244 245-255	0-4 5-8 8-46 47-57 57-96 96-100	GN saturation neutral / no effect full minus green -99% → -1% neutral / no effect 1% → 99% full plus green

Mode 2: 16 bit resolution per function

Channel	Value	Percent	Function	
1	HI	0-65535	0-100	Dimmer closed → open
2	LO			
3	HI	0-65535	0-100	Color temperature CCT 5.000 K → 6.500 K
4	LO			
5	HI	0-5.000 5.001-10.000 10.001-29.999 30.000-40.000	0-7 8-15 16-46 46-61	GN saturation neutral / no effect full minus green -99% → -1% neutral / no effect 1% → 99% full plus green
6	LO	40.001-59.999 60.000-65.535	61-92 92-100	

Mode 3: Coarse / fine channel per function

Each of the 256 coarse steps is divided in 256 fine steps. Use this mode when your lighting control desk does not support true 16 bit resolution.

Channel	Value	Percent	Function
1	0-255	0-100	Dimmer coarse closed → open
2	0-255	0-100	Dimmer fine
3	0-255	0-100	Color temperature coarse 5.000 K → 6.500 K
4	0-255	0-100	Color temperature fine
5	0-10 11-20 21-119 120-145 146-244 245-255	0-4 5-8 8-46 47-57 57-96 96-100	GN saturation neutral / no effect full minus green -99% → -1% neutral / no effect 1% → 99% full plus green

L7-C

Overview

8 bit, 1 channel per function	16 bit, 2 channels per function	Coarse/fine, 1-2 channels per function
DMX mode 1* White & RGBW	DMX mode 6 White & RGBW	DMX mode 11 White & RGBW
DMX mode 2 White	DMX mode 7 White	DMX mode 12 White
DMX mode 3 White & HSI	DMX mode 8 White & HSI	DMX mode 13 White & HSI
DMX mode 4 RGBW	DMX mode 9 RGBW	DMX mode 14 RGBW
DMX mode 5 HSI	DMX mode 10 HSI	DMX mode 15 HSI

* = Factory default

GN saturation - average equivalents.

Setting	Rosco#	Setting	Rosco#
Full -Green	3308	Full +Green	3304
1/2 -Green	3313	1/2 +Green	3315
1/4 -Green	3314	1/4 +Green	3316
1/8 -Green	3318	1/8 +Green	3317

Mode 1: White & RGBW, 8 bit resolution per function

Channel	Value	Percent	Function
1	0-255	0-100	Dimmer closed → open
2	0-255	0-100	Color temperature CCT 2.800 K → 10.000 K
3	0-10 11-20 21-119 120-145 146-244 245-255	0-4 5-8 8-46 47-57 57-96 96-100	GN saturation neutral / no effect full minus green -99% → -1% neutral / no effect 1% → 99% full plus green
4	0-255	0-100	Xfade to color White → RGBW color
5	0-255	0-100	Intensity red 0% → 100%
6	0-255	0-100	Intensity green 0% → 100%
7	0-255	0-100	Intensity blue 0% → 100%
8	0-255	0-100	Intensity white 0% → 100%

Mode 2: White, 8 bit resolution per function

Channel	Value	Percent	Function
1	0-255	0-100	Dimmer closed → open
2	0-255	0-100	Color temperature CCT 2.800 K → 10.000 K
3	0-10 11-20 21-119 120-145 146-244 245-255	0-4 5-8 8-46 47-57 57-96 96-100	GN saturation neutral / no effect full minus green -99% → -1% neutral / no effect 1% → 99% full plus green

Mode 3: White & HSI, 8 bit resolution per function

Channel	Value	Percent	Function
1	0-255	0-100	Dimmer closed → open
2	0-255	0-100	Color temperature CCT 2.800 K → 10.000 K
3	0-10 11-20 21-119 120-145 146-244 245-255	0-4 5-8 8-46 47-57 57-96 96-100	GN saturation neutral / no effect full minus green -99% → -1% neutral / no effect 1% → 99% full plus green
4	0-255	0-100	Xfade to color White → RGBW color
5	0-255	0-100	Hue 0° → 360°
6	0-255	0-100	Saturation 0 → full saturated

Mode 4: RGBW, 8 bit resolution per function

Channel	Value	Percent	Function
1	0-255	0-100	Dimmer closed → open
2	0-255	0-100	Intensity red 0% → 100%
3	0-255	0-100	Intensity green 0% → 100%
4	0-255	0-100	Intensity blue 0% → 100%
5	0-255	0-100	Intensity white 0% → 100%

Mode 5: HSI, 8 bit resolution per function

Channel	Value	Percent	Function
1	0-255	0-100	Dimmer closed → open
2	0-255	0-100	Hue 0° → 360°
3	0-255	0-100	Saturation 0 → full saturated

Mode 6: White & RGBW, 16 bit resolution per function

Channel	Value	Percent	Function
1	HI	0-65535	Dimmer closed → open
2	LO		
3	HI	0-65.535	Color temperature CCT 2.800 K → 10.000 K
4	LO		
5	HI	0-5.000 5.001-10.000 10.001-29.999 30.000-40.000 40.001-59.999 60.000-65.535	GN saturation neutral / no effect full minus green -99% → -1% neutral / no effect 1% → 99% full plus green
6	LO		
7	HI	0-65.535	Xfade to color White → RGBW color
8	LO		
9	HI	0-65.535	Intensity red 0% → 100%
10	LO		
11	HI	0-65.535	Intensity green 0% → 100%
12	LO		
13	HI	0-65.535	Intensity blue 0% → 100%
14	LO		
15	HI	0-65.535	Intensity white 0% → 100%
16	LO		

Mode 7: White, 16 bit resolution per function

Channel		Value	Percent	Function
1	HI	0-65535	0-100	Dimmer closed → open
2	LO			
3	HI	0-65.535	0-100	Color temperature CCT 2.800 K → 10.000 K
4	LO			
5	HI	0-5.000 5.001-10.000 10.001-29.999 30.000-40.000	0-7 8-15 16-46 46-61	GN saturation neutral / no effect full minus green -99% → -1% neutral / no effect 1% → 99% full plus green
6	LO	40.001-59.999 60.000-65.535	61-92 92-100	

Mode 8: White & HSI, 16 bit resolution per function

Channel		Value	Percent	Function
1	HI	0-65535	0-100	Dimmer closed → open
2	LO			
3	HI	0-65.535	0-100	Color temperature CCT 2.800 K → 10.000 K
4	LO			
5	HI	0-5.000 5.001-10.000 10.001-29.999 30.000-40.000	0-7 8-15 16-46 46-61	GN saturation neutral / no effect full minus green -99% → -1% neutral / no effect 1% → 99% full plus green
6	LO	40.001-59.999 60.000-65.535	61-92 92-100	
7	HI	0-65.535	0-100	Xfade to color White → RGBW color
8	LO			
9	HI	0-65.535	0-100	Hue 0° → 360°
10	LO			
11	HI	0-65.535	0-100	Saturation 0 → full saturated
12	LO			

Mode 9: RGBW, 16 bit resolution per function

Channel		Value	Percent	Function
1	HI	0-65535	0-100	Dimmer closed → open
2	LO			
3	HI	0-65.535	0-100	Intensity red 0% → 100%
4	LO			
5	HI	0-65.535	0-100	Intensity green 0% → 100%
6	LO			
7	HI	0-65.535	0-100	Intensity blue 0% → 100%
8	LO			
9	HI	0-65.535	0-100	Intensity white 0% → 100%
10	LO			

Mode 10: HSI, 16 bit resolution per function

Channel		Value	Percent	Function
1	HI	0-65535	0-100	Dimmer closed → open
2	LO			
3	HI	0-65.535	0-100	Hue 0° → 360°
4	LO			
5	HI	0-65.535	0-100	Saturation 0 → full saturated
6	LO			

Mode 11: White & RGBW, Coarse/fine per function

Channel	Value	Percent	Function
1	0-255	0-100	Dimmer coarse closed → open
2	0-255	0-100	Dimmer fine
3	0-255	0-100	Color temperature CCT coarse 2.800 K → 10.000 K
4	0-255	0-100	Color temperature fine
5	0-10 11-20 21-119 120-145 146-244 245-255	0-4 5-8 8-46 47-57 57-96 96-100	GN saturation neutral / no effect full minus green -99% → -1% neutral / no effect 1% → 99% full plus green
6	0-255	0-100	Xfade to color White → RGBW color
7	0-255	0-100	Intensity red coarse 0% → 100%
8	0-255	0-100	Red fine
9	0-255	0-100	Intensity green coarse 0% → 100%
10	0-255	0-100	Green fine
11	0-255	0-100	Intensity blue coarse 0% → 100%
12	0-255	0-100	Blue fine
13	0-255	0-100	Intensity white coarse 0% → 100%
14	0-255	0-100	White fine

Mode 12: White, Coarse / fine channel per function

Channel	Value	Percent	Function
1	0-255	0-100	Dimmer coarse closed → open
2	0-255	0-100	Dimmer fine
3	0-255	0-100	Color temperature CCT coarse 2.800 K → 10.000 K
4	0-255	0-100	Color temperature fine
5	0-10 11-20 21-119 120-145 146-244 245-255	0-4 5-8 8-46 47-57 57-96 96-100	GN saturation neutral / no effect full minus green -99% → -1% neutral / no effect 1% → 99% full plus green

Mode 13: White & HSI, Coarse / fine channel per function

Channel	Value	Percent	Function
1	0-255	0-100	Dimmer coarse closed → open
2	0-255	0-100	Dimmer fine
3	0-255	0-100	Color temperature CCT coarse 2.800 K → 10.000 K
4	0-255	0-100	Color temperature fine
5	0-10 11-20 21-119 120-145 146-244 245-255	0-4 5-8 8-46 47-57 57-96 96-100	GN saturation neutral / no effect full minus green -99% → -1% neutral / no effect 1% → 99% full plus green
6	0-255	0-100	Xfade to color White → RGBW color
7	0-255	0-100	Hue coarse 0 → 360°
8	0-255	0-100	Hue fine
9	0-255	0-100	Saturation coarse 0 → full saturated
10	0-255	0-100	Saturation fine

Mode 14: RGBW, Coarse / fine channel per function

Channel	Value	Percent	Function
1	0-255	0-100	Dimmer coarse closed → open
2	0-255	0-100	Dimmer fine
3	0-255	0-100	Intensity red coarse 0% → 100%
4	0-255	0-100	Red fine
5	0-255	0-100	Intensity green coarse 0% → 100%
6	0-255	0-100	Green fine
7	0-255	0-100	Intensity blue coarse 0% → 100%
8	0-255	0-100	Blue fine
9	0-255	0-100	Intensity white coarse 0% → 100%
10	0-255	0-100	White fine

Mode 15: HSI, Coarse / fine channel per function

Channel	Value	Percent	Function
1	0-255	0-100	Dimmer coarse closed → open
2	0-255	0-100	Dimmer fine
3	0-255	0-100	Hue coarse 0 → 360°
4	0-255	0-100	Hue fine
5	0-255	0-100	Saturation coarse 0 → full saturated
6	0-255	0-100	Saturation fine

Overview of typical CCT values as DMX values

CCT-Value	DMX-Value (8 bit)			DMX-Value (16 bit)		
	TT	DT	C	TT	DT	C
L7-	TT	DT	C	TT	DT	C
3.200 K	153	--	14	39.321	--	3.670
5.600 K	--	102	99	--	26.214	25.493
6.000 K	--	170	113	--	43.712	29.098
6.500 K	--	100%	131	--	65.535	33.685

To calculate CCT values in DMX % and vice versa

Use the following formulas to transform CCT values in DMX % values and vice versa:

$$CCT_{\text{Value}} = \frac{(CCT_{\text{max}} - CCT_{\text{min}}) \times DMX_{\text{in percent}}}{100} + CCT_{\text{min}}$$

$$DMX_{\text{in percent}} = \frac{CCT_{\text{recent}} - CCT_{\text{min}}}{CCT_{\text{max}} - CCT_{\text{min}}} \times 100$$

CCT values for the L7 models:

L7-TT (Tungsten Tuneable)

$$CCT_{\text{min}} = 2.600 \text{ K}$$

$$CCT_{\text{max}} = 3.600 \text{ K}$$

L7-DT (Daylight Tuneable)

$$CCT_{\text{min}} = 5.000 \text{ K}$$

$$CCT_{\text{max}} = 6.500 \text{ K}$$

L7-C

$$CCT_{\text{min}} = 2.800 \text{ K}$$

$$CCT_{\text{max}} = 10.000 \text{ K}$$

Specification

Physical

Dimension	See dimensional drawings on page 3
Weight (active, manual version, w/o accessories)	18 lbs (8.2 kg)
Weight (active, P.O. version, w/o accessories)	22.0 lbs (10.0 kg)

Light source

Type	ARRI LED Light Engine
Typ. LED lifetime L70	50.000 h
White light	2.800 K - 10.000 K (L7-C)
	2.600 K - 3.600 K (L7-TT)
	5.000 K - 6.500 K (L7-DT)
Colored light	RGBW color mixing (only L7-C)
Color rendering index	typ. CRI >94
Green/Magenta saturation	+/- 1 (full green to full magenta)

Optical path

Type	Fresnel, focussable
Lens diameter	175 mm / 7"
Half peak angle	15° - 50°

Dynamic functions

Dimmer	electronic, 0 - 100%
Color mixing	RGBW color mixing
	(Hue and saturation, only L7-C)

Control and Programming

DMX channels	3-14 channels, depending on type and mode
Setting and addressing	Fixture menu, RDM, ALSM
DMX compliance	ESTA DMX 512A
RDM compliance	ESTA DMX 512A
Firmware update	USB interface and ALSM

Construction

Color	Blue/silver or black
Housing	Composite housing
Protection rating	IP 20
Protection class	I

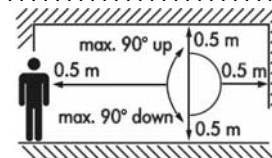

Installation

Mounting	28 mm spigot
Orientation	+/- 90°
Minimum clearance around fixture	0,5 m (19.7 in.)
Minimum view distance to light aperture	0,5 m (19.7 in.)

Connectors

Power input	Neutrik® PowerCON® True1
DMX and RDM data in/ through	5-pin, locking XLR connector
USB connector	Mini-USB-A

Electrical

AC power 100 - 240 V ~, 50 - 60 Hz (nom.)
 Power supply Auto-sensing switching-mode power supply

Typical Power

230 V, 50 Hz. 220 W
 cos ϕ > 0.9
 Measurements made at nominal voltage with all LEDs at full intensity.
 Allow for a deviation of +/- 10%

Noise emission

Ambient temperature = 35° C (95° F). < 20dB(A)
 Ambient temperature = 45° C (113° F). < 30dB(A)

Thermal

Minimum ambient temperature (t_a). -20° C / -4° F
 Maximum ambient temperature (t_a) +45° C / 113° F
 Cooling Silent, temperature-controlled fan cooling

Approvals**RISK GROUP 1 - No Risk**

No photobiological hazard under normal behavioral limitations.

CE, UKCA, CB, ENEC, cNRTLus, FCC, PSE

This Device complies with part 15 of the FCC Rules.

Operation is subject to the following two conditions:

- (1) This device may not cause harmful interference, and
- (2) this device must accept any interference received, including interference that may cause undesired operation.

Included items

28 mm spigot
 Short instruction
 Power input cable

Specification subject to change without notice. For the latest product specification including photometric data, see www.arri.com

In case of technical problems, please visit us at www.arri.com, to find the next ARRI service center.

www.arri.com

ARRI 