

ARRI NEWS

IBC ISSUE 2014



AMIRA

Major software update and ProRes UHD upgrade option



L5 LED FRESNEL

Portable, tuneable L5 lamphead expands the L-Series



PRORES 3.2K FOR ALEXA

New recording format simplifies UHD deliverables



VERSATILE LENS DATA

Electronic Control System for any lens and any camera

EDITORIAL

DEAR FRIENDS AND COLLEAGUES

Within only a few months of being released, AMIRA has been used on an amazing variety of productions all over the world, from social documentaries and wildlife films to commercials and branded content. Already gaining positive feedback after a successful first presentation at BIRTV in Beijing, AMIRA's UHD option will widen these application areas still further, allowing it to be used on productions requiring a UHD workflow direct from camera. ALEXA is benefiting from the new ProRes 3.2K format, ensuring that it too can continue to meet the distribution needs of any production.



With interest in anamorphic cinematography building (we have two articles featuring our Master Anamorphic lenses in this issue), ALEXA's unique 4:3 sensor means it remains the camera of choice. Its exceptional dynamic range is also becoming increasingly relevant in an industry gradually realizing that high dynamic range has an even greater impact on viewing experience than spatial resolution. Through our work helping to promote



Dolby® Vision™ technology, we are spreading the message that for capture as well as display, you need better pixels not just more pixels.

On the lighting side our L-Series of LED Fresnels is growing with the release of the compact L5. Meanwhile our M-Series of daylight fixtures is building strong support worldwide; we have two user stories in these pages, one from the U.S. and the other from Japan.

Also from Japan comes our restoration story, with Tokyo Laboratory using ARRISCAN Archive Technology to preserve and restore *Godzilla* films dating back to 1954.

Visit arri.com/ibc2014 for day-by-day news and videos throughout IBC. If you're in Amsterdam for the show, don't miss our various presentations and seminars.

Dr. Martin Prillmann

Franz Kraus

CONTENTS

CAMERA

- 4 Three ALEXA XT camera models on *Unbroken*
- 6 New ProRes 3.2K format for UHD TV with ALEXA
- 8 ALEXA Software Update Packet (SUP) 10.0
- 16 Documentary for Vodafone captured with AMIRA
- 18 AMIRA to offer direct ProRes UHD output
- 20 First major software update for AMIRA: SUP 1.1
- 22 DP Bradford Young on the Master Anamorphics
- 24 Lens data with the Electronic Control System
- 30 Ron Fortunato, ASC, uses ALEXA on *Elementary*
- 32 SMB-1 tilting matte box in testing for sci-fi film
- 34 Master Anamorphics give Ford spots a movie look
- 38 ARRI supports German camera museum

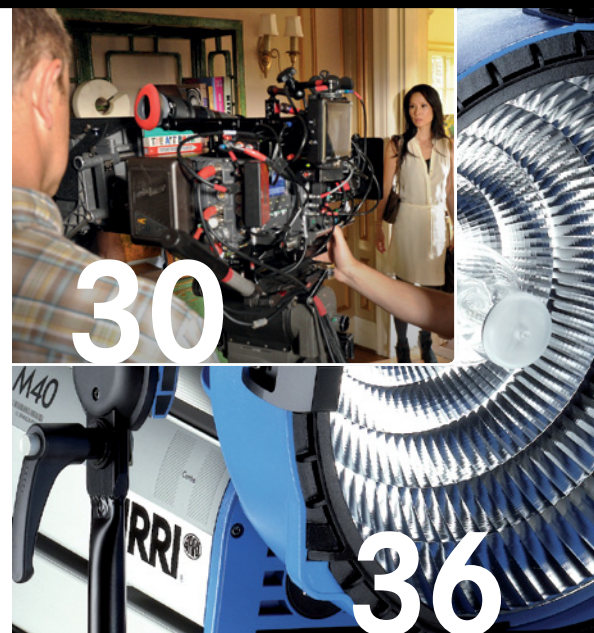



LIGHTING

- 10** Hit TV series *Fargo* relies on the M-Series
- 26** L-Series lights equip German news studio
- 28** Portable L5 LED Fresnel expands L-Series
- 36** ARRI daylight fixtures light up cherry blossoms in Japan

DI SYSTEMS

- 12** Classic *Godzilla* films restored with the ARRISCAN

CONTACTS

38



UNBROKEN

Roger Deakins, CBE, ASC, BSC, records ARRIRAW with a range of ALEXA XT cameras on Angelina Jolie's dramatic new war movie

Directed by Angelina Jolie and based on Laura Hillenbrand's book, *Unbroken* tells the remarkable true story of Louis Zamperini, an American distance runner who competed at the 1936 Berlin Olympics before enlisting in the U.S. Army Air Forces during World War II. When his B-24 crashed into the Pacific Ocean, Zamperini survived 47 days adrift on a lifeboat, only to be captured by the Japanese and subjected to brutal mistreatment in prisoner-of-war camps. For cinematographer Roger Deakins, CBE, ASC, BSC, who has used ALEXAs on every digital film he has shot, *Unbroken* provided an opportunity to try out the latest generation of ALEXA XT cameras, combining them with ARRI/ZEISS Master Prime lenses.

What kind of a look did you and Angelina want for this epic narrative?

The film is epic in some ways, but it is also intensely personal. The most important decision to be made was where to shoot the film, because we needed such specific and



DP Roger Deakins, CBE, ASC, BSC



varied settings. In the end we were led to shoot in Australia, specifically in and around Sydney and in various parts of Queensland. The look of the film developed as Angie, our production designer Jon Hutman and I scouted and talked through the script, but key to it was that this was a personal story and we wanted the audience to feel connected to the characters.

Unbroken was your introduction to the ALEXA XT cameras. Were you pleased with this evolution of the ALEXA camera system?

The ALEXA XT is a really wonderful tool and we had absolutely no issues with the cameras. I especially liked the internal NDs, as they were a real bonus for us in the bright sunlight of Australia. The ALEXA XT Studio has its own internal ND filter system, which was also of great value.

There must have been situations involving extreme highlights and contrast; did the ALEXA image hold up?

I had no expectation of the image not holding up, as I had shot in similar conditions for *Skyfall*. In fact on *Skyfall* I felt I had used the ALEXA in such a variety of conditions that I had absolutely no concerns about using the camera on *Unbroken*. When I was first talking with Angie we were considering film, but after shooting tests with the ALEXA and realizing the amount of effects work we would be doing in post, she was very comfortable with the choice of the ALEXA.

Which ALEXA XT models did you have?

We used an XT Studio, an XT Plus and an XT M camera. I like the optical viewfinder that the XT Studio has when I am working off

the dolly or on a tripod. When I am on a remote head, which is something I do quite a lot on any film but which was vital for scenes on the water and on the running track, then I will use the XT Plus camera.

We had a full-size mock-up of a B-24 plane, which we used in two expansive sequences. Although the mock-up was 75 feet in length, the actual working space was very small, so we used an XT M camera mounted on a Micro Scorpio remote head. This allowed us to add a fluid movement to the camera and to follow the action in a way that would have been pretty-well impossible with a conventional rig.

You've been shooting with the ALEXA Open Gate mode on your new film *Sicario*. Has it proved to be a useful feature?

I have been loving shooting Open Gate with the ALEXA. I compare it to shooting Super 35 mm film, as it has a similar effect on my lens choice. Utilizing those extra few pixels really does make a difference. Not that I have any complaints about the regular ARRIRAW image, but you do see some extra subtle crispness of detail with Open Gate, especially on a wide landscape shot.





CAPTURE WITH ALEXA, DELIVER ANYTHING

Recording formats including the new ProRes 3.2K make ALEXA's best overall image quality and best overall production value available to projects requiring UHD, 4K or HDR deliverables

ALEXA IS FUTURE-PROOF

The majority of digital film and television productions continue to capture, postproduce and distribute in HD or 2K, formats for which ALEXA provides an unmatched solution. Widespread adoption of UHD/4K post workflows, as well as availability of UHD displays in consumer homes and 4K projection in theaters is at least one to two years away – even in the most progressive markets. However, some film and program

makers are already concerned about protecting their work for future developments. The ongoing debate surrounding high dynamic range (HDR) displays, which have an even greater effect on viewing experience than higher spatial resolution, only adds to these concerns.

Designed from the outset to be adaptable and future-proof, ALEXA can easily accommodate productions that choose to follow a UHD or 4K workflow. The camera's stellar overall image quality in combination

with ProRes 3.2K (due for release as a software update in early 2015) and ARRIRAW Open Gate (released earlier this year) allows for simple up-sampling to UHD or 4K in a quality at least as good as other contenders. And because of their unequalled exposure latitude and highlight handling, ALEXA images are already uniquely HDR-compatible. Put simply, ALEXA remains the safest available capture tool for asset longevity, no matter what future standards come to fruition.

ALEXA IS FUTURE-PROOF...

...THROUGH MULTIPLE RECORDING FORMATS

- HD TV > ProRes HD (16:9) or DNxHD (16:9)
- 2K feature > ProRes 2K (16:9 or 4:3) or ARRIRAW (16:9 or 4:3)
- UHD TV > ProRes 3.2K (16:9)
- 4K feature > ARRIRAW (16:9, 4:3 or Open Gate)

...THROUGH MULTIPLE SENSOR MODES

- Spherical productions > 16:9 ProRes, 16:9 DNxHD, 16:9 ARRIRAW, Open Gate ARRIRAW
- Anamorphic productions > 4:3 ProRes, 4:3 ARRIRAW

...THROUGH HIGH DYNAMIC RANGE IMAGES

- Wide exposure latitude
- Extremely low noise floor
- Extended, clean highlights
- Natural colors, even when over/underexposed



“ProRes 3.2K gives ALEXA customers greater workflow flexibility than they've ever had before.”

Michael Cioni, founder and CEO of Light Iron

CAPTURE WITH ALEXA, DELIVER UHD FOR TELEVISION

For TV productions looking for a UHD deliverable, ALEXA XT cameras and ALEXA Classic cameras with the XR Module upgrade offer the new and cost-efficient ProRes 3.2K recording option. At data

rates far below uncompressed ARRIRAW, ProRes 3.2K provides the benefits of the well-established and efficient ProRes workflow. As an additional benefit, most lenses fully cover the 3.2K image circle

that results from the 16:9 ProRes 3.2K image. A straightforward up-sample from ProRes 3.2K using standard post tools delivers UHD images of the highest quality for broadband and broadcast.

CAPTURE WITH ALEXA, DELIVER 4K FOR FEATURE FILMS

Many high-profile movies have been shot in ARRIRAW 2.8K and up-sampled to a 4K DCP with spectacular results, an example being the last James Bond film, *Skyfall*. To further improve upon this option, ARRI introduced the ARRIRAW Open Gate recording format for ALEXA XT cameras. Open Gate records the full 3.4K

ALEXA XT sensor area for an optimal up-sample in post to a 4K DCP.

Open Gate has been enthusiastically received by the feature film industry and is in use on numerous productions already, including *Warcraft*, *San Andreas*, *Pixels*, *Goosebumps* and *Sicario*, the latest movie lensed by Roger Deakins, CBE, ASC, BSC.

Other feature films are shooting ARRIRAW 16:9 or ARRIRAW 4:3 and using Open Gate selectively for VFX shots, including *Terminator: Genesis*, *Fantastic 4*, *Agent 47* and *Deus Ex Machina*.

CAPTURE WITH ALEXA, PROTECT FOR HDR

Recent demonstrations of high dynamic range (HDR) displays have shown the extraordinary visual impact of increased dynamic range and sparked a debate over how and when they will be introduced. ARRI has been working with Dolby at major trade shows to help showcase Dolby® Vision™ display technology, which is capable of 100 times more brightness than a conventional TV. This has contributed to spreading awareness in the industry that dynamic range is an even more important factor than spatial resolution in creating a superior visual experience. Recognizing this, other companies such as Thomson,

Philips and the BBC are working on their own HDR solutions.

ALEXA's unrivalled exposure latitude, highlight handling and color science already result in images beyond the capabilities of current display technologies. The Dolby® Vision™ presentations have revealed how much better ALEXA images look when displayed with extended dynamic range, proving the enormous and as-yet untapped potential of ALEXA-originated material to be remastered for future HDR display standards.

ALEXA XT Recording Formats Overview

Sensor Mode	Recording Format	Format Settings
16:9	ProRes HD	422
		422 HQ 4444 4444 XQ
	ProRes 2K	422
		422 HQ 4444 4444 XQ
	ProRes 3.2K	422 422 HQ 4444 4444 XQ
DNxHD	145 220x 444	
	ARRIRAW	
4:3	ProRes 2K	422 422 HQ 4444 4444 XQ
		ARRIRAW
Open Gate	ARRIRAW	

SUP 10.0



ALEXA SUP 10.0

ALEXA's software updates reach double figures - like its nine predecessors, SUP 10.0 provides exciting new features and refinements

ALEXA's tenth software update will be released sometime in September this year, concluding an open beta that began in August. The many features in Software Update Packet (SUP) 10.0 have been chosen based on feedback from numerous set visits and a continual dialog with cinematographers, assistants, DITs, rental and post houses, and ARRI partners.

At its launch, ALEXA was promised to be a future-proof system and ARRI has been working hard to ensure that its feature set evolves with modern shooting practices and needs. It is the re-programmable FPGA (Field Programmable Gate Array) processors inside ALEXA cameras that have enabled them to be updated with functionality far beyond the original specifications.

The feedback keeps coming as digital production methods continue to evolve. Work is already underway on SUP 11.0, which will further improve the usefulness and flexibility of ALEXA cameras with features such as ProRes 3.2K and a checksum for ARRIRAW recording.

Apple ProRes 4444 XQ for ALEXA XT and XR

The new Apple ProRes 4444 XQ codec is the ideal choice for productions that are shooting for premium image quality, or are looking to take their color grading to extremes.

This new 12 bit RGB codec supports HD and 2K resolutions as well as 16:9 and 4:3 aspect ratios. Its data rate of 500 Mb/s (at 30 fps 1920 x 1080) is higher than ProRes 4444's 330 Mb/s, allowing a lower compression ratio that better preserves the superior tonal range of ALEXA's Log C signal.

Open Gate support for ALEXA XT M

The many movies that are already recording in the ARRIRAW Open Gate format with ALEXA XT, XT Plus and XT Studio cameras will now be able to do the same with the compact ALEXA XT M. Open Gate records the full size of the ALEXA sensor for an easy 4K up-sample or for repositioning, resizing and stabilizing in post.



ALEXA XT/XR ARRIRAW Sensor Modes

ARRIRAW 4:3 Cropped for ALEXA XT and XR

In order to reach 96 fps when shooting ARRIRAW 4:3 with anamorphic lenses, the new 'ARRIRAW 4:3 Cropped' mode reduces the width of the recorded image to 1.2:1, which is all that is needed to record the image produced by a 2x anamorphic lens.



ARRIRAW Open Gate (1.55:1)

3414 x 2198 photosites

ARRIRAW 4:3 Full (1.33:1)

2880 x 2160 photosites

ARRIRAW 4:3 Cropped (1.195:1)

2578 x 2160 photosites

ARRIRAW 16:9 (1.78:1)

2880 x 1620 photosites

ADDITIONAL NEW FEATURES FOR ALEXA CLASSIC, XT AND XR CAMERAS

180° image rotation

This allows Steadicam rigs to be flipped upside down for quick low mode shooting; it also rotates the image for the ARRI Ultra Wide Zoom UWZ 9.5-18/T2.9.

Faster regular/high speed switching

The time it takes ALEXA to switch from regular (0.75 - 60 fps) to high speed mode (60 - 120 fps) has been reduced to about 20 seconds.

Colored camera index letter

The camera index letter can be assigned a color (red, green, blue, yellow, black or white) to easily identify images from different cameras on monitors.

Support for SONY SxS PRO+ memory cards

ALEXAs now support recording ProRes or DNxHD to 64 GB and 128 GB SxS PRO+ memory cards.

Dimmable status information

The status information overlay available on EVF and MON OUT can now be dimmed for low light scenes.

'Lens Squeeze Factor' metadata field

This new metadata field allows the manual entry of a 'Lens Squeeze Factor' so post software can automatically de-squeeze anamorphic images.

REC OUT = clean MON OUT

More recording modes now support two independent HD-SDI outputs, allowing a clean Log C signal on REC OUT, while a Rec 709 signal with overlays and an optional ARRI Look File can be output on MON OUT.

Monochrome status icons

The rectangular status icons to the left and right of the image are now monochrome, which is less distracting when color grading on the set.

Independent peaking setting for playback

Peaking on the MON OUT and EVF during playback can be set independently from peaking during recording. The factory default is 'Peaking during playback = off'.



F A R G O



Photos: Matthias Clamer/FX
©2014, FX Networks. All rights reserved.

LIGHTING FARGO

Matthew J. Lloyd, CSC, relies on ARRI M-Series lampheads while shooting the opening episodes of hit TV series Fargo

Inspired by the Coen brothers' 1996 film of the same name, *Fargo* is an Emmy® Award-winning U.S. comedy drama series about a hapless insurance salesman in northern Minnesota who gets drawn into a world of violence and crime. Director Adam Bernstein and cinematographer Matthew J. Lloyd, CSC, worked together on the first two episodes, setting the visual tone for the rest of the season. Lloyd spoke with ARRI News about how daylight fixtures from ARRI's M-Series helped him create the signature look of the show.

How did you and Adam set about crafting a look for *Fargo*?

The look the Coens set out in the movie was an important reference, but mainly as a stepping stone to move us into a more contemporary aesthetic, because Adam had a vision for the show that was a little bit darker. Underlying everything was the snowy

bleakness that exists in the movie and would obviously have to exist in the show as well. We wanted to see as much of this world as possible and to set everything against that overcast backdrop.

What lighting challenges did the consistently overcast look present?

Ultimately it became a fairly traditional exposure question of how to balance our rather dim interior locations against the atomic white backgrounds outside. We decided early on not to have windows clipping and highlights that were out of range, but to maintain detail throughout the image. We also didn't ever want to see the sun, which in Alberta, Canada is not an easy proposition. You end up with these massive setups where you're shooting out of windows and using a lot of bounced light, always having to match to existing daylight, so HMI became the only way to go.



DP Matthew J. Lloyd, CSC

Can you give an example of how you used M-Series fixtures for these setups?

There was a location where I ran 80 feet of Ultrabounce all the way down a building to block the sun and create a surface for bounce light. By spreading six or seven M40s down the building I got enough punch to achieve the level I wanted inside. Being small and lightweight, the M40 was really easy to work with on location, allowing us to light the broad



surface area that we needed to create our overcast look. In general the smaller M-Series units were crucial to our lighting approach on *Fargo*; they were highly controllable, easy to move around and were totally reliable, even at -30°C . Anything else would have involved way more logistics and heavy rigging.

You also had the M18; was that used for interior lighting?

I usually avoided having a lot of equipment on the ground, but I would sometimes use an M18 inside, bounced into some poly and pushed through a frame with a grid on it. Most of the lighting on this

show was bounced or diffused, which is another great thing about the M-Series: they're small HMIs but they have so much punch that you can use these diffusion rigs to create incredibly soft sources inside. The reflector design lets you control things in a sophisticated way and opens up a lot of creative opportunities.

Have you tried any other M-Series fixtures since *Fargo*?

Right now I'm doing the pilot of a Marvel series called *Daredevil* and the two M90s I've got on the truck are my biggest fixtures; I'm not even carrying a 12 kW or 18 kW. The

fact that it can go on a combo stand and one guy can move it makes the M90 a total game-changer. I'm able to create direct sunlight wherever we are by putting my two M90s up on a lift or a scissor, which is relatively quick and easy to do. You can literally turn that light on and pick out a water tower six blocks away – the throw is incredible.



Photo: Chris Large/FX





GODZILLA

REVIVING THE KING OF MONSTERS

Godzilla TM&© 1954 TOHO CO., LTD

Tokyo Laboratory uses the ARRISCAN to restore and repurpose historic Godzilla films for 4K distribution

This year marks the 60th anniversary of Ishirō Honda's 1954 film *Godzilla*, which first introduced Japan's giant, city-destroying monster to movie audiences. 2014 also saw a new incarnation of the now world-famous creature, in the identically-titled American blockbuster directed by Gareth Edwards.

To help celebrate the anniversary, Japanese film lab and digital postproduction facility Tokyo Laboratory was tasked with two major projects, both of which involved

scanning *Godzilla* films in 4K with the ARRISCAN. The first was a full digital restoration of the 1954 *Godzilla* commissioned by Toho, the company that had originally produced and distributed the film. The second was a television documentary produced by Nihon Eiga Satellite Broadcasting, which runs the Japanese Movie Channel on DBS, looking back at all 28 of the official Toho *Godzilla* films. While both projects were scanned in

4K, the former did so to maximize image quality in movie theaters, and the latter did so as part of a 4K television broadcasting test.

Godzilla was originally conceived as a metaphor for nuclear weapons, though the monster might also be seen to symbolize the threat of natural disaster, or even the vengeful rage of nature, retaliating against mankind's destructive ways. In any case the allegory was sufficiently universal for the

“The ARRISCAN achieves a level of sharpness that perfectly suits the emerging media of 4K broadcasting.”

Godzilla franchise to win fans all over the world. It was therefore vital to ensure that the restoration of images from these internationally admired films was carried out using the best available tools and expertise.

“Tokyo Laboratory was in a unique position to handle this restoration work, and not just because we’re a subsidiary of Toho,”

says Satoshi Kawamata, Deputy General Manager of the Image Media Department. “The *Godzilla* films have already been remastered and repurposed many times over the years, and staff members here have been involved in the processing and finishing of them all. They are familiar enough with the original images of the *Godzilla* series to instinctively determine the optimum quality for reproduction on a cinema screen or any kind of monitor.”

Unfortunately the original camera negative of the 1954 film has been lost, a fate sadly shared by many other historic Japanese films. All that remained for the restoration team to work with were two duplicate negatives and a master positive print. On the plus side, they had been preserved in good condition, as had film materials from the myriad sequels. In fact,

the materials displayed only relatively minor deterioration and it was possible for them to be scanned quite stably using pin-registration and the Soft Archive Mode on the ARRISCAN.

“The challenge that received our most careful attention was to prepare the first *Godzilla* for digital theater screenings in a way that reproduced the ‘film-like’ image experienced by audiences in 1954,” explains Yoshinori Kato, Chief Engineer of the digital restoration process. “This is different to the approach we might take with a restoration for a traditional DVD package, which requires object profiles to be sharp and noise to be discreet, optimizing the image definition for home-use displays.”

Kato continues, “We really appreciate the excellent image quality of the ARRISCAN and the way it accurately captures grain structure, which is an important characteristic



BEFORE



and regarded as part of the artistic expression in a film image. This is especially true of black-and-white films such as the original *Godzilla*, so we give real care and attention to the restoration of monochromatic film grains. ARRI has successfully ensured that the ARRISCAN does not express grain

as unpleasant granular noise, which can often happen with other equipment.”

Even though the final DCP of *Godzilla* was screened in 2K, since most of the digital theaters in Japan only have 2K projectors, it was so film-like that many audiences believed they were watching a celluloid print, which Tokyo Laboratory took as indicative of the restoration’s success. As well as the newly restored version, the ungraded 4K scan data has been kept for long-term preservation on LTO, for possible reuse in the future.

The other project taken on by Tokyo Laboratory, a 30-minute television program covering all 28 *Godzilla* films, required a different approach. The goal here was to optimize the scanned images for large consumer 4K displays, which necessitated some testing. Once all the films had been previewed, an offline EDL specifying what footage to use was created and then converted into a cut list.

Ryosuke Miki, Chief Engineer of film scanning and recording, notes, “This series of films has been continuously produced through 60 years of evolving film technology. It was unusual for us to be scanning such a wide range of different film formats on one project, from Academy, to anamorphic, to spherical widescreen and back to anamorphic. Fortunately the ARRISCAN could easily handle the multiple variations of format and aspect ratio, as well as the many optical composite shots in these films. We discovered that by using the ARRISCAN, even decades-old films can achieve a level of sharpness that perfectly suits the emerging media of 4K broadcasting.”

With the test broadcast of this 30-minute *Godzilla* retrospective proving a workflow for 4K transmission of restored historic films, and the fully restored 1954 *Godzilla* screening at 60 theaters across Japan, the two projects have proved a resounding success. This is especially relevant because they are the first restorations in the country to have been



Invasion of Astro-Monster TM&© 1954 TOHO CO., LTD

carried out without any funding or input from the National Film Center.

“I think these two projects could become precursors for film archiving and restoration on a commercial basis in Japan,” says Akio Watanabe, Director of the Visual Image Department at Tokyo Laboratory. “The only bottleneck in our restoration workflow was dust-busting, which was occasionally very time-consuming, but to address this we’re looking at expanding the archive functions of our ARRISCAN with other accessories offered by ARRI, such as Built-In Stabilization, Wet Gates and the Sprocketless Transport. Tokyo Laboratory is in a position to build the first independent film restoration business in Japan, and the ARRISCAN will play an important role.”



Godzilla TM&© 1954 TOHO CO., LTD



IN GHANA WITH AMIRA

DP Johann Perry captures with AMIRA on a documentary produced for the Vodafone Firsts campaign

Cinematographer and AMIRA owner Johann Perry recently filmed a short documentary about a Ghanaian youth soccer team that gets the opportunity to play in an English tournament. The 12-minute film, titled *My First International*, was commissioned by the agency AKQA and produced by Firecracker Films in London. It forms part of the Vodafone Firsts campaign, a series of branded documentary shorts, and was completed in just four shooting days.

“The AMIRA adapts quickly to any situation.”

What drew you to AMIRA?

As soon as I saw that ARRI was releasing a camera with well thought-out ergonomics and the beautiful ALEXA image, I ordered one. It was like having an ARRIFLEX 16SR 3 back on my shoulder again. That's how we used to work in documentaries, with a lovely little camera tucked in to our shoulder and feeling like we could capture anything because we weren't fighting our tools. After 15 years or so, it's exciting to get back to that.

So you were able to be responsive in your camerawork?

Being responsive is the most important thing on every shoot I do. In documentaries you have to be ready to go, because anything

can happen; I want to get the camera on a tripod or on my shoulder as quickly as humanly possible. I probably work about 150 days a year on totally different kinds of projects. You don't want to be spending a lot of time re-jigging your system for tomorrow's shoot; you want to be able to use the same camera day in, day out. With other cameras you can end up needing multiple bodies in different configurations, but the AMIRA adapts quickly to any situation.

Were you operating the camera on your own?

I've been doing my own focus for 15 years and I prefer to work that way. The peaking function in the AMIRA viewfinder is

really accurate, so even handheld at T1.3 I was perfectly happy pulling focus myself. With a 50 mm at T1.3 your subject's eyeball will be in focus but their ear and the front of their nose will be soft; the peaking means you can see exactly what you've got. I found the whole viewfinder setup, with its focus and exposure tools, to be fantastically fluid and effortless.

What kinds of different lighting conditions did you encounter?

We had pretty much every lighting situation you could imagine. There was bright midday sun, dark subjects against hot windows, night-time interiors and exteriors, and mixed lighting with fluorescents and tungsten. I was amazed how well the AMIRA handled all of that. The internal ND filters

were very useful and we used them all the time. If I wanted to keep shooting at T1.3 but things suddenly got brighter, I could make a quick adjustment to the internal filter and keep my stop.

How did the director and producer respond to your images?

They were just delighted and couldn't praise the images highly enough. All the recent feature films we love were shot with the ALEXA, from *Dallas Buyers Club* to *Gravity*, so for a director or producer to have images of that quality on a documentary is something they get incredibly excited about. Especially shooting in Log C and then using a good color tool to show them the pictures; it just puts a big, beaming smile on their faces.

Did the CFast 2.0 workflow allow you to turn footage around as quickly as you needed?

It was remarkable that we were able to film a football match in England, edit it on-site on laptops, upload that to YouTube and broadcast it to a village in Ghana within a three-hour window. There was a lot of pressure to make it work, with 200 people sitting in the village hall, waiting to see their boys who had just played a match over 3,000 miles away. No other camera system could have delivered such great images so quickly.





PRORES UHD WITH AMIRA

A new software upgrade will allow AMIRA to record ProRes UHD files, answering the 4K requirements of some productions

DELIVER ANY FORMAT

While widespread adoption of 4K or UHD for broadcast is still a long way off, an increasing number of content owners are becoming concerned that they ought to safeguard the longevity of their programs by ensuring that they will be suitable for UHD transmission, should that become a standard in the future.

For those productions that do need to generate UHD deliverables, AMIRA will now

offer the ability to record all ProRes codecs in Ultra High Definition 3840 x 2160 resolution directly onto the in-camera CFast 2.0 cards, at up to 60 fps. This feature, which will be available for purchase at the online ARRI License Shop through an affordable software upgrade (and a sensor calibration for existing AMIRAs) by the end of 2014, comes in response to feedback from AMIRA customers, some of whom have been quizzed about 4K deliverables by clients. It is made possible by the camera's

exceptional image quality, its processing power, and its reprogrammable system architecture.

Whether a production is pursuing a UHD workflow all the way through to distribution, or simply wishes to archive in UHD in order to future-proof itself against industry developments, AMIRA will now offer an easy solution that requires no additional processes in postproduction.

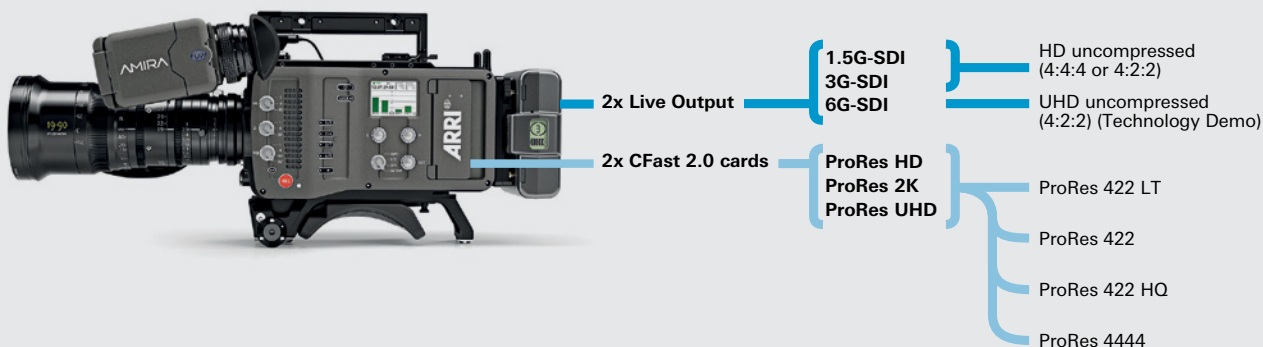

IN-CAMERA PROCESSING

The ALEXA/AMIRA sensor has repeatedly proved its ability to deliver outstanding image quality for the 4K or even IMAX theatrical releases of high-end feature films such as *Gravity*, *Maleficent* and *Iron Man 3*. This proves that the ALEXA and AMIRA camera systems are already future-proof and more than suitable for the next generation of distribution formats.

For major feature films, an up-sample to 4K can be carried out after visual effects and other postproduction tasks have been completed at 2K resolution. For certain fast-paced AMIRA productions, however, there may not be the time or resources for

such processes in post, which is why a 4K or UHD output direct from the camera has been requested.

AMIRA's UHD output utilizes the same efficient 1.2x up-sample filter that allows

ALEXA's Open Gate mode to optimize the camera's image performance for 4K distribution, as well as the same best-in-class sensor pixels. The up-sample to UHD happens in camera, and in real time.

AMIRA Image Path

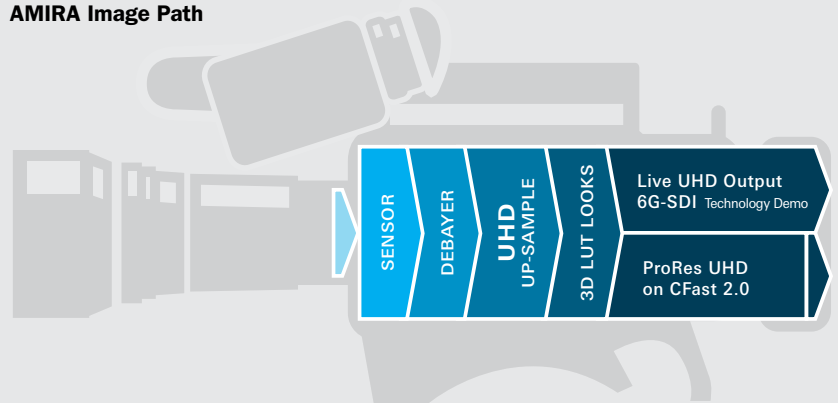

AMIRA Sensor



3200 x 1800 photosites used for 1.2x up-sample to **ProRes UHD**

3424 x 1926 photosites total sensor area including viewfinder surround view

SAME GREAT IMAGE QUALITY

Outputting UHD broadens the distribution options for the superior image quality that has helped make AMIRA, and ALEXA, such a success. The wide, 14+-stop dynamic range remains unaltered, as does the accurate colorimetry, natural skin tones, and organic look and feel. By making that high-quality image data coming out of the sensor compatible with higher spatial resolution formats, the UHD upgrade answers the

concerns of certain regions and productions about a 4K future, allowing AMIRA to be used on any project, no matter what deliverables are required.

Wildlife cinematographer Rolf Steinmann, who was nominated for an Emmy® Award this year in recognition of his work with ALEXA on the BBC's *Wild Arabia* series, is currently using his AMIRA on a movie for Disney Nature. He comments, "For cameramen like

me who own their gear, the UHD upgrade is a great way to stay future-proof. From now on when there's pressure from the production side to deliver UHD, I can continue to work with AMIRA and won't have to compromise on image quality or on the camera's robustness and reliability."



“When there's pressure from the production side to deliver UHD, I can continue to work with AMIRA and won't have to compromise on image quality.”

Rolf Steinmann, Emmy®-nominated wildlife filmmaker and AMIRA owner

SUP 1.1

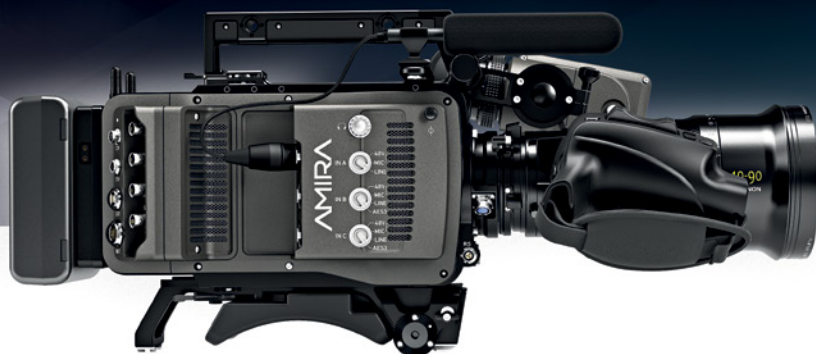

AMIRA EVOLVES

The first major software update for AMIRA, SUP 1.1, brings promised features and responds to user feedback

Already at work on a huge variety of productions worldwide, the AMIRA camera is a flexible tool that will evolve and adapt to customers' needs, maximizing the return on their investment. Following the same model that has allowed ALEXA to maintain dominance for more than four years, software updates will deliver new features in response to market changes and the requests of real-world users. For AMIRA shooters, that journey is only just beginning, with SUP 1.1 due for release in October 2014.

PROMISES FULFILLED

Temporary licenses

As of SUP 1.1, AMIRA Advanced and Premium temporary licenses will be available at the online ARRI License Shop. Activated on a weekly basis, they provide a uniquely adaptable solution for the variable needs of owner-operators.

EF and B4 lens support

With the forthcoming EF mount, AMIRA users can use EF mount stills lenses, controlling the iris in these lenses through the camera's user interface. B4-type lenses with an integrated servo module gain support for the auto iris function, while one other servo button can also be used as an assignable user button.

Bluetooth audio monitoring

This new feature allows the camera operator, or anyone else, to monitor audio through wireless Bluetooth headphones. By using a microphone-equipped Bluetooth headset, spoken comments can be recorded during filming to provide guidance for editing and postproduction tasks. These comments are recorded to a fifth audio track, aligned with the four main audio tracks, but kept separate from them.

Dynamic auto tracking white balance

For situations that involve a change of color temperature during a shot, the new dynamic tracking option makes an automatic white balance adjustment. Utilizing a sophisticated algorithm developed by ARRI, this adjustment is seamless, even for the most extreme color temperature transitions.



WiFi remote

SUP 1.1 will allow AMIRA's LCD panel to be displayed live on consumer wireless devices, permitting remote camera control without any need to hire additional tools. The HTML-based signal can be displayed on Android devices as well as iPhones or iPads. Alternatively, if wireless control is not required, a LAN-capable device (such as a laptop) can be connected to the camera via an Ethernet cable. The user interface replicates the camera's home screen menu, much like the AMIRA Simulator web tool.

Pre-record function

An internal buffer in the camera is used to record a perpetual loop, the length of which depends on selected options. When the REC button is hit, the clip recorded to the CFast 2.0 card will include the specified pre-record period at its start.

Pre-Record: Maximum Recording Times

	25 fps	30 fps	50 fps	60 fps	100 fps
ProRes 422 LT (HD/2K)	20 sec	16 sec	10 sec	8.3 sec	4.9 sec
ProRes 422 (HD/2K)					
ProRes 422 HQ (HD)	18 sec	15 sec	8.3 sec	7.4 sec	4.3 sec
ProRes 422 HQ (2K)	13 sec	11 sec	6.7 sec	5.5 sec	3.2 sec
ProRes 4444 (HD)	12 sec	9.9 sec	5.9 sec	4.8 sec	2.8 sec
ProRes 4444 (2K)					

USER REQUESTS

Faster boot-up time

AMIRA already boots up faster than ALEXA, but AMIRA users asked if it could be sped up even more. These requests were made a priority for SUP 1.1, resulting in a more than 25% reduction in the camera's boot-up time.

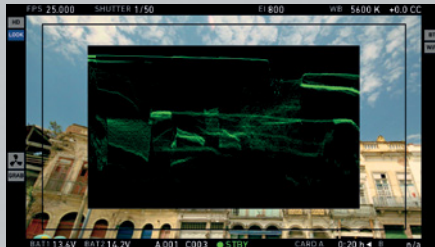

Waveform display

Some AMIRA users with an ENG background requested a waveform display on the camera's viewfinder image and LCD panel. This has duly been implemented, with the option to have the waveform full screen, or covering just a portion of the image, providing a further tool for judging exposure levels.

Color bar

From SUP 1.1, AMIRA will be able to generate a color bar that is viewable in the viewfinder, on the camera's LCD panel and on any connected monitors, allowing those monitors to be calibrated to match the viewfinder.

TECHNICAL REFINEMENTS

Enhanced HD-SDI outputs

AMIRA's HD-SDI output has been refined to allow the overlay of information about timecode and other parameters that is seen in the viewfinder, to also be seen on monitors.



Additionally, it will now be possible to use an HD-SDI signal input as a further 'genlock-like' sync option.

Improved debayer

An improved debayer algorithm for AMIRA will now result in an even greater reduction of aliasing and noise, for smoother images.

LDS functionality

When using a Lens Data System® (LDS) lens on AMIRA's PL-LDS mount, data about iris, focus and zoom positions will now be visible in the viewfinder and all lens data will be embedded in the recorded QuickTime files.

MASTER ANAMORPHICS IN WINTER

Cinematographer Bradford Young braves the cold while shooting A Most Violent Year with ALEXA and ARRI/ZEISS Master Anamorphic lenses

DP Bradford Young on set
Photos: Atsushi Nishijima



A thriller set in New York in the winter of 1981, when crime in the city was rife, *A Most Violent Year* was directed by J.C. Chandor and shot by three-time Sundance Award-winning cinematographer Bradford Young. ARRI CSC supplied ALEXA XT Studio, XT Plus and XT M cameras, as well as Master Anamorphic lenses, although only three focal lengths were available at the time of filming – the 35 mm, 50 mm and 75 mm.

What led you to anamorphic capture?

When I read the script I definitely felt it should be shot in 2.35:1. I did consider 2-perf 35 mm with older spherical glass, but when we went with ALEXA I knew I wanted to combine it with anamorphic

lenses. I felt it was important to be true to the scope format, so I didn't want to shoot 1.78:1 and crop to 2.35:1; I thought that would create an artificial tension to the framing and I preferred the idea of being locked into our compositions without a lot of room to adjust.

So the fact that ALEXA's 4:3 sensor was almost completely utilized by the anamorphic lenses felt like a 'truer' use of the format?

That's it, exactly. I felt that the tension of not being able to make a mistake and fix it in post would force us to construct really precise frames. Sometimes that meticulousness can get lost when you're cropping from a 16:9 frame, and a sense of precision was exactly what we were trying to achieve for the story.

Was that sense of precision aided by the optical performance of the Master Anamorphics?

Yes, absolutely; the 35 mm Master Anamorphic was incredible in the way it held detail right into the corners. There wasn't any sort of barreling or wrap-around, and there wasn't a sweet spot like you get with other anamorphic lenses. So many of our compositions were about lines, and I wanted those lines to stay straight wherever they were in the frame. The precision of the Master Anamorphics helped me stay anchored to the aesthetic we had chosen for the film.

“The 35 mm Master Anamorphic was incredible in the way it held detail right into the corners.”

The fact that the Master Anamorphics are so fast at T1.9 was also significant. I like to shoot wide open and to use very little light, so for all of our day interiors, night interiors and night exteriors we were shooting at T1.9. In the past the limitations of anamorphic lenses have to some degree dictated the

aesthetics of anamorphic films, but that isn't the case anymore. The Master Anamorphics are liberating because they allow you to shoot and light a scene in whatever way you like, without restriction.

At the time only three focal lengths were available; was that restricting?

I was trained in an environment where we didn't have a lot of resources, and I've shot films before where we only had one or two pieces of glass, so I wasn't really worried about being restricted with focal lengths. I was more concerned about having enough glass for situations where we needed to shoot with two or three cameras. It would have been nice to have had the 100 mm or 135 mm, which weren't ready at that time, but again it added to a framing tension that ultimately helped the visual language of the film.

You shot through a fairly brutal winter, didn't you?

It was the coldest, snowiest winter in decades, and we shot right smack in the middle of it. Mother Nature put the Master Anamorphics under extreme test conditions, but not one lens barrel got sticky, and the ALEXAs never gave up on us. In fact the cameras and lenses did better than the crew; people were bailing out just because it was so cold!





THE BENEFITS OF LENS DATA

ARRI's Electronic Control System delivers lens data that improves workflows in post and on set, with any camera and any lens

WHAT IS LENS DATA AND WHAT IS IT GOOD FOR?

Lens data is a continuous stream of information about the focus, iris and zoom settings of a lens, as well as the depth-of-field range. It can be displayed on the Wireless Compact Unit WCU-4, giving full remote control to the focus puller even if the camera is out of sight. With ALEXA Plus and Studio cameras, lens data is also viewable on the monitor outputs, viewfinder and side panel display, so the DP can see what the lens is doing from anywhere on set. Additionally, lens data is an important prerequisite for lens mapping and focus tracking.

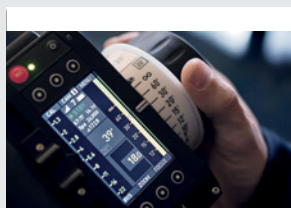

Lens mapping is the mapping of a lens focus scale to a predefined, pre-marked focus ring. This saves time in prep, as the camera assistant does not have to mark up an individual ring for each lens. It also simplifies

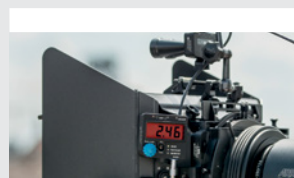

work on set, as the five pre-marked rings will cover multiple different lenses. With fewer rings, the focus puller will get familiar with them faster, allowing more intuitive focus pulling.

Focus tracking is a continuous, automatic focus adjustment based on the distance measured by an ultrasonic measuring device such as the UDM-1.



As well as offering on-set benefits, ARRI lens data reduces the time and effort required to achieve complex visual effects by helping to match a virtual lens to the recorded image in postproduction, or even driving the virtual lens optics in a real-time VFX system on set. Frame-accurate lens data is recorded in-camera by any ARRI digital camera equipped with a PL-LDS mount, or recorded by the Universal Motor Controller UMC-4 with any other camera, from any manufacturer.

HOW IS LENS DATA GENERATED?

Lens data generation has two basic requirements: first, the system needs to know where the lens ring is. This information comes from encoders, which are either built into the lens (LDS lenses), located inside lens motors or housed in a separate unit, like the Lens

Data Encoder LDE-1. Second, the system needs to have a lens table that converts the raw encoder values into something a human can use, like T-stops and focus ring values. ARRI offers two basic configurations:

Option 1: LDS lens and LDS camera

Each LDS lens can detect the position of its lens rings and store its own lens table. When mounted to a PL-LDS mount camera, the data is transmitted directly to the camera, which calculates precise lens values, accurate to the frame.

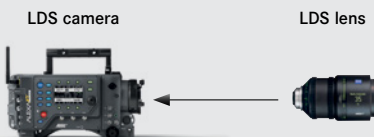

Option 2: External lens encoders and the Lens Data Archive

ARRI's controlled lens motors and the Lens Data Encoder LDE-1 deliver raw data about the position of the lens rings to either a UMC-4 or an ALEXA Plus module. These devices incorporate the LDS Lens Data Archive, which provides the relevant lens table used to calculate the lens value.

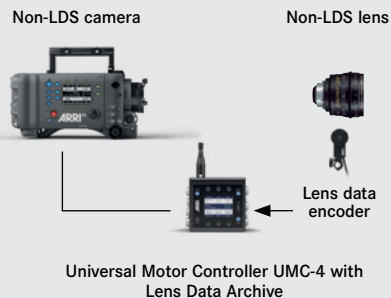

WCU-4 SOFTWARE UPDATE 2.0 ALLOWS EASIER LENS PROGRAMMING

Through lens programming, lens tables can be generated for any lens, from vintage anamorphics to modern PL mount zooms, allowing them to be controlled – and lens data to be collected from them – via the Electronic Control System.

Software Update Packet (SUP) 2.0 for the WCU-4 makes lens programming easier than ever before. The hand unit now offers an interface for lens programming on its large LCD screen, so a lens scale can be programmed wirelessly in less than a minute, with no additional equipment besides the WCU-4, UMC-4 (or an ALEXA Plus or Studio camera) and lens motors. The resulting lens file is stored on an SD card, which can be taken out and reused elsewhere.

Additional features of WCU-4 SUP 2.0 include minor bug fixes and improvements made in direct response to customer feedback. Software updates such as this one permit the Electronic Control System to evolve and adapt, making it future-proof and a sound long-term investment.



LENS DATA ENCODER LDE-1



The new Lens Data Encoder LDE-1 extends the functionality of the Electronic Control System. Incorporating an encoder that delivers data indicating the position of the lens ring to which it is attached, the LDE-1 can be used in parallel with a manual follow focus unit or a third-party wireless lens control system. It allows lens data to be generated in

situations when an ALEXA Plus or Studio (or a UMC-4) is being used without an ARRI lens motor or an LDS lens.



Download the system brochure here:
www.ari.com/goto/0914/ecs



L-SERIES MAKES THE NEWS

German TV news provider Tagesschau saves money and gains full color controllability by outfitting its new studio with ARRI L7-C LED Fresnels

Tagesschau is a German national and international television news service produced by Norddeutscher Rundfunk on behalf of the German public service television network ARD. The main edition of the program is aired daily at 8:00 pm on Das Erste, the principal public TV channel. It is also simulcast on several ARD-affiliated networks and broadcast 24 hours per day via the digital channel Tagesschau24.

Having outgrown the studio it had occupied for the last 10 years, Tagesschau completed construction in 2014 of a new 320 m² studio, at a cost of €23.8m. This state-of-the-art facility is now home to the 20 programs broadcast by Tagesschau every day, among them the television magazine *Tagesthemen*, the night show *Nachtmagazin* and the weekly review *Wochenspiegel*.

Forming the backdrop of the new studio is a large, curved media wall, capable of adapting to the graphics needs of the various different shows. The optimal brightness of the media wall projector is 20,000 ANSI lumens, but during testing it transpired that



this level could only be achieved by setting the color temperature to 6,000 K. When this was reduced to 3,200 K (the same color temperature as all the other lights in the studio), the projector's luminous intensity fell significantly. At the average camera aperture of T5, this resulted in the media wall appearing much darker than the news presenters standing in front of it.

Clearly, the ideal solution was to find a way of setting the Fresnel lights illuminating the news presenters in the main body of the studio to 6,000 K, as this would match the media wall when set to its optimal luminosity. Unfortunately, conventional tungsten Fresnels would not be able to do this, so ARRI provided some demo L-Series fixtures to the studio via its system partner, Medientechnik Duwe.



Following a successful demonstration, 99 ARRI L7-C lights were ordered for the new studio, with the installation planned and supervised by Medientechnik Duwe. L-Series lampheads were chosen because they offer the familiar feel of a traditional Fresnel, but with the versatility and power savings of a fully tuneable LED fixture. There is no change in color temperature when the

L7s are dimmed, and their true Fresnel characteristics allow the news presenters to be lit flatteringly and precisely, without any spill light falling on the media wall. Tagesschau's desired color temperature of 6,000 K falls easily within the 2,800 K to 10,000 K range of the L7-C.

Compared to the old studio with its tungsten lighting, the new ARRI L-Series units

facilitate a power saving of approximately 60%. In addition, maintenance costs are reduced by the fact that the estimated lifetime of the LED light engine is 50,000 hours, and unlike conventional lights, there is no need to change bulbs or color filters.



L5 AVAILABLE WORLDWIDE

*The new L5 LED Fresnel expands
ARRI's L-Series, offering the
same outstanding features as the
L7, but in a smaller package*



Orders are already being fulfilled worldwide for the recent addition to ARRI's L-Series, the compact and lightweight L5. The L-Series started with the L7, an LED Fresnel that provides the same light qualities as a traditional tungsten Fresnel, but with the added features of full CCT tuneability and color selection. The L5 now extends this successful line of products in a smaller, more portable form.

Like the L7, the L5 Fresnel comes in three versions: the L5-C (Color), L5-TT (Tungsten Tuneable) and L5-DT (Daylight Tuneable). While the L5-C is the most



L5-C

2,800 - 10,000 K



L5-T
TUNEABLE

2,600 - 3,600 K



L5-D
TUNEABLE

5,000 - 6,500 K



L5 MAIN FEATURES

- Half the size and weight of the L7
- Full tuneability from 2,800 K – 10,000 K
- Green/magenta correction and vivid color selection
- 45% brighter than a 300 W tungsten Fresnel
- Portable, with on-board battery input
- Robust build quality and familiar form factor

versatile with regard to color tuneability, the L5-TT and L5-DT are 25% brighter than the L5-C and still offer a select CCT tuning range.

Despite drawing only 115 watts, the L5 is approximately 45% brighter than a 300-watt tungsten Fresnel, with a light output equivalent to a 450-watt tungsten fixture. When compared to the L7, the L5 is half the weight and size. In addition, the L5 maintains all the popular features of its larger sibling, including tuneability from 2,800 K to 10,000 K; green/magenta correction; hue selection; saturation control;

and on-board DMX for communication with third-party control products.

New features of the L5 include a PowerCON power connector and an on-board battery input that allows industry-standard batteries to power the lamphead without any sacrifice in functionality or light output. The resulting increase in portability opens up whole new application areas, giving productions with the L5 tremendous freedom to move fast and work in locations without AC power.

The L5 perfectly complements the L7, facilitating more mobile lighting and a wider

range of power classes for television studios. Its compact size and low weight permit the L5 to be rigged in tight places and hung from low ceilings. The L5 is also ideal for cramped location shoots and interview setups, with the low heat output creating safer and more comfortable shooting conditions. This versatility, combined with the superb light quality, makes the L5 a welcome addition to the award-winning L-Series family.



ELEMENTARY

Photo: Mark Schafer
All photos ©2013 CBS Broadcasting, Inc.



DP Ron Fortunato, ASC

Recently renewed for a third season, *Elementary* is a U.S. crime drama series that puts a contemporary spin on Sir Arthur Conan Doyle's Sherlock Holmes characters, with Lucy Liu playing a female Dr Watson to Jonny Lee Miller's New York-based Holmes. Cinematographer Ron Fortunato, ASC, has shot the majority of episodes through the first two seasons, utilizing an ALEXA camera package supplied by ARRI CSC and recording ProRes 4444 Log C.

What do you enjoy about working in television?

It's a bit of a cliché but people are saying that we're in the second golden age of television. It used to be seen as less challenging than feature films, but the writing and the character of the shows has changed, and today's big-screen TVs are another factor. You have more cinematic possibilities now and you don't have to shoot everything in close-ups; it's attracting not only crew people that wouldn't have done television years ago, but actors as well. Personally I love storytelling and the human aspect of filmmaking, and these days there's more of that in television than in movies.

Nelson Cragg shot the pilot on ALEXA; was there any discussion of switching to a different camera?

No, I was very happy to have the ALEXA; I first used it on *Pan Am* and fell in love with it. It's not very often that a piece of equipment



“With ALEXA the exposure in the high end is a big improvement.”



comes along that really is a game-changer, but ALEXA certainly was – just the quality of it, and the speed; I can shoot by candlelight now. It's a whole different story to when I first shot with digital at the request of Sidney Lumet, for a film I did with him 14 years ago. I idolized Sidney and would have shot with anything he wanted, but when you compare what was possible then with the ALEXA, it's like night and day.



Ron Fortunato, ASC, discusses working with ALEXA on the CBS Sherlock Holmes series

*Lucy Liu directing the episode Paint it Black
Photo: Jeff Neumann*



Photo: Jeffrey Neira

How do you use the Zeiss Standard Speeds and Angenieux zooms you have on the show?

You need zooms on TV, so we're on those most of the time, although I use the Zeiss primes a lot for flashbacks. I would like to use the primes more because I love the quality they have on HD and there is a trend right now to use older glass. Everything has gotten so sharp, but sometimes a little softness and a little imperfection can be great.

Have you encountered any pressure to shoot 4K?

Not yet. It's probably coming and I don't think it's necessarily a good idea. Of course we'll have to embrace it, but I think it's going to be used for the wrong reasons. I'm concerned that the resolution could be used in postproduction to recompose shots. But I've learned since this digital revolution started to make the best of things as they come along; you've just got to use them to your advantage.

Is it a challenging show to light?

I'm definitely working at a substantially lower light level than I have in the past. Previous digital cameras were about 320 ASA, but the ALEXA is 800 and when you push to 1,600 there is no discernable difference. It has much better latitude, so not only are you using less light – you're also a little bit less worried. One of my biggest complaints with

HD used to be that highlights disappeared, but with ALEXA the exposure in the high end is a big improvement.

We're allowed to light TV shows like movies now, in fact it's expected. They want a moody, cinematic look for almost every series, so as cinematographers we're in a very good place. The challenge comes when you have to do it in a third of the time, which can be difficult sometimes, but it's great. It makes you stronger as a DP.



SMB-1: THE *TILTING* MATTE BOX

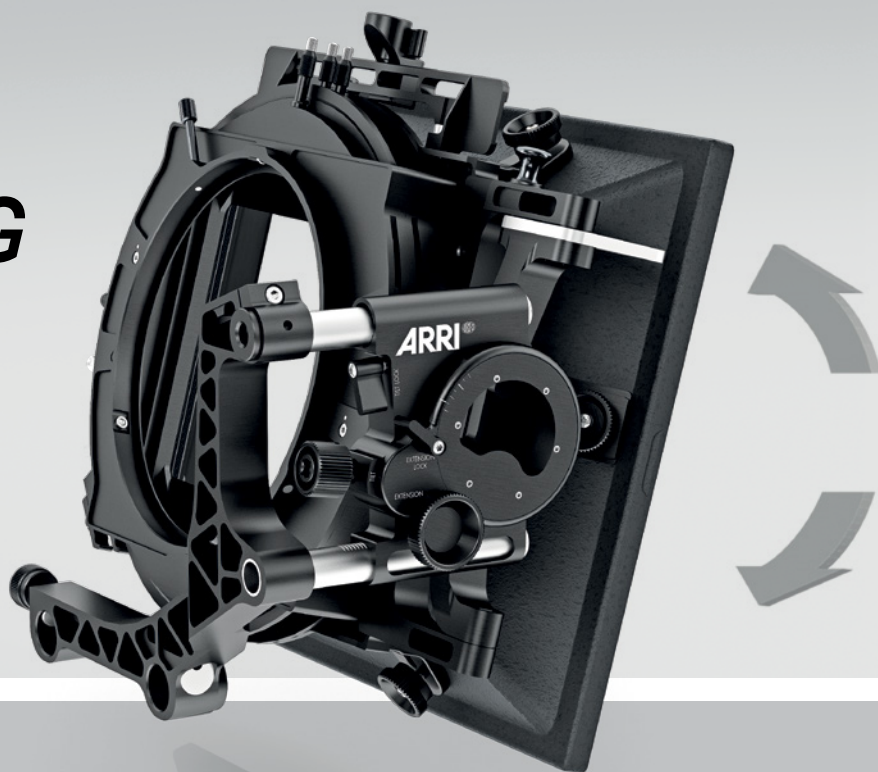

DP Bojan Bazelli, ASC, and 1st AC John Holmes test the new Studio Matte Box SMB-1 prior to taking it out on a feature film

Spectral, a sci-fi thriller about a special ops team fighting supernatural beings that have overrun New York City, is the feature debut of commercials director Nic Mathieu. While readying their camera equipment for the shoot in a test room at ARRI Rental Budapest, cinematographer Bojan Bazelli, ASC, and 1st AC John Holmes spoke to ARRI News about why they had requested the new ARRI Studio Matte Box SMB-1, with its integrated tilt module and anamorphic accessories.



DP Bojan Bazelli, ASC (right)
with 1st AC John Holmes

What cameras and lenses are you using on this production?

Bojan Bazelli: We're using three ALEXA Studio XTs and also the ALEXA M. It's an anamorphic project and our main lenses will be ARRI/ZEISS Master Anamorphics, because of their ability to shoot wide open without any compromise in quality. They also display no breathing at all when pulling focus, and no distortion.

Why did you decide to try the new SMB-1?

BB: To be honest I put the SMB-1 on my gear list for *Spectral* without studying all the features in depth. I'd heard that it had a tilting function and anamorphic accessories, but I wanted to try it mainly because it is something new from ARRI. I've always used ARRI cameras, starting with an ARRIFLEX 35 BL on my shoulder when I was 17, so I have a lot of trust in the products.

Having tested it, what do you think of the new stackable filter stage modules?

John Holmes: I like the new design. Not only does it reduce the amount of filter stages you have on the camera, but it also gives you flexibility in building five possible configurations.



SMB-1 MAIN FEATURES

- Integrated tilt module counteracts reflections
- Stackable filter stage modules
- Anamorphic sunshade, side flags and matte set
- Versatile accessory mounts
- Advanced adjusters for flags
- Takes filters up to 6.6" x 6.6"
- Ideal for zooms and wide-angle primes

What kinds of situations will the tilting function be useful for?

BB: Sometimes under special lighting conditions you can get reflections between filters or between a filter and the front of the lens. It is difficult to predict when this might happen, so having a module integrated into the matte box that allows you to quickly eliminate these reflections by tilting the whole filter assembly is a big improvement over the workarounds we had to use before.

How about the anamorphic accessories?

BB: Anamorphic is very popular at the moment, so it makes a lot of sense to have accessories specific to that format. When you

compare them, the difference between the opening of the 4:3 spherical sunshade and the 2:1 anamorphic one is huge. Using these accessories when shooting anamorphic with the SMB-1 is just an efficient way to work and helps keep everything as compact as possible.

Does the SMB-1 have the ergonomics and build quality to stand up to your shoot?

JH: In terms of ergonomics, new features like the single-knob locking mechanism on both rods, the sliding accessory mount for ultrasonic distance measurers, the friction-driven side flaps on the top flag, and the fast adjuster for the top and side flags, will all make life easier and faster on set. If I had to choose a single feature that I like the best, the new fast adjuster for the top flag is brilliant. These features – and the fact that you are visiting us while we're testing – show that ARRI quality is not just about product reliability, it's about listening to the real needs of crews.



See the SMB-1 tilting here:

www.arri.com/goto/0914/smb-1



THAT MOVIE LOOK

ARRI/ZEISS Master Anamorphic lenses help lend a cinematic feel to a series of Ford TV spots



For a new Ford campaign, director Kurt Mattila and producer Alexander Dervin developed the idea of a series of commercials that feel like clips from the same movie. Each individual spot focuses on a specific Ford vehicle, while also being part of a bigger super-hero thriller.

“Kurt and I knew a widescreen frame would accommodate the five cars and seven actors,” says cinematographer Keith Dunkerley. “We really wanted to shoot with anamorphic lenses because you get a more cinematic look.”

Having chosen the ALEXA XT as his camera for the shoot, Dunkerley asked Kavon Elhami of Burbank-based camera rental house CamTec Motion Picture Cameras to show him anamorphic lenses. “Kavon was so helpful with this process,” says the cinematographer. “He had a wide variety of anamorphic lenses and brought out every single one, showing me different looks and the quality of the glass.”

Dunkerley immediately gravitated toward ARRI/ZEISS Master Anamorphics. “The lenses were amazing; they were clearly the right glass for the project,” he says. “Kurt was really excited and backed me up. Being able to combine the Master Anamorphics with the ALEXA’s 4:3 sensor was just what we wanted.”

The creatives at ad agency Team Detroit wondered if there might be edge artifacts, a common issue with older anamorphic lenses, but Dunkerley showed them how the Master Anamorphic image was completely undistorted, from edge to edge. “The focus looked fantastic and the background dropped off in that classic anamorphic way,” he says. “These lenses also didn’t flare easily, and they captured incredible detail. I assured Team Detroit that there would be no distortion and that this was the look we should go for.”

With 14 spots to complete in just nine shooting days, the crew appreciated how the Master Anamorphics helped streamline a pressured schedule. 1st AC Shaun Mayor notes, “The lenses are matched pretty closely so it made calibration very fast.”

We had the 35 mm, 50 mm, 75 mm and 100 mm, and aside from the 100 mm being slightly heavier, they all weighed the same. This was great because we didn't have to rebalance the camera as we switched lenses. We could also use the same-sized matte box because the Master Anamorphics have the same front diameter. Our days were very ambitious, so speed was definitely a good thing."

The relatively light weight of the Master Anamorphics was another useful feature. "Some older anamorphic lenses are much bigger and heavier," says Dunkerley. "The Master Anamorphics are great for handheld work and our Steadicam operator Ari Robbins loved working with them."

"I couldn't believe how well the lenses held up and just how great the colors matched."

For night driving scenes, the crew often worked in low light conditions. "In some locations we used practicals supplemented by just a couple of small Kinos, with bigger units further away," says Dunkerley. "With

most anamorphic lenses you need to shoot about a T4 or T4.5 to get a crisp image, but with the Master Anamorphics I was able to shoot wide open and the image looked fantastic. I couldn't believe how well the lenses held up and just how great the colors matched."

Debra Kaufman



Photo: Chris Frawley

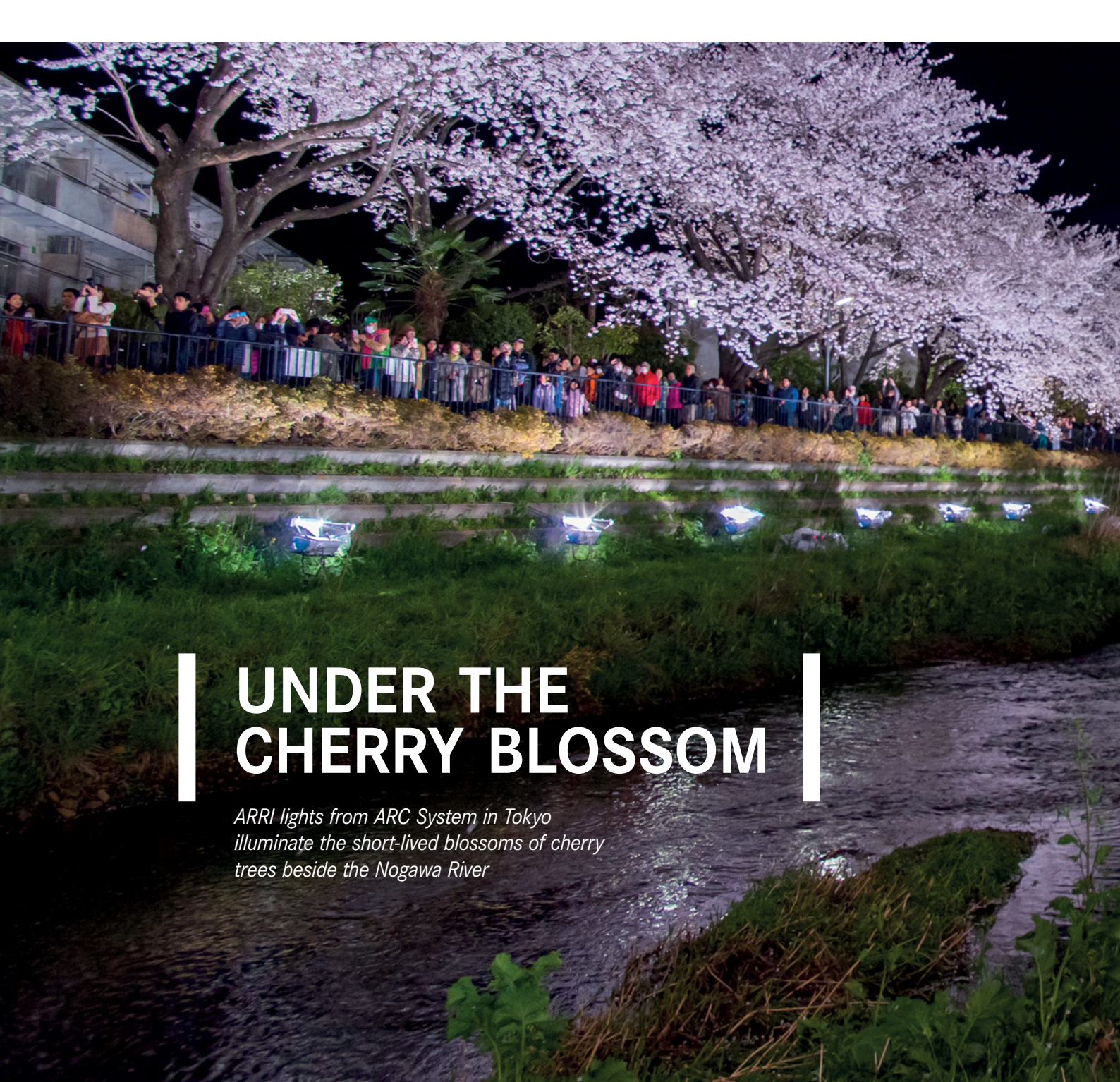

UNDER THE CHERRY BLOSSOM

ARRI lights from ARC System in Tokyo illuminate the short-lived blossoms of cherry trees beside the Nogawa River

In Japan, the fleeting beauty of the springtime cherry blossom is rich in cultural significance and highly anticipated every year. Detailed forecasts from the Japanese Meteorological Agency track the progress of the cherry blossom front, or *sakura zensen*, as it moves northward from late March through April, spreading a blanket of delicate pink flowers over the country.

Since the flowers only stay on the trees for a week, they are revered not only for their

beauty, but also for their poignant transiency – a reminder of the ephemeral nature of life. The centuries-old practice of picnicking under the bloom of the cherry blossom has evolved into today's Hanami festivals, which see the population gathering together at parks and public spaces to enjoy the spectacle.

ARC System, a prominent Japanese lighting equipment rental company, has an annual tradition of illuminating cherry trees along the Nogawa River in Chōfu, west Tokyo,

for just one night of the blossom. The tradition started when the company up-lit a single tree for the benefit of its employees, but has grown into a major seasonal event, attended by thousands of local residents and widely covered in the media.

For the 2014 event, 93 cherry trees along 650 meters of walkway beside the river were up-lit with 151 lampheads. ARRI daylight fixtures were selected for their powerful, high-quality light output, reliability



ARRI X 60



ARRI M18

and uniform color performance. They included X12, X40/25 and X60 units from the ARRI X range, which utilizes a unique reflector system to produce beautifully soft light with a wide 130° beam. An ARRISUN 40 was also used, as well as 1.2 kW, 2.5 kW and 4 kW ARRI Compact lampheads.

The stars of the show were M18 and M40 lights from ARRI's M-Series, a line of

state-of-the-art daylight lampheads featuring the patented MAX reflector. Combining the best elements of PAR and Fresnel fixtures, M-Series units incorporating MAX Technology® are open-face and thus very bright. They are focusable over a wide range of beam angles, producing a clear, crisp shadow.

Drawing 450 kW from five power supply vehicles, the 151 lights necessitated 250

cables, totaling five kilometers in length and weighing four tons. The exact arrival time of the cherry blossom varies each year according to climatic conditions, so the schedule for the one-night installation could only be fixed immediately before the event itself, giving ARC System employees just one day to set up all of the lampheads, stands and cables. Their hard work was worth it, though, because it gave the company a chance to connect with local society and to showcase the benefits of ARRI lights by accentuating the beauty of a Japanese tradition.

KEY CONTACTS

Europe, Middle East, Africa, India

Arnold & Richter Cine Technik
GmbH & Co. Betriebs KG
Headquarters
Munich, Germany
+49 89 3809 0

Arnold & Richter Cine Technik
GmbH & Co. Betriebs KG
Business Unit
Lighting & System Group
Berlin, Germany
+49 30 678 233 0

ARRI Italia S.r.l.
Milan, Italy
+39 02 2622 7175

ARRI CT Limited
London, Great Britain
+44 1895 457 000

www.arri.com
ARNOLD & RICHTER CINE TECHNIK
GmbH & Co. Betriebs KG
Türkenstr. 89 · 80799 Munich
Telefon +49 89 3809 0
Fax +49 89 3809 1244

Published by:

Arnold & Richter Cine Technik, Türkenstr. 89, 80799 Munich

Editor & Chief Copywriter:

Mark Hope-Jones

Additional contributors:

Markus Dürr, Syna Greiser, Debra Kaufman, Terry Leung, Sibylle Maier, Catia Marini, Susanne Mayer, Judith Petty, Stephan Schenk, Marc Shipman-Müller, An Tran, Stephan Ukas-Bradley, Philip Vischer, Hendrik Voss, Michael Wagner, Brigitte Wehner, Franz Wieser, Markus Zeiler

Main cover image: photo courtesy of Johann Perry, cinematographer on Firecracker Films' shoot for the Vodafone Firsts campaign. ARRI extends special thanks to the entire production crew and the Ghanaian families for their kindness and cooperation.

Editorial Design & Art Direction: polta.co

The opinions expressed by individuals quoted in articles in ARRI NEWS do not necessarily represent those of ARRI or the editors of ARRI NEWS. Because of our constant endeavour to improve quality and design, modifications may be made to products from time to time. Details of availability and specifications given in this publication are subject to change without notice.

Ident Nr.: 80.0003234

Americas

ARRI Inc. East Coast
New York, NY USA
+1 845 353 1400

ARRI Inc. West Coast
Burbank, CA USA
+1 818 841 7070

ARRI Inc. Central & Southern America
Fort Lauderdale, FL USA
+1 954 322 4545

ARRI Canada Limited
Toronto, Canada
+1 416 255 3335

Asia Pacific

ARRI Asia Limited
Hong Kong
+852 2571 6288

ARRI China Co. Limited
Beijing, China
+86 10 5900 9680

ARRI Australia Pty Limited
Sydney, Australia
+612 9855 4300



ARRIFLEX D-21



The German Film and Photo Technology Museum in Deidesheim houses one of Europe's most extensive collections of cameras and optical equipment, charting more than 100 years of technical development in the fields of stills photography, motion pictures, television and lenses.

Not only does the museum serve to educate visitors about the history of these disciplines, which have had such a profound impact on global society, it also facilitates the ongoing preservation of over 4,000 rare and delicate exhibits, representing our collective technical heritage.

Occupying a total area of some 300 m², the exhibits cover everything from Polaroid cameras to high-end electron microscopes. The evolution of motion picture technology can be traced from rudimentary magic lanterns to early wooden hand-crank cameras, and then on to sophisticated film cameras that were used on well-known blockbusters, as well as television studio cameras.

A number of vintage ARRI cameras are displayed in a special cabinet, including the ARRIFLEX 16ST and 16BL, which were ubiquitous 16 mm newsgathering cameras

TECHNICAL HERITAGE

ARRI continues its support for a German museum tracing the history of image-making technologies

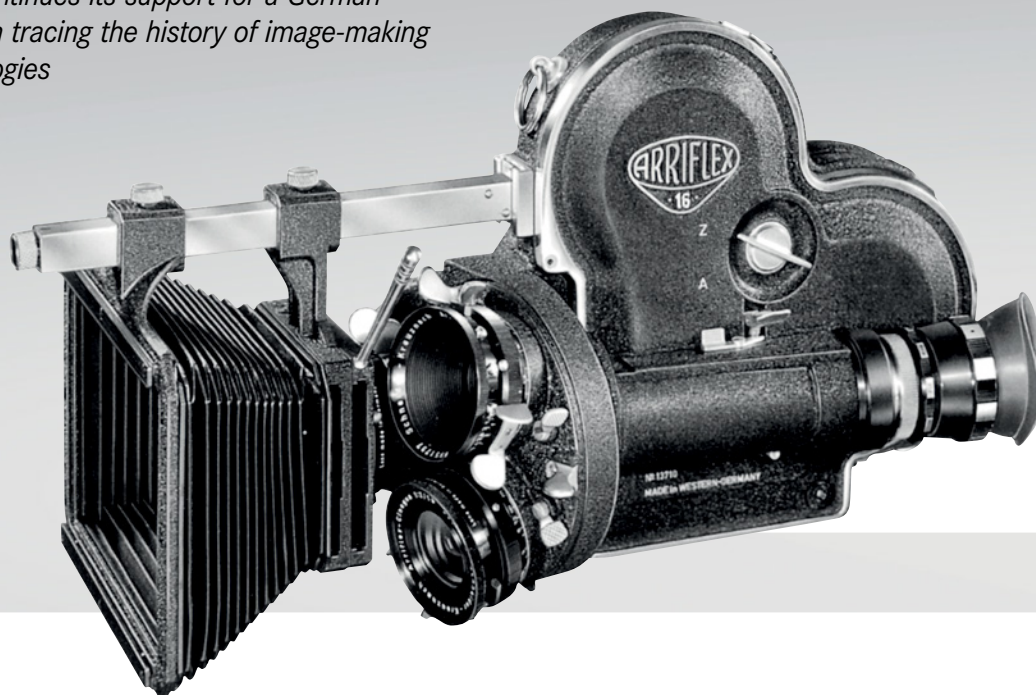

ARRIFLEX 16ST

during the mid-twentieth century, and variants of the famous ARRIFLEX 35, which in 1937 became the world's first movie camera to feature a rotating mirror shutter and reflex viewfinder. Alongside the cameras is a written history of the company and photographs of August Arnold and Robert Richter, who founded ARRI in 1917.

Museum Director Dr Wolfgang Immel, who put the collection together, has been in touch with ARRI since the 1970s, when his contact was Volkmar Öhme, Director of Public Relations and Advertising at that time. It was through this close relationship that ARRI cameras came to be so well represented in the collection.

When the museum was opened in 1990, a speech was given by Dr. Günther Schwab, formerly on the managerial staff at ARRI, entitled: "Film and video – will video technology make museum pieces of film cameras?" This subject has become ever more pressing and poignant in the years since, and the museum is now attempting to update its exhibits to convey today's



Dr Wolfgang Immel (center) receiving the German Federal Cross of Merit

transition from analog to digital image capture, as well as possible future developments. To this end, ARRI is donating further information and equipment, with Dr Martin Prillmann, Executive Board Member of ARRI AG, pledging to provide the museum with an ARRIFLEX D-21, one of the company's first digital cameras.

Recognizing his tireless work building the collection and maintaining it as a publically accessible educational resource, Dr Wolfgang Immel was awarded the German Federal Cross of Merit in July 2014. This prestigious accolade was ceremoniously presented by Culture Secretary Walter Schumacher, on behalf of the President of the Federal Republic of Germany, Dr Joachim Gauck. ARRI warmly congratulates Dr Immel on his award, and on the continuing success of his museum.

Cross of Merit in July 2014. This prestigious accolade was ceremoniously presented by Culture Secretary Walter Schumacher, on behalf of the President of the Federal Republic of Germany, Dr Joachim Gauck. ARRI warmly congratulates Dr Immel on his award, and on the continuing success of his museum.

DEUTSCHES FILM + FOTOTECHNIK MUSEUM
Weinstrasse 33
D 67146 Deidesheim



THE BIGGER PICTURE

FOR THE FIRST TIME, A SUPER-WIDE ZOOM WITH NO DISTORTION AND NO COMPROMISE



ARRI ULTRA WIDE ZOOM 9.5-18/T2.9. TRULY CINEMATIC.



www.arri.com/qr/an/uwz

ARRI 