

ARRI Impression V Filters

USER MANUAL

March 23th, 2023

Imprint

© 2023 Arnold & Richter Cine Technik GmbH & Co. Betriebs KG. All rights reserved.

The system contains proprietary information of Arnold & Richter Cine Technik GmbH & Co. Betriebs KG; it is provided under a license agreement containing restrictions on use and disclosure and protected by copyright law. Reverse engineering of the software is prohibited.

No part of this publication may be reproduced, stored in a retrieval system, or transmitted in any form or by any means, electronic, mechanical, photocopying, recording or otherwise without the prior written permission of Arnold & Richter Cine Technik GmbH & Co. Betriebs KG.

Due to continued product development the information in this document may change without notice. The information and intellectual property contained herein is confidential between ARRI and the client and remains the exclusive property of ARRI. If you find any problems in the documentation, please report them to us in writing. ARRI does not warrant that this document is flawless.

Original version.

For further Assistance

Arnold & Richter Cine Technik GmbH & Co. Betriebs KG
Herbert-Bayer-Straße 10
80807 Munich
Germany

E-mail: service@arri.com

Website: www.arri.com

Table of Content

1	About this Document.....	6
1.1	Intended Use.....	6
2	About this Product.....	7
2.1	Introduction.....	7
2.2	Content of ARRI Impression V Products.....	9
2.3	Identification of Impression V Products.....	11
2.4	Certifications and Safety Standards.....	12
3	Safety Instructions.....	13
3.1	Safety Conventions and Product Labels.....	13
3.2	General Safety Instructions.....	14
4	The Use of ARRI Impression V Filters with ARRI Cameras and Lenses.....	15
4.1	Magnetic Holding System.....	15
4.2	The Use of Impression V Filters with 1.7x Zoom Extender.....	16
4.3	Compatibility Information.....	17
5	Handling of In-camera Filter of LPL Mount for ALEXA.....	18
5.1	Removal of In-camera Filter.....	18
5.2	Insertion of In-camera Filter.....	19
6	Optical Properties.....	21
7	Required Shimming Depending on T-Stop.....	22
7.1	Shimming of LPL Mount.....	22
7.2	Lens Metadata and Shimming of LDS Contact Block.....	23
7.3	Shimming Tools.....	25
7.4	The Use of the Torque Screwdriver.....	26
7.5	Shimming Procedure.....	29
8	The Use of Velcro® Tabs.....	31
8.1	To Attach Velcro® Tabs.....	31
8.2	To Label and Clean Velcro® Tabs.....	32
8.3	To Remove a Velcro® Tab.....	32
9	Cleaning.....	33
9.1	Recommended Cleaning Agents.....	33
9.2	Cleaning Procedure.....	34
9.3	Cleaning Procedure for Aluminum Case.....	34
10	Transportation and Storage.....	35
10.1	Aluminum Case.....	36
10.2	Storage Boxes.....	37

11	ARRI Impression V Product Range.....	38
12	ARRI Service Contacts.....	42
13	Dimensional Drawings.....	44

Disclaimer

Before using the products, be sure to read and understand all respective instructions.

The products are available for commercial customers only.

For product specification changes since this manual was published, refer to the latest publications of ARRI data sheets or data books, etc., for the most up-to-date specifications. Not all products and / or types are available in every country. Please check with an ARRI sales representative for availability and additional information.

ARRI assumes no responsibility for any errors that may appear in this document. The information is subject to change without notice.

While ARRI endeavors to enhance the quality, reliability and safety of their products, customers agree and acknowledge that the possibility of defects thereof cannot be eliminated entirely. To minimize risk of damage to property or injury (including death) to persons arising from defects in the products, customers must incorporate sufficient safety measures in their work with the system and have to heed the stated canonic use.

ARRI or its subsidiaries expressly exclude any liability, warranty, demand or other obligation for any claim, representation, or cause, or action, or whatsoever, express or implied, whether in contract or tort, including negligence, or incorporated in terms and conditions, whether by statute, law or otherwise. In no event shall ARRI or its subsidiaries be liable for or have a remedy for recovery of any special, direct, indirect, incidental, or consequential damages, including, but not limited to lost profits, lost savings, lost revenues or economic loss of any kind or for any claim by third party, downtime, good will, damage to or replacement of equipment or property, any cost or recovering of any material or goods associated with the assembly or use of our products, or any other damages or injury of the persons and so on or under any other legal theory.

Neither ARRI nor its subsidiaries assume any liability for infringement of patents, copyrights or other intellectual property rights of third parties by or arising from the use of ARRI products or any other liability arising from the use of such products. No license, express, implied or otherwise, is granted under any patents, copyrights or other intellectual property right of ARRI or others.

ARRI or its subsidiaries do not assume any responsibility for incurred losses due to improper handling or configuration of the filter or other system components, due to contamination, defective signal connections or incompatibilities with third party equipment.

In the case one or all of the foregoing clauses are not allowed by applicable law, the fullest extent permissible clauses by applicable law are validated.

ARRI is a registered trademark of Arnold & Richter Cine Technik GmbH & Co Betriebs KG.

This product contains licensed technology from Linotype.

1 About this Document

This user manual is aimed at everyone involved in using the product and provides directions on how to operate it safely and as intended.

ARRI recommends that all users of the ARRI Impression V Filters read the user manual entirely prior to use. For experienced users, the manual structure also provides quick access for reference.

How to Use This Manual

All illustrations and explanations are based on the perspective of a user who is already familiar with ARRI Signature lenses and the principle of the rear magnetic filter interface of the LPL mount.

All directions are given from a user’s point of view.

Connectors are written in all capital letters, for example, LPL.

This manual contains furthermore useful reference material including the technical specifications and dimensional drawings.

Document Revision History

Version	ID	Release	Date	Description
1.0	D45 10007416		2023-03-23	Initial Release
1.01	D45 10007416	K11228	2023-03-31	LDS shimming modified

1.1 Intended Use

ATTENTION
<p>All versions of the product are intended exclusively for professional use and may only be used by skilled personnel. Every user should read and understand the user manual. Use the product only for the purpose described in this document. Always follow the instructions and system requirements for all equipment involved.</p> <p>ARRI assumes no liability for damages or changes that are caused by improper use.</p> <p>The entire product may not be changed or converted.</p>

2 About this Product

2.1 Introduction

The ARRI Impression V Filters

All ARRI Signature Prime and Signature Zoom lenses are equipped with a built-in rear magnetic filter adapter. Since the launch of the Signature Lenses, this adapter gave cinematographers the chance to craft their own filters and easily attach them to the back of Signature Primes and Signature Zooms.

Featuring the same rear magnetic filter holder concept, Impression V Filters are first in a line of ARRI Impression Filters offering the ability to create a vintage feel to Signature Prime and Zoom lenses. The four negative and four positive diopter filters incrementally shift the focus characteristics of the image, allowing a range of detuned looks to be created for Super 35 or large format with one set of Signature lenses.

Diopters are traditionally positioned in front of a lens to reduce its close focus distance, but ARRI's new Impression V Filters are completely different. Attaching to the back of Signature lenses via the built-in rear magnetic filter adapter, they alter the appearance of out-of-focus as well as the in-focus image elements.



Known as bokeh, these elements play a significant role in the emotional impact of images. All bokeh is affected by the Impression V Filters, but it is particularly noticeable in background highlights, which get more of a 'donut' effect (bright around the edges) with negative filters, and more of a 'bauble' effect (brighter in the middle) with positive filters. In general, the positive filters have a nostalgic, glamorous feel, with swirly bokeh, glowing skin tones, and softer backgrounds; while negative filters have a grittier look, with inward-pulling bokeh and intense, vibrant backgrounds.

The four positive Impression V Filters are named IV 070P, IV 140P, IV 230P, and IV 330P, while the four negative filters are IV 050N, IV 100N, IV 200N, and IV 290N. In both cases, the increasing numbers signify a stronger diopter effect. Impression V Filters are designed to be used at T1.8, where the effect is strongest and lens scales remain accurate. Positive filters attach directly to the rear of each Signature lens without the need for modification. Negative filters require the addition of a shim which is easily installed with minimal training. There is a 2 mm shim for shooting at T1.8, and a 1.85 mm shim to act as a base for the additional shimming required to shoot with Signature Zooms, or at higher stops with Signature Primes.

The filters come in a kit that contains all eight positive and negative diopters, as well as a shim set, an adjustable torque screwdriver for adding shims, and inscribable Velcro® tabs for labeling filtered lenses on set, all packaged in a specially designed aluminum flight case.

For customers who don't need a full kit, or perhaps are replenishing one, each of the eight filter types can be purchased in a separate three-filter set that includes Velcro® tabs and—in the case of the negative filters—a shim set. Velcro® sets and shim sets can also be purchased separately. The ARRI Impression V Shim Pack provides six additional shim sets.

Each ARRI Impression V Shim Set consists of 3x 2mm LPL mount shim, 3x 1.85 mm LPL mount shim and 3x 1.925 mm LDS shim. Furthermore, each shim set contains 24 pieces of special screws TX6 which shall be used for the mounting of the LPL mount. The ARRI Impression V Velcro® Pack, provides additional ARRI Impression V Velcro® Sets. One Impression V Velcro® Set contains 12 Velcro® tabs.

Impression V Filters provide a cost-effective way to deconstruct the digital image and achieve multiple creative looks with just one set of Signature lenses. In this sense they are much more than filters, they are additional optical elements that detune the lenses in a controllable way, whether the goal is to make skin tones even more gentle and forgiving, or to create a particular mood with unusual focus characteristics. They make an entire lens set more versatile and creatively expressive. Productions can craft a detuned look without needing extensive prep time, or they can add a secondary look without hiring a second set of lenses. And rental houses that are not set up for customized internal lens tuning can now offer detuned looks, knowing that they can return the Signature lenses to their original state in minutes.

While the Impression V Filters and shims can be mounted to lenses without requiring a qualified lens technician, ARRI recommends that decisions about which type of filter to use should be made prior to shooting whenever possible. At a stop of T1.8, productions that like the positive look can interchange all four positive filters quickly and easily, and productions that choose the negative look can attach shims in advance and swap between the four negative filters on set. It may also be possible to add or remove shims on set, depending on the crew, the location, and the specific conditions.

As with all ARRI products, Impression V Filters and shims are made to exacting tolerances and the highest standards of precision and quality. Once installed, the lenses will perform as reliably as if they had been built that way in the factory.

Please see the following illustration for a detailed overview of the content which is included in the ARRI Impression V Filter Kit.

2.2 Content of ARRI Impression V Products

ARRI Impression V Filter Kit



- Impression V user manual card
- Screwdriver user manual
- Control certificate
- Optical cleaning cloth
- ARRI Impression V Filter Kit name plate

- Adjustable torque screwdriver with Torx bit TX6x65

- IV Shim Set
- IV Velcro® Set

- IV 070P
- IV 140P
- IV 230P
- IV 330P

- IV 050N
- IV 100N
- IV 200N
- IV 290N

Impression V Velcro® Set



- Includes:
- 12x Velcro® tab

Impression V Shim Set



- Includes:
- 3x LPL Mount Shim (2 mm)
 - 3x LPL Mount Shim (1.85 mm)
 - 3x LDS Shim (1.925 mm)
 - 24x Special TX6 Screws

ARRI Impression V Filter Pack for Positive Filters:

(Example: ARRI Impression V 330P Filter Pack)

Content:

- 3x ARRI Impression V Filter 330P
- 3x ARRI Impression V Velcro® Set (including 12 Velcro® Tabs each)
- Zip lock bag which includes:
 - User manual card
 - Test certificate
 - Optical cleaning cloth



ARRI Impression V Filter Pack for Negative Filters:

(Example: ARRI Impression V 290N Filter Pack)

Content:

- 3x ARRI Impression V Filter 290N
- 1x ARRI Impression V Shim Set
 - Each Shim Set includes:
 - 3x LPL Mount Shim (2 mm)
 - 3x LPL Mount Shim (1.85 mm)
 - 3x LDS Shim (1.925 mm)
 - 24x Special TX6 Screws
- 2x ARRI Impression V Velcro® Set (including 12 Velcro® Tabs each)
- Zip lock bag which includes:
 - User manual card
 - Test certificate
 - Optical cleaning cloth



ARRI Impression V Shim Pack

Content:

- 6x ARRI Impression V Shim Set
 - Each Shim Set includes:
 - 3x LPL Mount Shim (2 mm)
 - 3x LPL Mount Shim (1.85 mm)
 - 3x LDS Shim (1.925 mm)
 - 24x Special TX6 Screws
- Zip lock bag which includes:
 - User manual card
 - Test certificate



ARRI Impression V Velcro® Pack

Content:

- 6 x ARRI Impression V Velcro® Set (including 12 Velcro® Tabs each)
- Zip lock bag which includes:
 - User manual card
 - Test certificate



2.3 Identification of Impression V Products

Each Impression V storage box is equipped with a sticker that provides information about the content within the storage box:



- 1 Identifies whether the storage box contains one of the 8 different filter types or whether it is a Shim or Velcro® Set.
- 2 Global Trade Item Number (GTIN) / Bar code / Data Matrix Code

Identification of Impression V Filter Type

The Impression V filter type is engraved into the filter ring of the rear magnetic filter holder. This can be seen in the image below with the IV 230P filter.



The nomenclature of the filters is as follows:

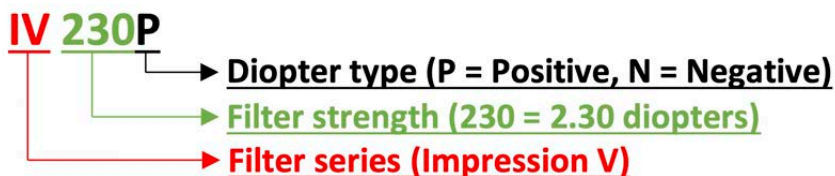

Global Trade Item Number (GTIN)

The product GTIN number is placed on a sticker at the bottom of the filter storage box as clear text, data matrix code and barcode as well following the international GS1 standard. The GS1 barcode or data matrix code can be scanned with appropriate barcode scanners.

The encoded information of ARRI's GS1 GTIN code differs from the usual ARRI product barcode labels.

2.4 Certifications and Safety Standards

ARRI is committed to providing our customers with safe and environmentally friendly products that are compliant with the European Union RoHS and the European Union REACH regulation.

3 Safety Instructions

This safety information is in addition to the product specific operating instructions in general and must be strictly observed for safety reasons. Read and understand all safety and operating instructions before you operate or install the system. Retain all safety and operating instructions for future reference. Always follow the instructions in this and all documents supplied with the device to avoid injury to yourself or others and damage to the system or other objects.

Assembly and operation should only be carried out by trained staff familiar with the system. Only use the tools, materials and procedures recommended in this document. For the correct use of other equipment, see the manufacturer's instructions.

3.1 Safety Conventions and Product Labels

Structure of Safety and Warning Messages

These instructions use safety instructions, warning symbols and signal words to draw your attention to different levels of risk:

⚠ WARNING

WARNING indicates a potentially hazardous situation which, if not avoided, may result in death or serious injury.

- ▶ Always follow the recommended measures to avoid this hazardous situation.

⚠ CAUTION

CAUTION indicates a potentially hazardous situation which, if not avoided, may result in minor or moderate injury.

- ▶ Always follow the recommended measures to avoid this hazardous situation.

ADVICE

ADVICE signifies a potentially hazardous situation which can result in damage to property.

- ▶ Always follow the recommended measures to avoid this hazardous situation.

ATTENTION

Not relevant to safety, **ATTENTION** provides additional information to clarify or simplify a procedure.

Warning Symbols and Product Labels



General warning sign



Warning of electrical voltage



Warning of hot surfaces



Warning of hand injuries



Warning of the risk of crushing



Warning of obstacles on the ground



Please read all instructions carefully before using the product for the first time.



Direct Current symbol found on electronics requiring or producing DC power

3.2 General Safety Instructions

⚠ CAUTION

 **Do not point the lens / camera into direct sunlight, very bright light sources, or high energy light sources (e.g., laser beams)!**
This may damage or destroy a camera sensor and cause additional harm to the camera or lens.

⚠ CAUTION

- Do not remove any safety measures from the system.
- Do not operate the system in areas with humidity above operating levels, expose it to water or moisture!
- Do not subject the lens to severe shocks.
- Never insert objects of any kind into any part of the filter if these are not clearly qualified for the task in the manual.
- Do not remove any paint marked screws.
- Changing filters should be done in a dry and dust-free environment. If this is not possible, take extra care that no dust enters the camera while the lens is off.
- Follow the cleaning instructions in this manual to avoid damage of the filter.
- Do not use any strong or aggressive cleaning detergents like Methanol, Acetone, Benzine, or acids, as they may damage the optical coating or filter mount.

ATTENTION

- Always follow these guidelines to ensure against injury to yourself or others and damage to the system or other objects.
- This safety information is in addition to the product specific operating instructions in general and must be strictly observed for safety reasons.
- Read and understand all safety and operating instructions before you operate or install the system.
- Retain all safety and operating instructions for future reference.
- Read all warnings on the system and in the safety and operating instructions before you operate or install the system. Follow all installation and operating instructions.
- Do not use accessories or attachments that are not recommended by ARRI, as they may cause hazards and invalidate the warranty.
- Do not attempt to repair any part of the system.

4 The Use of ARRI Impression V Filters with ARRI Cameras and Lenses

ARRI Impression V Filters can be attached to the back of all Signature Prime and Zoom lenses via the built-in rear magnetic filter adapter. In addition, the 1.7x Signature Zoom Extender can be used as well. Please see the section below for important information regarding the correct mounting of ARRI Impression V Filters.

4.1 Magnetic Holding System

- 1 Before mounting an Impression V Filter to the back of a Signature Prime or Signature Zoom lens, please make sure that the Magnetic Rear Filter Holder, which is included as a standard part with every Signature lens, is removed.
- 2 Attach an Impression V Filter to the lens by placing the magnetic face of the filter against the rear of the lens until it seats firmly. The rear magnetic filter adapter has 12 magnets which allows for 12 different mounting positions of the filter. However, since all Impression V Filters are rotationally symmetrical, the filters will produce the same effect, regardless of which orientation you choose to attach the filter to the lens. The witness marks on the filter and the mount of the lens are just a reference in case you intentionally want to alter the filter.
- 3 Remove an attached Impression V Filter by lifting it gently from the rear of the lens. No tools are necessary.

⚠ CAUTION

- The lens is designed to be used with an accessory attached, even if it is an empty Magnetic Rear Filter Holder. The only exception applies when using a lens with the 1.7x Extender, in which case the Impression V Filter should be moved to the rear of the 1.7x Extender.
- Be careful not to touch the rear lens when attaching or removing an Impression V Filter of the rear part.
- If the camera is used in a vertical direction pointing upwards with the Signature lens and the Impression V Filter attached, the filter may fall off the Magnetic Rear Filter Adapter in case strong shaking movements or shocks are applied. This could result in damage to the filter.
- It is not possible to stack multiple Impression V Filters.

4.2 The Use of Impression V Filters with 1.7x Zoom Extender

Remove the Magnetic Rear Filter Holder or the Impression V Filter from the rear of the lens. Transfer the ARRI Impression V Filter to the rear of the 1.7x Signature Zoom Extender.

⚠ CAUTION

Failure to remove the Magnetic Rear Filter Holder or Impression V Filter from the lens will prevent the lens from seating properly and may damage the lens, the 1.7x Zoom Extender, and the filter element.







Attach the rear of the lens to the front of the 1.7x Extender. Ensure that the lens is firmly seated, and the alignment pin is properly engaged before rotating the LPL locking ring to the closed position. If the LPL locking ring does not close, DO NOT FORCE. Ensure that the Magnetic Rear Filter Holder has been removed. Mount the lens and 1.7x Extender to the camera, making sure that the lens support is in place and roughly positioned.

To remove, reverse this procedure and transfer the Magnetic Rear Filter Holder or Impression V Filter from the rear of the 1.7x Extender to the rear of the lens.

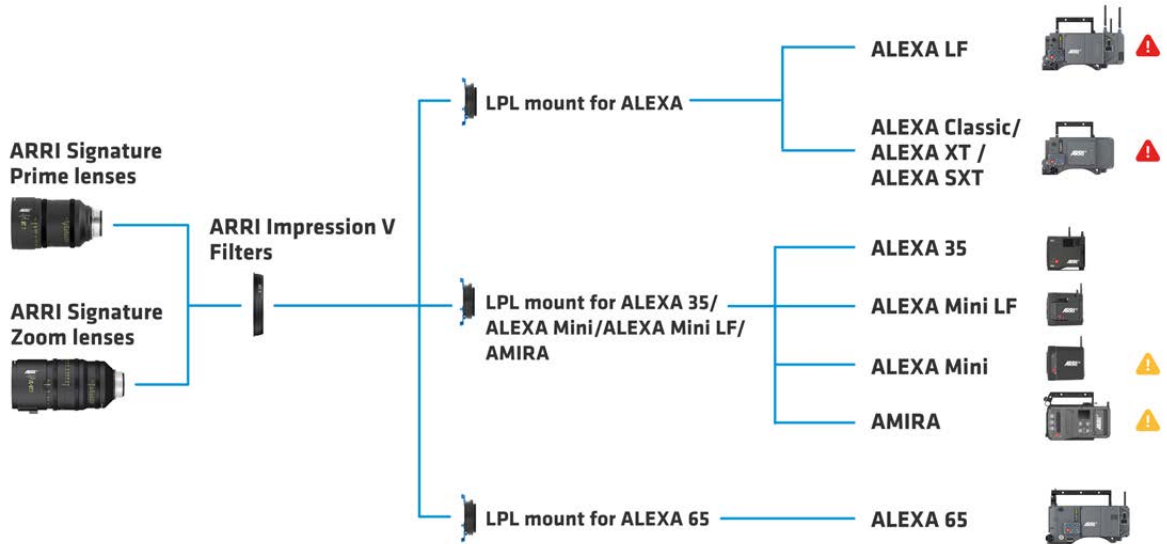
4.3 Compatibility Information

As illustrated in the compatibility chart below, ARRI Impression V Filters can basically be used with all ARRI camera systems. However, for some camera models important precautions must be taken to ensure compatibility.



-  A Signature lens with an attached Impression V filter can only be mounted to an ALEXA LF or ALEXA Classic / ALEXA XT / ALEXA SXT if the In-Camera Filter Module (IFM) is removed from the LPL Mount.
-  A Signature lens with an attached Impression V filter can only be mounted to an ALEXA Mini or AMIRA if the camera has been converted for use with Leica M-Mount lenses. For further information regarding the conversion, please contact an ARRI service center.
-  The compatibility of 3rd party cameras and adapters needs to be checked.

ALEXA 35, ALEXA Mini LF & ALEXA 65

No adjustments are needed. A Signature lens with an attached Impression V Filter can be mounted to the camera without any concerns.

ALEXA LF, ALEXA Classic, ALEXA XT, ALEXA SXT

It is important to verify whether the filter position in the LPL lens mount is occupied by the LF IFM Filter Frame. A Signature lens with an attached Impression V Filter can only be mounted to the camera if the filter frame is removed. Please see chapter 4.3.1 and 4.3.2 for a detailed explanation on how to remove and insert the in-camera filter of the LPL Mount for ALEXA cameras.

⚠ CAUTION

Failure to remove the in-camera filter from the LPL lens mount will prevent the lens from seating properly and may damage the in-camera filter and the Impression V Filter.

ALEXA Mini, AMIRA

A Signature lens with an attached Impression V Filter can only be mounted to an ALEXA Mini or AMIRA if the camera has been converted for use with Leica M-Mount lenses. For further information regarding the conversion, please contact the ARRI service center.

⚠ CAUTION

A use of an ALEXA Mini or AMIRA which is not converted for use with Leica M-Mount lenses will prevent the lens from seating properly and may damage the Impression V Filter.

5 Handling of In-camera Filter of LPL Mount for ALEXA

5.1 Removal of In-camera Filter

- 1 Remove the lens or lid (1) from the LPL lens mount (2).

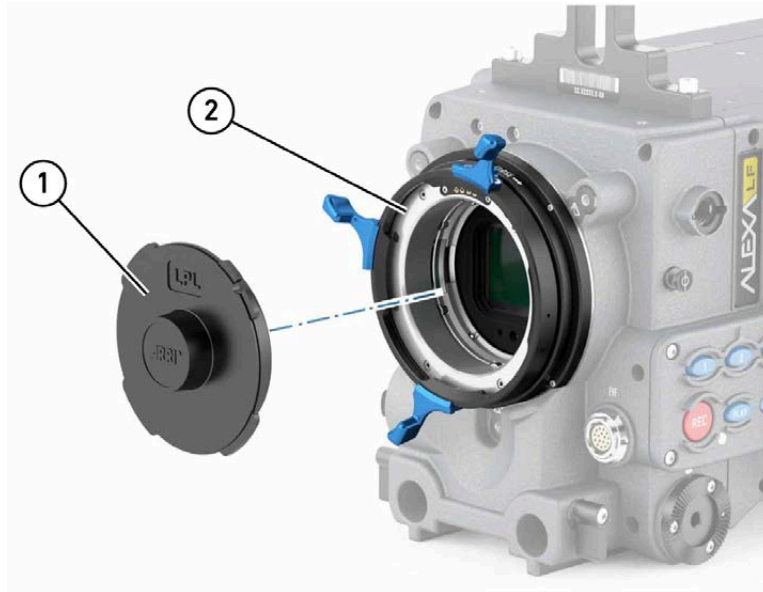

- 2 Carefully screw the filter insertion tool (1) into the filter ring's (2) thread hole in the 12 o'clock position (1).

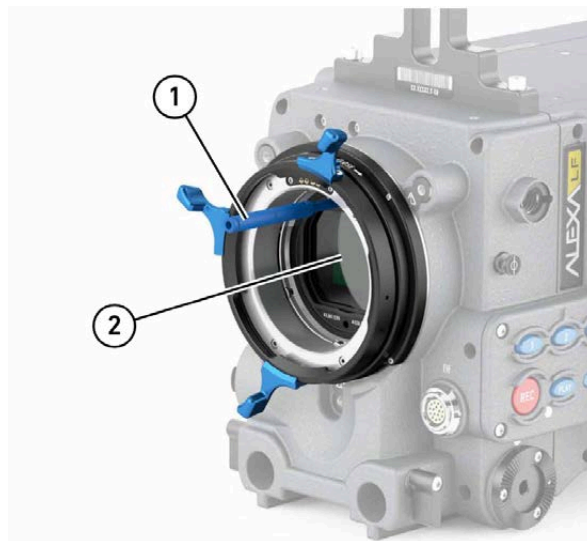

- 3 Pull the filter (2) from the bottom ring in the camera's LPL mount. If the filter position is held by an LF IFM Empty Filter Frame, remove it likewise.

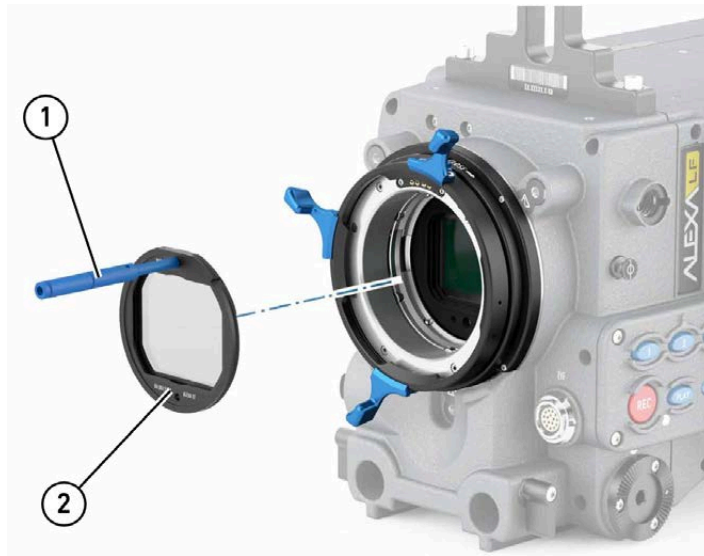

- 4 Clean the removed filter and stow it properly in its individual box and the storage case. If the filter position was held by an LF IFM Empty Filter Frame, store it likewise.
- 5 Place the removed filter into its padded filter box in the storage case. Remove the filter insertion tool.

5.2 Insertion of In-camera Filter

- 1 Make sure the filter (2) is clean and the filter insertion tool is in the 12 o'clock position (1).

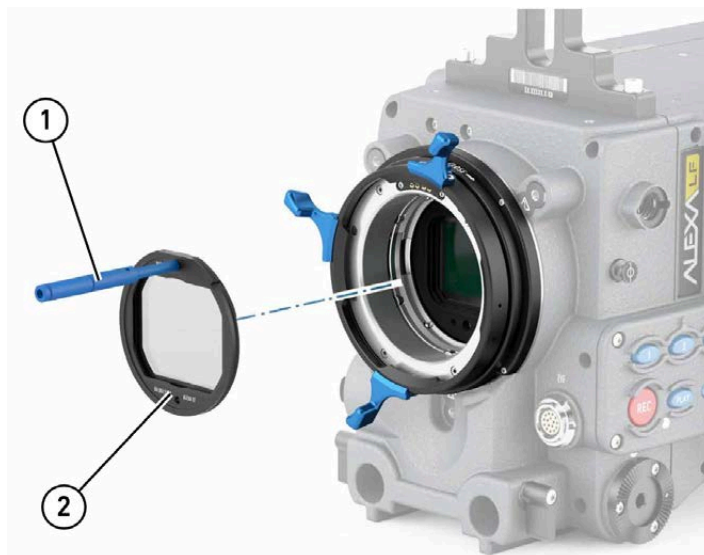

- 2 Place the next filter onto the bottom ring in the camera's LPL mount. The filter insertion tool must be in the 12 o'clock position (1).

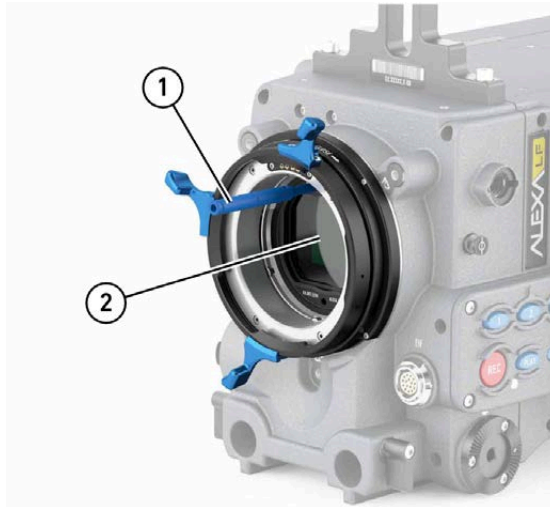

- 3 Align the filter ring's main notch with the bottom ring's red nut in the 6 o'clock position. To ensure an accurate fit, align the filter ring's other notches with the two red noses in the bottom ring's 10:30 and 1:30 positions.
- 4 Put your finger on the lower edge of the filter ring and push the filter ring slightly inwards, using the filter insertion tool on top and your finger on the bottom.
- 5 After the filter ring has audibly snapped into position, carefully unscrew the filter insertion tool. The filter must sit precisely on the bottom ring.
- 6 Mount a lens (observe maximum lens dimensions!) or cover the LPL lens mount properly with its lid.

6 Optical Properties

Focal length, image circle and T-stop change

When using the Impression V Filters with Signature Primes and Zooms, some basic parameters of the lens system will change. Like a „weak extender“, the focal length of the base lens as well as the size of the projected image and the aperture will change. The factors are given in the following table.

	Focal Length multiplier	Image circle multiplier	T-stop multiplier	Exposure change (stops)	Open aperture for T1.8 lens
IV 290N	1.068	1.068	1.068	-0.19	1.92
IV 200N	1.050	1.050	1.050	-0.14	1.89
IV 100N	1.027	1.027	1.027	-0.08	1.85
IV 050N	1.015	1.015	1.015	-0.04	1.83
No Filter	1.000	1.000	1.000	0.00	1.80
IV 070P	0.980	0.980	0.980	0.06	1.76
IV 140P	0.968	0.968	0.968	0.09	1.74
IV 230P	0.950	0.950	0.950	0.15	1.71
IV 330P	0.929	0.929	0.929	0.21	1.67

Hereinafter you will find an exemplary calculation of the influenced optical parameters based on the following lens configuration:

- Lens: Signature Prime 35 mm @ T1.8
- Impression V Filter: IV 230P

The results when using the lens configuration from above is as follows:

- Resulting Focal length: $35 \text{ mm} * 0.95 = 33,25 \text{ mm}$
- Resulting T-Stop: $T1.8 * 0,95 = T1.71$

7 Required Shimming Depending on T-Stop

7.1 Shimming of LPL Mount

⚠ CAUTION								
<ul style="list-style-type: none"> When removing the LPL mount you will find the previously installed shims underneath. It is advisable to mark these shims to make returning to the original configuration easier. The pre-installed shims must remain on the lens. If Impression V Filters are used in combination with a 1.7x Extender, please make sure to shim the mount of the 1.7x Extender instead of the LPL mount of the lens. 								

T-stop	Negative Diopter Filters				Positive Diopter Filters			
	IV050N	IV100N	IV200N	IV290N	IV070P	IV140P	IV230P	IV330P
T1.8	2 mm				Shimming not necessary			
T2.0	1.85 + 0.14	1.85 + 0.13	1.85 + 0.13	1.85 + 0.14	/	0.025	0.025	/
T2 1/3 (T2.24)	1.85 + 0.125	1.85 + 0.125	1.85 + 0.125	1.85 + 0.13	0.025	0.03	0.03	0.025
T2 2/3 (T2.5)	1.85 + 0.1	1.85 + 0.1	1.85 + 0.1	1.85 + 0.125	0.025	0.05	0.05	0.025
T2.8	1.85 + 0.1	1.85 + 0.08	1.85 + 0.08	1.85 + 0.1	0.03	0.06	0.06	0.03
T4.0	1.85 + 0.09	1.85 + 0.07	1.85 + 0.05	1.85 + 0.07	0.04	0.08	0.1	0.09
T4.95	1.85 + 0.08	1.85 + 0.06	1.85 + 0.04	1.85 + 0.05	0.05	0.09	0.1	0.1
T5.6	1.85 + 0.08	1.85 + 0.06	1.85 + 0.04	1.85 + 0.05	0.05	0.09	0.1	0.1

All given shim thicknesses are in mm

Use of ARRI Impression V Filters at a T-stop of T1.8:

- Shimming for the use of **negative** Impression V Filters:
Please use the LPL mount shim **2 mm** which is provided in the Impression V Shim Set. No individual shims are required. All different negative filter types (IV 050N, IV 100N, IV 200N, IV 290N) can be used without the need for re-shimming.

Use of ARRI Impression V Filters at a T-stop other than T1.8:

- Shimming for the use of **negative** Impression V Filters:
For each T-stop / filter type configuration, the table states two values. The first value refers to the LPL mount shim **1.85 mm** which is provided in the Impression V Shim Set. This shim shall be used as a base for each T-stop / filter type configuration. The second value refers to the required thickness of individual shims.
- Shimming for the use of **positive** Impression V Filters:
Please only add individual shims according to the thicknesses mentioned in the table above (no LPL mount shim **1.85 mm** is required!)

ATTENTION

Please note that the shim thicknesses shown in this table are averaged values based on a preselected number of measured reference lenses. Even though all Signature lenses as well as all Impression V Filters are manufactured to highest quality standards with minimal manufacturing tolerances, the shim thicknesses might vary slightly depending on which lens is used.

7.2 Lens Metadata and Shimming of LDS Contact Block

If only the LPL mount shim 2 mm or the LPL mount shim 1.85 mm is used without any further individual shims, the lens will pass meta data when the provided LDS shim 1.925 mm is used.

However, if the lens is shimmed individually for the use at T-stops other than T1.8, in some cases an individual 0.1 mm LDS shim needs to be applied to ensure a stable connection between the LDS terminals of the lens mount and the LDS terminals of the LPL mount. The recess of the LDS contact block from the mount surface must have a gap of maximum 0,3 mm (see image below). If this is not the case, no LDS data will be transferred from the lens to the camera!



The table below gives an overview in which cases LDS shims need to be attached to the LDS contact block and in which cases no shimming is required.

T-stop	Negative Diopter Filters				Positive Diopter Filters			
	IV050N	IV100N	IV200N	IV290N	IV070P	IV140P	IV230P	IV330P
T1.8	1.925 mm LDS Shim (part of Impression V Shim Set)				/	/	/	/
T2.0					/	/	/	/
T2 1/3 (T2.24)					/	/	/	/
T2 2/3 (T2.5)					/	/	/	/
T2.8					/	/	/	/
T4.0					/	0.1 mm LDS Shim		
T4.95					/			
T5.6					/			

7.3 Shimming Tools

Impression V Shim Set



Adjustable torque screwdriver with Torx bit TX6x65



Individual Shims (in case Impression V Filters shall be used at a T-stop other than T 1.8)



- 3x LPL Mount Shim (2 mm)
- 3x LPL Mount Shim (1.85 mm)
- 3x LDS Shim (1.925 mm)
- 24x Special TX6 Screws



Included in all ARRI Impression V Filter Packs containing negative filters:

- ARRI Impression V 050N Filter Pack
- ARRI Impression V 100N Filter Pack
- ARRI Impression V 200N Filter Pack
- ARRI Impression V 290N Filter Pack



Included in ARRI Impression V Filter Kit

Individual shims need to be purchased separately. Please see the material numbers listed below:



LPL-Mount Shims:

50.0020238 - Shim Set*:

Includes:

- 50.0019928, Shim 0.025 mm
- 50.0019923, Shim 0.03 mm
- 50.0019925, Shim 0.04 mm
- 50.0019926, Shim 0.05 mm
- 50.0019929, Shim 0.1 mm
- 50.0019920, Shim 0.2 mm
- 50.0019924, Shim 0.3 mm

*Each shim type can be ordered separately as well.

LDS-Shim:

K5.59474.0,
LDS Shim 0.1 mm

7.4 The Use of the Torque Screwdriver

1 Insertion of the bit into the bit hole of the screwdriver

Remove the screwdriver and bit from the ARRI Impression V Filter aluminum case.



Mount the bit into the end of the screwdriver, ensuring that the bit is fully inserted.



2 Adjustment of the correct torque:

Hold the fluted part of the adjusting ring with your fingers and turn the locking ring counterclockwise to unlock it.

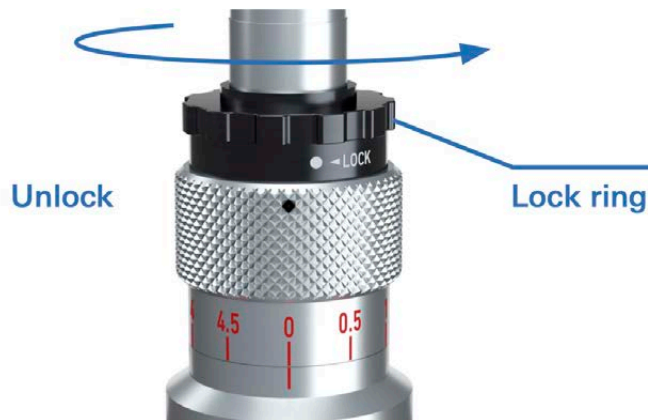

The unit of the torque is displayed in centinewton meter (cN*m). The required torque values you need to set to tighten the screws of the LPL mount and the LDS contact block are listed below. They are repeated inside the upper lid of the box of the Impression V Shim Set.

	Unit	
	N*m	cN*m
LPL Mount LDS contact block	0.1 Nm	10 cNm
LPL Mount	0.5 Nm	50 cNm

Turn the adjusting ring to set the torque value. The torque value of the screwdriver can be calculated the following way:

Torque value = Value of main scale + value of adjusting ring scale

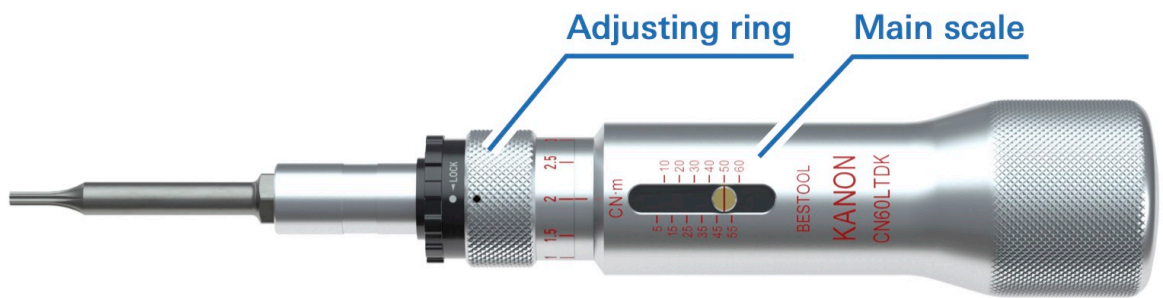

The screwdriver displayed above shows the following torque:

Torque value = 50 cNm + 2 cNm = 52 cNm (0.52 Nm)

Hold the adjusting ring with your fingers and turn the locking ring clockwise to fix the torque value.



- 3 Correct use of the torque screwdriver:
Align the shank axis of the screwdriver with the axis of the screw before tightening.

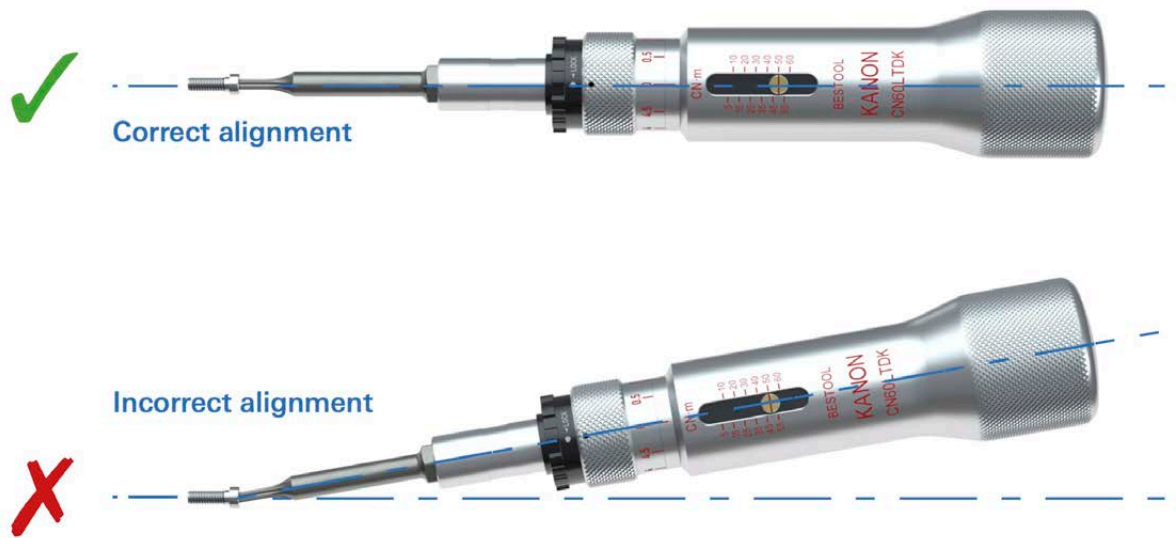

Hold the handle firmly and turn the screwdriver clockwise to tighten the screws completely. Tightening is complete when the screwdriver slips, and you feel a click and hear a click sound. The torque value will not change even if you continue to turn the driver to let it slip again.

4 Removal of the bit from the screwdriver:

Hold the main body of the screwdriver with one hand and pull the bit out of the bit hole of the screwdriver with the other hand.

7.5 Shimming Procedure

- 1 Remove the rear lens cap.
- 2 Remove the LPL mount:
 - a) Use the adjustable torque screwdriver to remove the 8 torx screws of the LPL mount.
 - b) Carefully lift the mount from the lens.

⚠ CAUTION

The 2 mm and 1.85 mm shims require screws that are longer than those that ship with the lens. Replace them with the long screws included in the shim set when using 2 mm and 1.85 mm shims. If this is not carried out with the long screws, the remaining length of the thread becomes too short and leads to an increased instability of the attached mount on the lens.

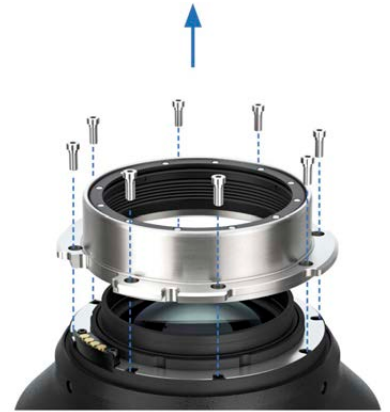

- 3 Select the correct LPL mount shim(s) depending on the T-stop and the filter which shall be used. Please see the table in chapter 7.1 for further information regarding required shim thicknesses.
- 4 Add the appropriate LPL mount shim(s) to the lens and carefully slide the mount back to the lens.

⚠ CAUTION

Ensure that the shims do not cover the screw holes, otherwise they will be damaged by the screws.

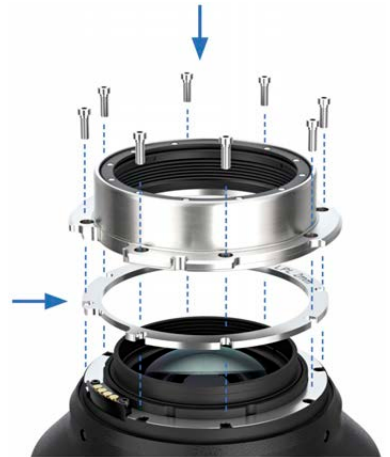

- 5 Please be aware that for tightening the screws a special torque of **0.5 Nm / 50 cNm** must be applied.

Use the adjustable torque screwdriver to tighten the 8 TX6 screws of the LPL mount.

⚠ CAUTION

Please use the provided special screws TX6 for this procedure. Applying the wrong torque can damage the lens!
Make sure that you always tighten opposite screws instead of tightening in a sequence.



6 Use the adjustable torque screwdriver to remove the 2 torx screws of the LDS contact block.

⚠ CAUTION

- You will find the previously installed shim underneath. It is advisable to mark this shim to make returning to the original configuration easier. The pre-installed shim must remain on the lens.
- If Impression V Filters are used in combination with a 1.7x Extender, please make sure to shim the mount of the 1.7x Extender instead of the LPL mount.
- Please note that these screws shall be used for re-assembly when the LDS shim is attached.



7 Add the appropriate LDS shims to the lens.

⚠ CAUTION

Handle the thinner shims particularly careful as they can easily kink or tear which makes them unusable.

Ensure that the shims do not cover the screw holes, otherwise they will be damaged by the screws.



8 Tighten the LDS contact block. Please be aware that for tightening the screws a special torque of **0.1 Nm / 10 cNm** must be applied.

Use the adjustable screwdriver to tighten the 2 torx screws of the LDS contact block.

⚠ CAUTION

Applying the wrong torque can damage the LDS contact block!
Please use the existing screws of the LDS contact block for this procedure.



8 The Use of Velcro® Tabs

Each Impression V Filter Kit as well as all Impression V Filter Packs contain one or more Velcro® sets. The purpose of these Velcro® fasteners is to easily identify filtered lenses on set without the need to remove the lens from the camera. This makes it possible to always track which of the 8 different filter types is attached to the rear magnetic filter adapter of your Signature Prime or Signature Zoom lens.

In general, a Velcro® tab fastener consists of two linear fabric strips which are attached to opposite surfaces to be fixated: one strip is called a hook and the other strip is called the loop fastener.

Hook:

The surface of the hook can be recognized by its rough side featuring lots of tiny hooks. The facing side of the hook is coated with a white rigid polyvinyl chloride (PVC) film. Imprinted with an ARRI logo, this film can be used for inscribing the Velcro® tab.

Loop:

The surface of the loop can be recognized by its soft side featuring lots of tiny loops. The facing side of the loop contains a tape which is covered with a protective film and shall be used to glue the loop on the desired surface.



Below you will find a description of how to attach, label and clean the Velcro® tab properly.

8.1 To Attach Velcro® Tabs

- 1 Clean and dry the surface before attaching the tape on the desired surface. Wipe down the surface with a detergent that doesn't leave a film or an oily residue. Otherwise, this may affect the Velcro's ability to adhere. An effective way to clean the surface without leaving behind residues is the use of isopropyl alcohol wipes.

▲ CAUTION

Avoid caustic cleaning agents such as Methanol, Acetone, Benzine, or acids as they may damage the lens barrel!

- 2 Peel off the protective film of the loop and press the tape firmly onto the desired surface. Be careful not to touch the sticky side as this might affect the adhesiveness of the Velcro®.
- 3 You can attach the hook of the Velcro® strip onto the loop right away. Just keep in mind that the Velcro® adhesive base needs 24 hours to achieve its strongest adhesion. If you are concerned about the glue coming loose, wait at least one day before attaching and removing hooks from the loop.

▲ CAUTION

- Self-adhesive Velcro® strips don't stick as well when you peel them off and try to reuse them.
- Please note that these tapes are not recommended for fabrics, dashboards, flexible vinyl or use underwater. Continued exposure to full sunlight can also damage the fastener.

8.2 To Label and Clean Velcro® Tabs

The surface of the Velcro® consists of a white rigid polyvinyl chloride (PVC) film and can be inscribed with a water-soluble pen. However, to ensure good legibility, the use of a whiteboard marker is recommended. Such a labeling can be seen in the illustration below. The Velcro® tab which is attached to the barrel of the Signature Prime 47 mm is labeled for the use with an Impression V 330P filter. The surface can be cleaned by using isopropyl alcohol wipes.



⚠ CAUTION

If the surface is inscribed with a permanent marker, it may no longer be possible to clean it completely.

8.3 To Remove a Velcro® Tab

- 1 Detach the hook from the Velcro® tab.
- 2 Pull the corner of the loop up as much as possible with one hand, while holding the lens to which the loop is attached with your other hand.
- 3 Take the corner of the loop and slowly pull it off the lens from top to bottom.
- 4 Clean the surface with the help of isopropyl alcohol wipes to ensure that no residues are left behind.

⚠ CAUTION

Avoid caustic cleaning agents such as Methanol, Acetone, Benzene, or acids as they may damage the lens barrel!

9 Cleaning

ARRI Impression V Filters are precision optics carefully designed to meet the demanding artistic and technical needs of cinematographers at every level of production. For optimal and predictable results, it is crucial to keep your optics clean. Depending on the environment, dust, and non-volatile residuals from cleaning agents, etc., may deteriorate the optical performance significantly. Although the optical coatings of the ARRI Impression V Filters have been designed to be robust, it is recommended to follow the common rules of handling precision optics proposed in this manual.

⚠ CAUTION

- Avoid touching optical surfaces!
- Apply blown air to optical surfaces prior to dusting. Deionized air will improve dusting efficiency if particles or optical surfaces are electrostatically charged.
- Avoid compressed air from cans as droplets of propellant may contaminate optical surfaces and prove difficult to remove. Use oil-free compressed air with less than 2 atm of pressure and equipped with a particle filter in a clean environment.
- Avoid wiping optical surfaces with a dry tissue or cloth. Use a damp cloth with an appropriate cleaning agent (see below).
- Use clean, lint-free, and soft single-use paper-based optics cleaning tissues/pads or ARRI Optics Cleaning Cloth (Small 170 x 150mm, Order Number: 50.0019066; Large 14.6" x 17.7", Order Number: K2.0016922). Avoid abrasive particle contamination of your cleaning supplies and cloths (e.g., by sand).
- Always wipe gently in a single direction and take a new tissue for each stroke if using disposable tissues.

ADVICE

- Have your equipment ready before starting the cleaning process.
- To determine the level of contamination, use a bright lamp or bright daylight and change the angle of view of the surfaces from normal to grazing incidence.
- Always clean the barrel surface or the frame/mount first.
- When cleaning mounted optics or frames, avoid that cleaning agents are drawn into narrow spaces near the retaining rings, etc., due to capillary forces. Use moistened, but not soaking wet tissues.
- Use manual air blowers and clean antistatic brushes.
- Place the filter on a clean, soft surface or a clean ARRI Optics Cleaning Cloth.
- It may be difficult to clean an optical surface without streaks and non-volatile residues when the relative humidity exceeds 65%.
- Always store your filters in the provided cases when not in use. If not stored in a container, store the lens in a clean environment and protective covers on to limit contamination.

9.1 Recommended Cleaning Agents

Use cleaning agents suitable for dielectric coated precision optics to avoid streaking, non-volatile residues, or damaging optical elements. Prepare three different liquids in spray or drop dispensing bottles:

- A neutral window detergent.
- Deionized distilled water.
- Spectroscopy grade isopropyl alcohol.

Always use these liquids in this sequence when cleaning.

9.2 Cleaning Procedure

For minor particle contaminants like dust, pollen, rain residuals, etc., and moderate contaminants like fingerprints or comparable strains:

- 1 Treat the surface with compressed air to remove dust and lint.
- 2 If the surface is still not clean, gently brush off residual loose contaminants.
- 3 Use one dedicated tissue/cloth for each liquid: one for neutral window detergent, one for deionized distilled water, and one for spectroscopy grade isopropyl alcohol. The liquids should be used in this sequence.
- 4 Using a bright light source, check for cleaning agent residues, streaks, or other contaminants. It is common to breathe carefully on the optical surface and then to gently wipe off the condensed moisture with a soft cloth, e.g., a clean ARRI Optical Cleaning Cloth. If you decide to do so, avoid saliva droplets on the surface and do not firmly wipe dry parts of the optical surface. If the surface is still not clean, repeat the cleaning sequence.

9.3 Cleaning Procedure for Aluminum Case

Aluminum Impression V Filter Kit cases can be cleaned using the following methods:

- 1 Light stains, finger smudges and water droplets may be removed using a dry cloth.
- 2 Oil and mud stains may be removed using a mixture of mild detergent and water applied with a damp cloth. Finish with a dry cloth.
- 3 Never use chemical solvents or solutions such as paint thinner, alkaline electrolyzed water, etc.

10 Transportation and Storage

ADVICE



Improper Packing and Transportation of the Impression V Filter Kit

Risk of damage to the Impression V Filter Kit.

- ▶ Follow the specified environmental conditions.
- ▶ Only transport the Impression V Filter Kit in suitable cases.
- ▶ Follow the instructions for transport and storage in this chapter.

The Impression V Filter Kit can be damaged if not transported and stored properly. Please take note of the following guidelines.

ADVICE



Improper Handling of the Impression V Filter Kit

Risk of damage to the Impression V Filter Kit.

- ▶ Keep the Impression V Filter off the lens when not mounted to the camera or not in operation to prevent the filter from falling off.
- ▶ To properly attach the rear lens cap to the mount, the Impression V Filter must first be removed from the lens. With this procedure it is ensured that the Impression V Filter is not forgotten on the rear side of the lens.
- ▶ Exposing the filters to direct sunlight may cause the sun's rays to focus on a surface that may ignite

Transportation Guidelines:

- Always store the filters and the accompanying accessories in the provided storage boxes.
- The ARRI Impression V Filter Kit is delivered in a rugged aluminum case. A lock can be used on the latches of the case to secure the case. The case should always be used when shipping the Impression V Filter Kit.
- Do not submerge the case in water.

Storage Guidelines:

- Do not store the filters for long periods of time in places where it may be subject to extreme temperatures, direct sunlight, high humidity, severe vibration, or strong magnetic fields.
- When moving the lens and the filter from a cool to a warm location or when they are used in a damp environment, condensation may form inside the lens port, on glass surfaces, and on internal or external electrical connections. Operating the lenses and filters while condensation is present may result in damage to the equipment. Condensation on the optical components may have a visible effect on the output images. To reduce the risk of condensation, find a warmer storage location. After moving the lens and the filters from cool to warm environment, wait for some time for the lens and filters to warm up to the ambient temperature to avoid condensation.

10.1 Aluminum Case

ARRI recognizes that our lens and filter products are significant long-term investments. ARRI lens & filter cases are designed to protect your investments while remaining practical for everyday use.

Aluminum Case

Case XS for ARRI Impression V Filter Kit



Latching and Unlatching

- A “U” protector surrounds each latch to protect against side impacts that may damage the mechanism and cause it to loosen.
- Each latch is equipped with a safety lock to prevent the latch from opening accidentally.
- To open a latch, start by locating the safety lock release studs on either side of the latch lever. Grasp and pull down on the release studs while lifting the latch lever to the open position. As the latch hook extends, move it free of the catch.
- To close a latch, place the latch hook over the catch on the case lid. Lower the latch lever until the latch hook is firmly captured and the latch lever is flush to the case.
- For additional protection against accidental latch release, thread a cable lock or zip tie through the holes in the “U” protector and the base of the latch lever and secure.



Foam Insert Protection

Every ARRI case is lined with a two-layer foam insert. A hard foam interior layer holds the contents firmly in place while a soft foam exterior layer absorbs and distributes impact forces.

10.2 Storage Boxes

The storage boxes for the Impression V Filters, as well as for the Impression V Shim Set and Velcro® Set all have the same size and opening mechanism. The storage boxes are covered with a sticker indicating the content of the box. Furthermore, all boxes contain a frame on the lid which makes it possible to easily stack different filter boxes.



All boxes dedicated for the storage of Impression V Filters contain a foam inlay to ensure the save positioning of the filter during transportation. The foam inlay also contains recesses designed to make it easier to remove the filters from the storage box. When inserting the filter in the box, please make sure that the magnetic contacts of the Impression V Filter are facing upwards to insure maximum stability during transportation.



The box for the Impression V Shim Set also includes a foam insert. However, it is different from the foam insert of the filter storage boxes. The foam inlay is recessed to ensure a stable hold of the various LPL mount shims and it contains recesses to make it easier to remove the shims from the storage box. As shimming has to be performed with different torques you can find an overview of the necessary torques inside the lid.



Please note that the box designed for the storage of Velcro® tabs doesn't contain a foam inlay.

11 ARRI Impression V Product Range

ARRI Impression V Filter KitKK.0048312

Includes:

- 1x ARRI Impression V Aluminum Case
- 1x ARRI Impression V Filter 070P
- 1x ARRI Impression V Filter 140P
- 1x ARRI Impression V Filter 230P
- 1x ARRI Impression V Filter 330P
- 1x ARRI Impression V Filter 050N
- 1x ARRI Impression V Filter 100N
- 1x ARRI Impression V Filter 200N
- 1x ARRI Impression V Filter 290N
- 1x ARRI Impression V Shim Set
- 1x ARRI Impression V Velcro® Set
- 1x Torque Screwdriver



ARRI Impression V 070P Filter PackK2.0048139

Includes:

- 3x ARRI Impression V Filter 070P
- 3x ARRI Impression V Velcro® Set



ARRI Impression V 140P Filter PackK2.0048140

Includes:

- 3x ARRI Impression V Filter 140P
- 3x ARRI Impression V Velcro® Set



ARRI Impression V 230P Filter PackK2.0048141

Includes:

- 3x ARRI Impression V Filter 230P
- 3x ARRI Impression V Velcro® Set



ARRI Impression V 330P Filter PackK2.0048142

Includes:

- 3x ARRI Impression V Filter 330P
- 3x ARRI Impression V Velcro® Set



ARRI Impression V 050N Filter PackK2.0048143

Includes:

- 3x ARRI Impression V Filter 050N
- 1x ARRI Impression V Shim Set
- 2x ARRI Impression V Velcro® Set



ARRI Impression V 100N Filter PackK2.0048144

Includes:

- 3x ARRI Impression V Filter 100N
- 1x ARRI Impression V Shim Set
- 2x ARRI Impression V Velcro® Set



ARRI Impression V 200N Filter PackK2.0048145

Includes:

- 3x ARRI Impression V Filter 200N
- 1x ARRI Impression V Shim Set
- 2x ARRI Impression V Velcro® Set



ARRI Impression V 290N Filter PackK2.0048146

Includes:

- 3x ARRI Impression V Filter 290N
- 1x ARRI Impression V Shim Set
- 2x ARRI Impression V Velcro® Set



ARRI Impression V Shim PackK2.0048147

Includes:

6x ARRI Impression V Shim Set



ARRI Impression V Velcro® PackK2.0048148

Includes:

6x ARRI Impression V Velcro® Set



12 ARRI Service Contacts

Please see the current list of service partners at [Service contacts](#)



**Arnold & Richter Cine Technik
GmbH & Co. Betriebs KG**
Herbert-Bayer-Str. 10
80807 Munich
Germany
+49 89 3809 2121
Business hours:
Mo. - Fr. 09:00 am - 05:00 pm (CET)
service@arri.de

ARRI Inc. / West Coast
3700 Vanowen Street
CA 91505 Burbank
USA
+1 818 841 7070
Business hours:
Mo. - Fr. 09:00 am - 05:00 pm (PT)
service@arri.com

ARRI Canada Limited
1200 Aerowood Drive, Unit 29
ON L4W 2S7 Mississauga
Canada
+1 416 255 3335
Business hours:
Mo. - Fr. 08:30 am - 05:00 pm (EDT)
service@arri.com

ARRI Asia Pte. Ltd.
164 Kallang Way, #03-01
349248 Singapore
Singapore
+65 6230 9488
Business hours:
Mo. - Fr. 9:00 am - 06:00 pm (CST)
service@arri.asia

ARRI CT Limited / London
2 Highbridge, Oxford Road
UB8 1LX Uxbridge
United Kingdom
+44 1895 457 000
Business hours:
Mo. - Thu. 09:00 - 17:30
Fr. 09:00 am - 05:00 pm (GMT)
service@arri-ct.com

ARRI Inc. / East Coast
617 Route 303
NY 10913 Blauvelt
USA
+1 845 353 1400
Business hours:
Mo. - Fr. 08:00 am - 05:30 pm (EST)
service@arri.com

ARRI Australia Pty Ltd
Suite 2, 12B Julius Ave
NSW 2113 North Ryde
Australia
+61 2 9855 4305
Business hours:
Mo. - Fr. 08:00 am - 05:00 pm (AEST)
service@arri.com.au

ARRI China (Beijing) Co. Ltd.
Chaowai SOHO Tower C, 6/F, 0628/0656
Chaowai Dajie Yi 6
Beijing
China
+86 10 5900 9680
Business hours:
Mo. - Fr. 09:00 am - 06:00 pm (CST)
service@arri.cn

ARRI Hong Kong Limited

41/F One Kowloon, 1 Wang
Yuen Street Kowloon Bay
Hong Kong
China
+852 2537 4266
Business hours:
Mo. - Fr. 09:00 am - 06:00 pm (CST)
service@arri.asia

ARRI Japan Kabushiki Kaisha

Service
Haneda Innovation City Zone K210, 1-1-4
Hanedakuko, Ota-Ku
144-0011 Tokyo
Japan
+81 3 6635 3750
Business hours:
Mo. - Fr. 10:00 am - 06:00 pm (JST)
info@arri.jp

CINEOM Broadcast DMCC.

Unit No. 2109, Jumeirah Bay Tower X2 Cluster X
Jumeirah Lakes Towers
P.O Box 414659
Dubai, UAE
+971 (0) 45570477
Business hours:
Sa. - Th. 10:00 am- 06:00 pm
arriservice.me@cineom.com

LINKA İthalat İhracat ve Dış Tic.

Distributor
Halide Edip Adivar Mah. Darülaceze Cad.
No:3 Akın Plaza Kat:5 95-96
34381 Şişli, İstanbul
Turkey
+90 2123584520
Business hours:
Mo. - Fr. 09:00 am - 06:00 pm (EET)
service@linkgroup.com.tr

ARRI Korea Limited

Kolon Digital Tower 1(#1505-06), 25
Seongsuil-ro 4 gil, Seongdong-gu
04781 Seoul
Korea
+82 (0)70 4419 6401
Business hours:
Mo. - Fr. 9:00 am - 06:00 pm (KST)
service@arri.kr

ARRI Brasil Ltda

Avenida Ibirapuera 2907 – Cj. 421, Indianópolis
04029-200 São Paulo
Brazil
+55 1150419450
Business hours:
Mo. - Fr. 09:00 am - 05:30 pm (BRT)
arribrasil@arri.com

CINEOM Broadcast India Pvt. Ltd.

C-4, Goldline Business Centre
Link Rd. Malad West
400 064 Mumbai
India
+91 (0)22 42 10 9000
Business hours:
Mo. - Sat. 10:00 am - 06:00 pm (IST)
arrisupportindia@cineom.com

13 Dimensional Drawings

ARRI Impression V Filters



IMPRESSION V FILTERS DIMENSIONS – Version 2023-03

Technical Data are subject to change without notice.

Overview

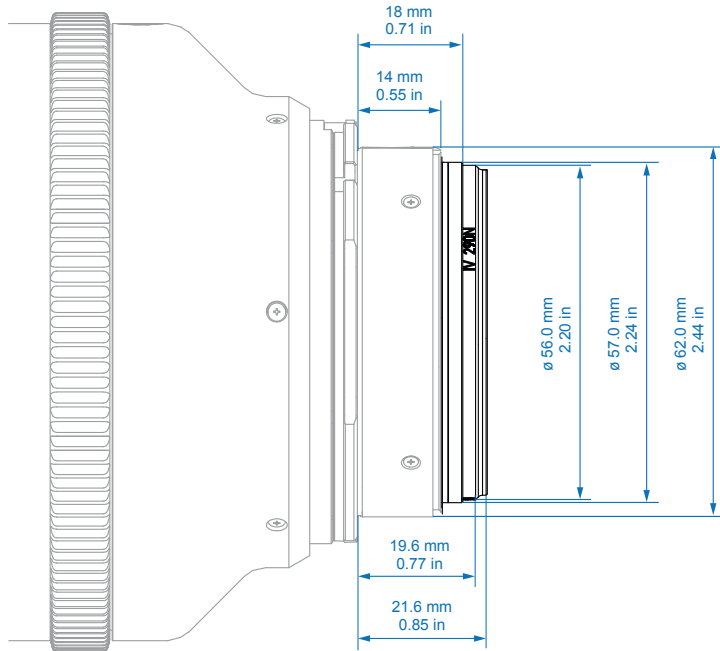

Left

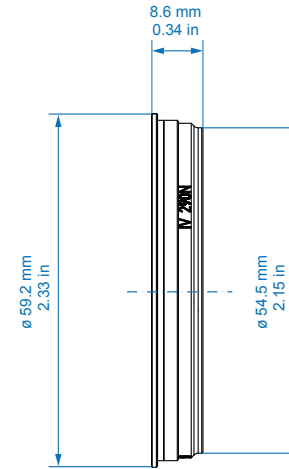

Front

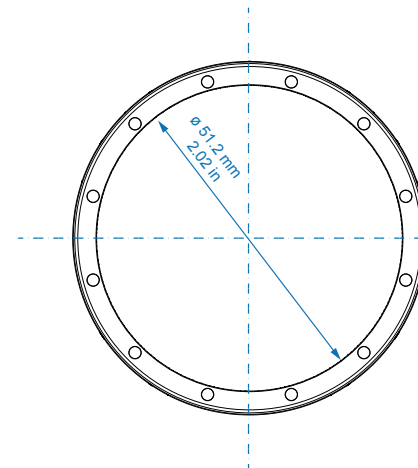

Back

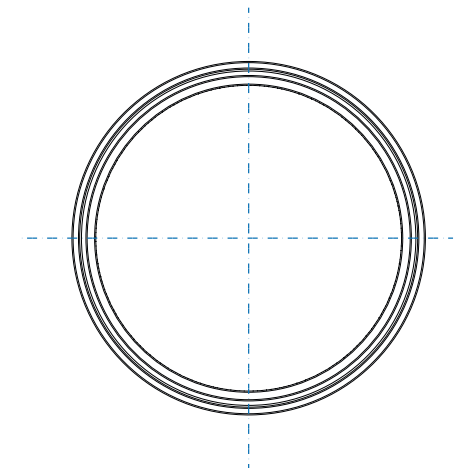

Dimensions apply to all Impression V Filters

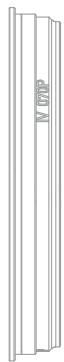

IV 070P

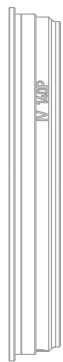

IV 140P

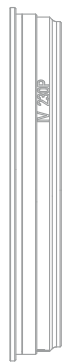

IV 230P



IV 330P



IV 050N



IV 100N



IV 200N



IV 290N