

Camera Accessories for ALEXA 35: Audio Extension Module AEM-1

USER MANUAL

April 18 2023 (1.1)



Disclaimer

Before using the products, be sure to read and understand all respective instructions.

The products are available for commercial customers only.

For product specification changes since this manual was published, refer to the latest publications of ARRI data sheets or data books, etc., for the most up-to-date specifications. Not all products and/or types are available in every country. Please check with an ARRI sales representative for availability and additional information.

ARRI assumes no responsibility for any errors that may appear in this document. The information is subject to change without notice.

While ARRI endeavors to enhance the quality, reliability and safety of their products, customers agree and acknowledge that the possibility of defects thereof cannot be eliminated entirely. To minimize risk of damage to property or injury (including death) to persons arising from defects in the products, customers must incorporate sufficient safety measures in their work with the system and have to heed the stated canonic use.

ARRI or its subsidiaries expressly exclude any liability, warranty, demand or other obligation for any claim, representation, or cause, or action, or whatsoever, express or implied, whether in contract or tort, including negligence, or incorporated in terms and conditions, whether by statute, law or otherwise. In no event shall ARRI or its subsidiaries be liable for or have a remedy for recovery of any special, direct, indirect, incidental, or consequential damages, including, but not limited to lost profits, lost savings, lost revenues or economic loss of any kind or for any claim by third party, downtime, good will, damage to or replacement of equipment or property, any cost or recovering of any material or goods associated with the assembly or use of our products, or any other damages or injury of the persons and so on or under any other legal theory.

Neither ARRI nor its subsidiaries assume any liability for infringement of patents, copyrights or other intellectual property rights of third parties by or arising from the use of ARRI products or any other liability arising from the use of such products. No license, express, implied or otherwise, is granted under any patents, copyrights or other intellectual property right of ARRI or others.

ARRI or its subsidiaries do not assume any responsibility for incurred losses due to improper handling or configuration of the camera or other system components, due to sensor contamination, occurrence of dead or defective pixels, defective signal connections or incompatibilities with third party recording devices.

In the case one or all of the foregoing clauses are not allowed by applicable law, the fullest extent permissible clauses by applicable law are validated.

Content

- 1 About the Products..... 6**
- 1.1 Identification..... 6
- 1.2 Environmental Conditions..... 8
- 1.3 Technical Data..... 9
- 1.4 Dimensional Drawings..... 11
- 1.5 Scope of Delivery and Warranty..... 12
- 1.6 Certification and Safety Standards..... 12

- 2 Safety Instructions.....14**
- 2.1 Safety Conventions and Product Labels..... 14
- 2.2 General Safety Instructions..... 15

- 3 Overview Audio Extension Module AEM-1..... 17**

- 4 Mounting the Accessories..... 18**

- 5 Operating..... 20**
- 5.1 Switch on Audio Extension Module AEM-1.....20
- 5.2 Home Screen Overview and Navigation..... 20
- 5.2.1 Home Screen Overview.....20
- 5.2.2 Home Screen Control Elements.....20
- 5.3 Menu Overview and Navigation..... 22
- 5.3.1 Menu Overview.....22
- 5.3.2 Menu Navigation.....22
- 5.4 Selecting an Input Source..... 23
- 5.5 Analog Input Settings..... 24
- 5.5.1 Gain Input..... 24
- 5.5.2 Limiter Threshold..... 25
- 5.6 Digital Input Settings.....25
- 5.7 Headphone Settings..... 25
- 5.8 Reference Tone Settings..... 26
- 5.9 Peak Meters.....26
- 5.10 AEM-1 OLED Brightness.....27
- 5.11 Software Update..... 27
- 5.12 Reset to default settings.....28
- 5.13 Power Input Control.....28
- 5.14 Error Messages and Debugging.....29

- 6 Cleaning and Repair.....30**
- 6.1 Cleaning Instructions..... 30
- 6.2 Repair.....30

7	Transportation and Storage.....	31
8	Disposal.....	32
9	ARRI Service Contacts.....	33

About this Document

This user manual is aimed at everyone involved in using the system and provides directions on how to operate it safely and as intended. To ensure safe and correct use, all users must read the user manual before using the accessories for the first time.

This user manual is an essential part of this product and must be easily accessible and in proximity to the equipment so that users can use it as a reference anytime.

Keep this user manual and all other operating and assembly instructions belonging to the system in a safe place for future reference and possible subsequent owners.

Document Revision History

Document ID: D45 10006708

Version	Release	Date	Description
1.0	K10950	04.07.2022	Initial Release
1.1	K11244	18.04.2023	Revised Update Procedure

1 About the Products

ATTENTION

All versions of the product are intended exclusively for professional use and may only be used by skilled personnel.

Every user should read and understand the operating instructions and the user manual. Use the product only for the purpose described in this document. Always follow the instructions and system requirements for all equipment involved.

The Audio Extension Module AEM-1 enables audio source selection for the ALEXA 35 and serves as a microphone amplifier. In camera playback mode, the audio from the camera is injected into the main audio channels.

In all other camera states, the audio source can be:

- Main MIC/LINE inputs
- AES input
- Reference tone generator

The Audio Extension Module AEM-1 is compatible with the ALEXA 35.

1.1 Identification

The product number and the serial number of the accessory are located on the product label, the serial number consists of the last 4 digits of the product number (here: 1234). The B-Mount Battery Adapter comes without a serial number.

B-Mount Battery Adapter (K2.0023751)

ARNOLD & RICHTER CINE TECHNIK GMBH & CO.
BETRIEBS KG, HERBERT-BAYER-STR. 10
D-80807 MUENCHEN
Made in Germany

B-Mount Battery Adapter
K2.0023751

CAN ICES3/NMB3(A)
This device complies with part 15 of the FCC Rules.
Operation is subject to the following two conditions:
(1) This device may not cause harmful interference, and
(2) this device must accept any interference received, including interference that may cause undesired operation.

UK
CA
CE
i
20.5-33.6V
max. 20A

Battery Adapter Back BAB-LF (K2.0034204)

ARNOLD & RICHTER CINE TECHNIK GMBH & CO.
BETRIEBS KG, HERBERT-BAYER-STR. 10
D-80807 MUENCHEN
Made in Germany

Battery Adapter Back BAB-LF
K2.0034204 - 1234

CAN ICES3/NMB3(A)
This device complies with part 15 of the FCC Rules.
Operation is subject to the following two conditions:
(1) This device may not cause harmful interference, and
(2) this device must accept any interference received, including interference that may cause undesired operation.

UK
CA
CE
i
20.5-33.6V
max. 20A

External Power Adapter EPA-1 (K2.034205)

ARNOLD & RICHTER CINE TECHNIK GMBH & CO.
BETRIEBS KG, HERBERT-BAYER-STR. 10
D-80807 MUENCHEN
Made in Germany

External Power Adapter EPA-1
K2.0034205 - 1234

CAN ICES3/NMB3(A)
This device complies with part 15 of the FCC Rules.
Operation is subject to the following two conditions:
(1) This device may not cause harmful interference, and
(2) this device must accept any interference received, including interference that may cause undesired operation.

UK
CA
CE
i
10.5-33.6V
max. 20A

Power Distribution Module PDM-1 (K2.0024101)



ARNOLD & RICHTER CINE TECHNIK GMBH & CO.
BETRIEBS KG, HERBERT-BAYER-STR. 10
D-80807 MUENCHEN
Made in Austria

Power Distribution Module PDM-1
K2.0024101 - 1234

CAN ICES3/NMB3(A)
This device complies with part 15 of the FCC Rules.
Operation is subject to the following two conditions:
(1) This device may not cause harmful interference, and
(2) this device must accept any interference received, including interference that may cause undesired operation.

UK
CA
CE
i
20.5-33.6V
max. 20A

**Audio Extension Module AEM-1
(K2.0023750)**

	<p>SONOSAX SAS S.A. CH. DE LA NAZ 38 CH-1052 LE MONT-SUR-LAUSANNE Made in Switzerland</p>	<p>UK CA CE</p>
<p>Audio Extension Module AEM-1 K2.0023750 - 1234</p>		
<p>CAN ICES3/NMB3(A) This device complies with part 15 of the FCC Rules. Operation is subject to the following two conditions: (1) This device may not cause harmful interference, and (2) this device must accept any interference received, including interference that may cause undesired operation.</p>		
		<p>20.5-33.6V max. 20A</p>

1.2 Environmental Conditions

The ALEXA 35 electronic accessories should only be used and stored under certain environmental conditions. Check the following conditions before commissioning and operation:

Electrical Requirements	Input voltage: 20.5 - 33.6 V DC
Operating Temperature	-20° C to +45° C / -4° F to +113° F
Storage Temperature	-30° C to +70° C / -22° F to +158° F
Humidity	0-95% RH from -20° C to +45° C / -4° F to +113° F, non-condensing

1.3 Technical Data

B-Mount Battery Adapter

Voltage Range	20.5 – 33.6 V (max. 20 A)
Measurements (HxWxL)	89.70 x 93.60 x 21.90 mm / 3,531 x 3,685 x 0,862"
Weight	95 g / 0,21 lbs

Battery Adapter Back BAB-LF

Voltage Range	20.5 – 33.6 V (max. 20 A)
Measurements (HxWxL)	132.50 x 102.60 x 19.52 mm / 5,217 x 4,039 x 0,769"
Weight	152 g / 0,34 lbs

Power Distribution Module PDM-1

Voltage Range	20.5 – 33.6 V
Measurements (HxWxL)	133.0 x 118.0 x 33.0 mm / 5,236 x 4,646 x 1,230"
Weight	358 g / 0,789 lbs

Power Outputs 4x 24 V 3-pin Fischer connectors supporting REC start/stop (max. 4.0 A)
 2x 12 V 2-pin Lemo connectors (max. 2.0 A)
 1x Twist D-Tap connector with a recessed positive pin (12 V, max. 2.0 A)

Connector Pin Outs Fischer DPB102A052-130

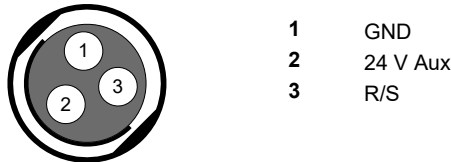

LEMO EEG.0B.302.CLN.A365

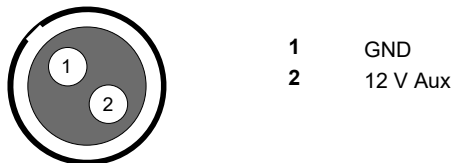

External Power Adapter EPA-1

Voltage Range	10.5 – 33.6 V (max. 20 A)
Measurements (HxWxL)	94.0 x 108.0 x 44.7 mm / 3,701 x 4,252 x 1,760"
Weight	346 g / 0,763 lbs

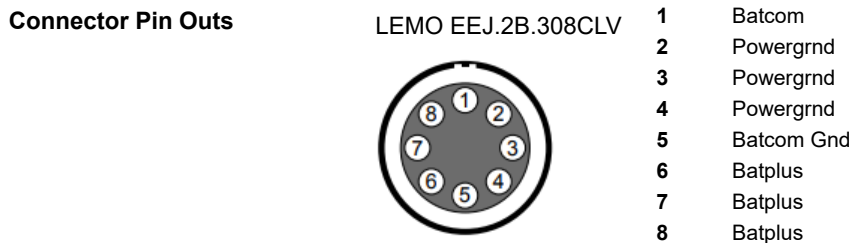

Audio Extension Module AEM-1

Measurements (HxWxL)	132.50 x 119.45 x 34.72 mm
Weight	504 g / 1,111 lbs
Frequency Response	20 Hz - 90 kHz
Operating Temperature	-20°C - +45°C
Power Outputs	1x 24 V 3-pin Fischer connector supporting start/stop (max. 4.0 A) 1x 12 V 2-pin Lemo connector (max. 2.0 A)
Maximum Input Level	+18 dBu (with Primary Gain 0 dB) -2 dBu (with Primary Gain +20 dB)
Analog Audio Inputs	2x balanced MIC/LINE inputs on TA3 connectors with 48 V phantom power (max. 10 mA) switchable on each channel, +20 dB pre-gain, analog first order low frequency cut filter, dual-ADC, phase reversal, adjustable second order digital low frequency cut filter, gain and limiter
Low Frequency Cut Filter	3rd order hybrid (1st order analog) adjustable Low Frequency Cut filter, 60 to 320 Hz, 20 Hz steps
Dynamic Range	135 dB (with Primary Gain 0 dB) 129 dB (with Primary Gain +20 dB)
Noise LIN 22-22 kHz	-133 dBFS (with Primary Gain 0 dB) -127 dBFS (with Primary Gain +20 dB)
Noise ASA A	-135 dBFS (with Primary Gain 0 dB) -129 dBFS (with Primary Gain +20 dB)
Equivalent Input Noise 22-22 kHz 150 Ω	-112 dBu (with Primary Gain 0 dB) -126 dBu (with Primary Gain +20 dB)
THD	< 0.001%
Digital Audio Input	1x AES input on TA3 connector with asynchronous sample rate converter (ASRC)
AES3 Input Sampling Rate	6 - 192 kHz
AES3 Output Sampling Rate	48 kHz
ASRC Dynamic Range	139 dB (A-weighted)
Headphone Output	1x stereo mini jack unbalanced output for headphones with full monitoring

1.4 Dimensional Drawings

All measurements given in Millimeters.

B-Mount Battery Adapter

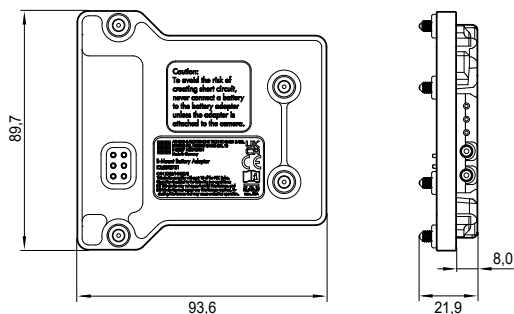

External Power Adapter EPA-1

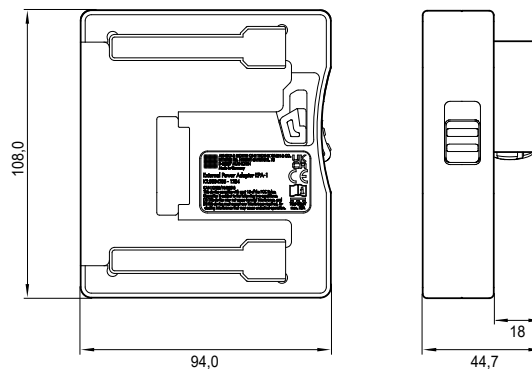

Battery Adapter Back BAB-LF

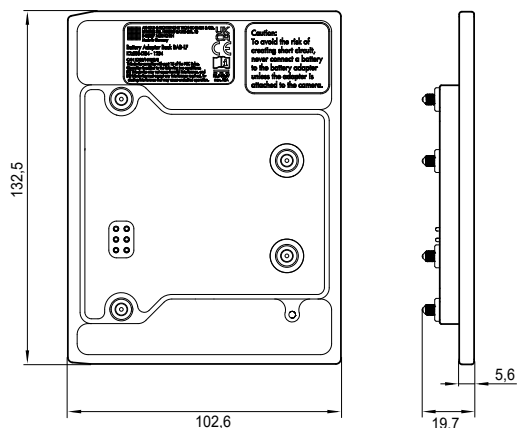

Power Distribution Module PDM-1

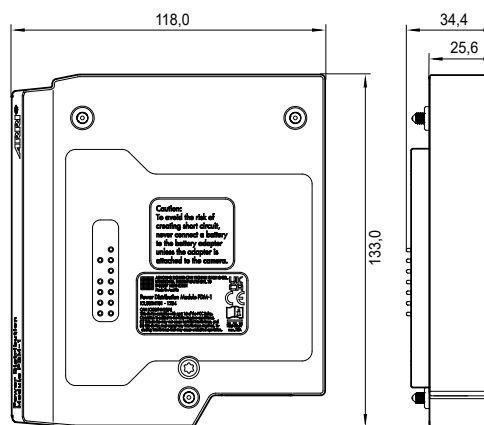

Audio Extension Module AEM-1

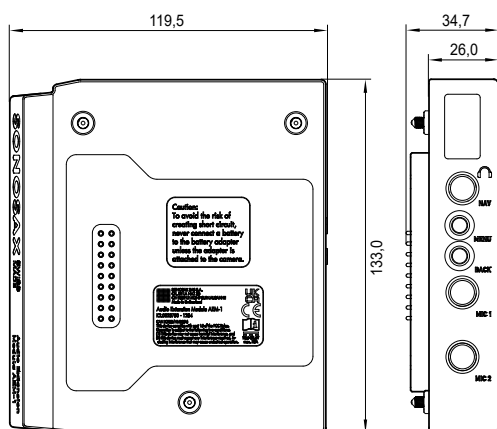

1.5 Scope of Delivery and Warranty

ATTENTION

The packaging consists of recyclable materials. For the sake of the environment, dispose of the packaging material at a suitable disposal site.

Always store, ship and dispose according to local regulations. ARRI is not liable for consequences from inadequate storage, shipment or disposal.

On delivery, please check if package and content are intact. Never accept a damaged delivery.

Warranty

For scope of warranty, please ask your local ARRI Service Partner. ARRI is not liable for consequences from inadequate shipment, improper use or third-party products.

1.6 Certification and Safety Standards

Approval Information

The Audio Extension Module AEM-1 is approved for use in countries where the CE or FCC declaration is accepted. That contains the European Union, Canada, Japan and the USA. The import and use in other countries may be subject to legal, official or regulatory requirements and regulations. It is the importer's or the user's responsibility, prior to importation or use, to inform themselves of the applicable legal, regulatory and administrative requirements and regulations and to ensure compliance with these requirements and regulations. This includes the applying for and obtaining of all necessary approvals or registrations.

As far as reasonable and legally possible, ARRI will support requests in relation to such applications by providing technical documents or declarations. As an importer or user, you confirm that you are familiar and comply with the legal, regulatory, and administrative requirements and regulations that apply in the countries to which you ship or use the products. You further confirm that you will arrange for any necessary registrations, enrollments, or authorizations that are required in such countries.

You release ARRI from all obligations resulting from any legislative, regulatory, or administrative requirements regarding import or use of the products, except in countries where ARRI has obtained a registration or certification. You agree to indemnify, defend, and hold ARRI harmless from any and all claims, damages, losses, liabilities, costs, and expenses (including reasonable fees of attorneys and other professionals) that may arise out of a demand on ARRI in connection with your obligations mentioned above.

EU Declaration of Conformity



Brand Name: SONOSAX SAS SA
Product Description: Audio Extension Module **AEM-1**

The product conforms to the specifications of the following European directives:

- Directive 2014/30/EU EU of the European Parliament and of the Council of 26 February 2014 on the harmonisation of the laws of the Member States relating to electromagnetic compatibility
- Directive 2014/35/EU of the European Parliament and of the Council of 26 February 2014 on the harmonisation of the laws of the Member States relating to the making available on the market of electrical equipment designed for use within certain voltage limits

Compliance with the requirements of the European directives has been verified by applying the following standards:

- EN 55032:2015
- EN 55035:2017
- IEC 62368-1:2018

UK Declaration of Conformity



Brand Name: SONOSAX SAS SA
Product Description: Audio Extension Module **AEM-1**

The designated products conform to the specifications of the following United Kingdom regulations:

- 1) The Electromagnetic Compatibility Regulations 2016 (SI 2016 No. 1091 as amended by SI 2019 No. 696)
- 2) The Electrical Equipment (Safety) Regulations 2016 (SI 2017 No. 1206 as amended by SI 2019 No. 696)
- 3) The Restriction of the Use of Certain Hazardous Substances in Electrical and Electronic Equipment Regulations 2012 (SI 2012 No. 3032 as amended by SI 2020 No. 1647 SI 2021 No. 422 and SI 2019 No. 492)

The compliance with the requirements of the United Kingdom regulations was proved by the application of the following standards:

- EN 55032:2015 + A11:2020
- EN 55035:2017 + A11:2020
- IEC 62368-1:2014/AC:2015
- EN IEC 63000:2018

The manufacturer bears sole responsibility for issuing this declaration of conformity.

FCC Class A Statement

This equipment has been tested and found to comply with the limits for a Class A digital device, pursuant to Part 15 of the FCC Rules. These limits are designed to provide reasonable protection against harmful interference when the equipment is operated in a commercial environment. This equipment generates, uses, and can radiate radio frequency energy and, if not installed and used in accordance with the instruction manual, may cause harmful interference to radio communications. Operation of this equipment in a residential area is likely to cause harmful interference in which case the user will be required to correct the interference at his own expense.

Changes or modifications to the product not expressly approved by the party responsible for compliance could void the user's authority to operate the equipment.

Industry Canada Statement

CAN ICES-003(A)/NMB-003(A)

2 Safety Instructions

This safety information is in addition to the product specific operating instructions in general and must be strictly observed for safety reasons. Read and understand all safety and operating instructions before you operate or install the system. Retain all safety and operating instructions for future reference. Always follow the instructions in this and all documents supplied with the device to avoid injury to yourself or others and damage to the system or other objects.

Assembly and operation should only be carried out by trained staff familiar with the system. Only use the tools, materials and procedures recommended in this document. For the correct use of other equipment, see the manufacturer's instructions.

2.1 Safety Conventions and Product Labels

Structure of Safety and Warning Messages

These instructions use safety instructions, warning symbols and signal words to draw your attention to different levels of risk:

⚠ WARNING
<p>WARNING indicates a potentially hazardous situation which, if not avoided, may result in death or serious injury.</p> <ul style="list-style-type: none">▶ Always follow the recommended measures to avoid this hazardous situation.
⚠ CAUTION
<p>CAUTION indicates a potentially hazardous situation which, if not avoided, may result in minor or moderate injury.</p> <ul style="list-style-type: none">▶ Always follow the recommended measures to avoid this hazardous situation.
ADVICE
<p>ADVICE signifies a potentially hazardous situation which can result in damage to property.</p> <ul style="list-style-type: none">▶ Always follow the recommended measures to avoid this hazardous situation.
ATTENTION
<p>Not relevant to safety, ATTENTION provides additional information to clarify or simplify a procedure.</p>

Warning Symbols and Product Labels



General warning sign



Warning of electrical voltage



Warning of hot surfaces



Warning of hand injuries



Warning of the risk of crushing



Warning of obstacles on the ground



Please read all instructions carefully before using the product for the first time.



Direct Current symbol found on electronics requiring or producing DC power

2.2 General Safety Instructions

⚠ WARNING



Powering Accessories without Camera Connection

Risk of electric shock and fire hazard caused by short circuit.

- ▶ Do not power the accessories if not attached to the camera.
- ▶ Remove all power sources before you mount and remove accessories.

⚠ WARNING



Operation of the Camera System in Case of Obvious Damage

Risk of electric shock and fire hazard caused by short circuit.

- ▶ Do not use the system if electrical lines or housing are visibly damaged.
- ▶ Operate the system using only the type of power source indicated in the manual.
- ▶ Unplug the power cable by gripping the power plug, not the cable.
- ▶ Do not operate the system in areas with humidity above operating levels or expose it to water or moisture.
- ▶ Do not get the system wet.
- ▶ Do not lay cables over sharp edges (e.g. sheet metal, profile or other cut edges). Damaged cables can cause electric shock, short circuit or fire.
- ▶ Do not remove or deactivate any safety measures from the system (incl. warning stickers or paint marked screws).
- ▶ Repairs may only be carried out by authorized ARRI service partners.

⚠ CAUTION

Using the Camera or Camera Accessories in a Humid Environment and with Condensation



When moving the camera and the camera accessories from a cool to a warm location or when the camera is used in a damp environment, condensation may form inside the camera, on the sensor, and on internal or external electrical connections. Operating the camera while condensation is present bears risk of electric shock and/or fire caused by a short circuit.

- ▶ Never operate the camera and camera accessories when condensation occurs.
- ▶ After moving the camera and camera accessories from a cool to a warm environment, wait for some time for the system to warm up.
- ▶ To reduce the risk of condensation, find a warmer storage location.

⚠ CAUTION**Hot Surfaces on Camera Body and Camera Accessories**

During extended operation, high data rates and/or operation at high ambient temperatures, the camera's surface and the area around the fan outlet can get hot. Direct sunlight can result in camera housing temperatures above 60° C (140° F).

- ▶ Never cover, obstruct or block the fan in- or outlets while the camera is powered.
- ▶ Do not place the camera system near any heat sources during operation.
- ▶ At ambient temperatures above 25° C (77° F), protect the camera and camera accessories from direct sunlight.

⚠ CAUTION**Connected Cable on the Floor**

Risk of injury caused by tripping, falling or slipping over connected cables.

- ▶ Always properly secure cables connected to the camera and camera accessories.
- ▶ Install cables in a way that they cannot be tripped over.
- ▶ If necessary, use a cable duct or secure the cables with adhesive tape.
- ▶ Disconnect the cables from the camera and camera accessories before moving.

3 Overview Audio Extension Module AEM-1

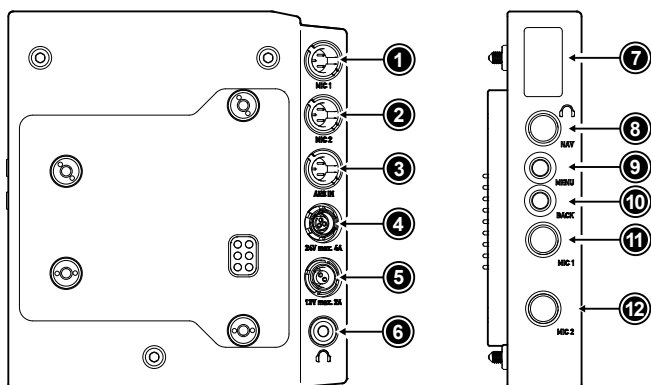

- 1 MIC 1 Input
- 2 MIC 2 Input
- 3 AES Input
- 4 24 V Output
- 5 12 V Output
- 6 Headphones Output
- 7 User Display
- 8 Rotary Encoder for Phones Level and Menu Navigation
- 9 Menu Button
- 10 BACK Button
- 11 Rotary Encoder for MIC 1 Gain
- 12 Rotary Encoder for MIC 2 Gain

A USB port is used for firmware update. It acts as a USB host which will read a file from a USB stick connected to it.



4 Mounting the Accessories

⚠ WARNING



Falling Camera Accessories

If the system is inadequately built up or assembled, it can fall down and cause serious injuries and damage to the system or property.

- ▶ Installation and operation may only be carried out by trained personnel who are familiar with the system. Observe accident prevention regulations.
- ▶ Do not place the system on an unstable trolley or hand truck, stand, tripod, bracket, table or any other unstable support device.
- ▶ Always place the camera on dedicated support devices.
- ▶ Secure the system and its accessories against falling and tipping over. Observe the general and local safety regulations.
- ▶ When using the system on camera cranes, a suitable safety rope must be used.
- ▶ Use only accessories approved by ARRI. The use of accessories not approved by ARRI is at your own risk. Please observe all relevant safety guidelines.

⚠ CAUTION



Improper Mounting of Lenses and Accessories

Mounting the camera on tripods or other support equipment and attachment of accessories like e.g. lenses, electronic and mechanical accessories poses a crushing hazard for fingers and/or hands.

- ▶ Before mounting ARRI accessories or recommended third-party accessories (such as lenses, mechanical accessories, electronic accessories), read the operating instructions provided by the manufacturer.
- ▶ Always use the tools specified by the manufacturer for mounting.

ATTENTION

The Audio Extension Module AEM-1 is compatible with the ALEXA 35.

Please note that either the Audio Extension Module AEM-1 or the Power Distribution Module PDM-1 can be mounted on the camera.

Preparation:

- ▶ Switch off the camera and unplug any power supply.
- ▶ Arrange the ALEXA 35 on a table with its back turned towards you.
- ▶ Put the unpacked accessory next to the camera.
- ▶ Prepare a 3.0 mm Allen/hex key.

Preparation:

- Switch off the camera and unplug any power supply.
- Arrange the ALEXA 35 on a table with its back turned towards you.
- Put the unpacked Audio Extension Module AEM-1 next to the camera.
- Prepare a 3.0mm Allen/hex key.

How to mount Audio Extension Module AEM-1:

The Audio Extension Module AEM-1 attaches to the back of the camera with three captive M4 screws.

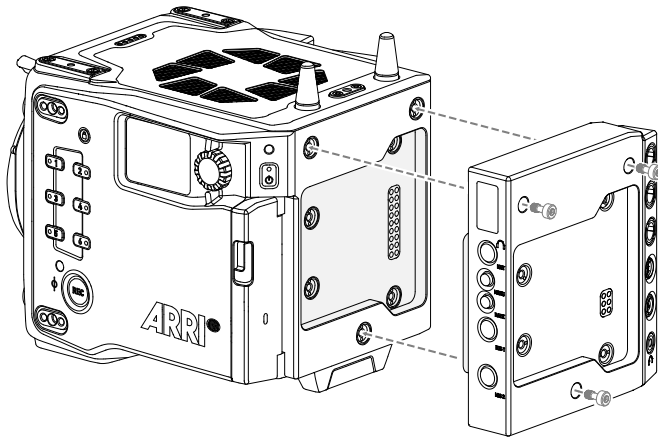

1. Gently place the Audio Extension Module AEM-1 counterpart in the recessed area at the back of the camera.
2. Tighten the three captive M4 screws crosswise with a 3mm Allen key to attach the Audio Extension Module AEM-1 to the camera.
3. Check with your hands if the Audio Extension Module AEM-1 is firmly attached to the camera.

→The Audio Extension Module AEM-1 is ready for use.

5 Operating

ATTENTION

The AEM-1 automatically saves all your selected settings in the menu. These settings are retained even after the power is turned off.

To ensure that no settings can be lost, you should wait for 10 seconds after you have adjusted a setting, before switching off the AEM-1.

5.1 Switch on Audio Extension Module AEM-1

The Audio Extension Module AEM-1 is powered from 12V or 24V camera and will boot up as soon as a power supply is applied.

After the boot-process, the home screen appears in the user display. Depending on the selected input source, the home screen looks slightly different:

Analog Input

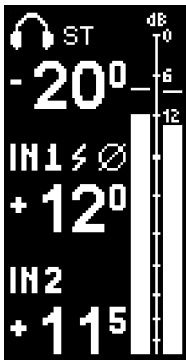

Digital Input

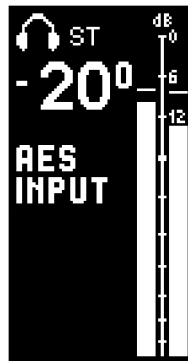

Camera Source



5.2 Home Screen Overview and Navigation

5.2.1 Home Screen Overview

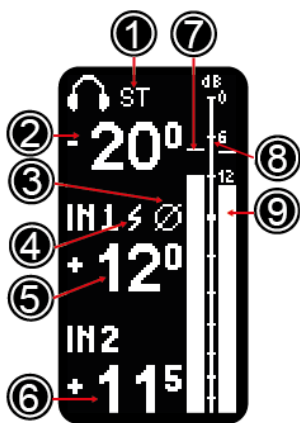

- 1 Monitoring Routing
- 2 Head Phones level
- 3 Phase reversal
- 4 Phantom power
- 5 Input Gain 1
- 6 Input Gain 2
- 7 Peak Hold
- 8 Reference Level
- 9 Peak Meters

5.2.2 Home Screen Control Elements

During the Home screen, the control elements on the Audio Extension Module AEM-1 are used as follows:

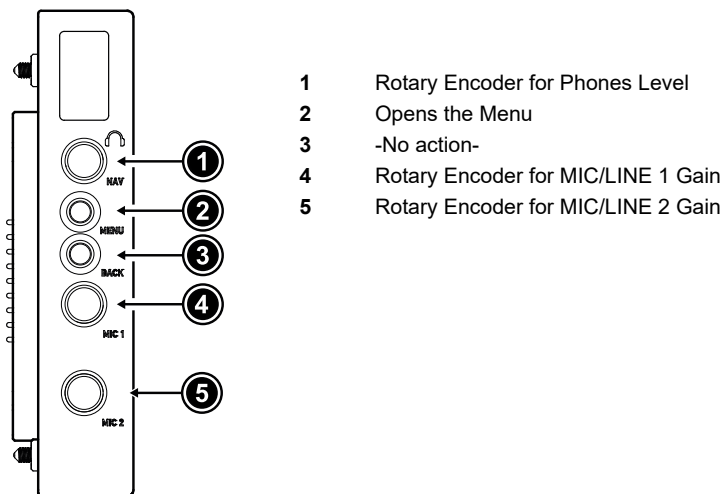

The three rotary encoder can be moved in and out by pressing them.

5.3 Menu Overview and Navigation

5.3.1 Menu Overview

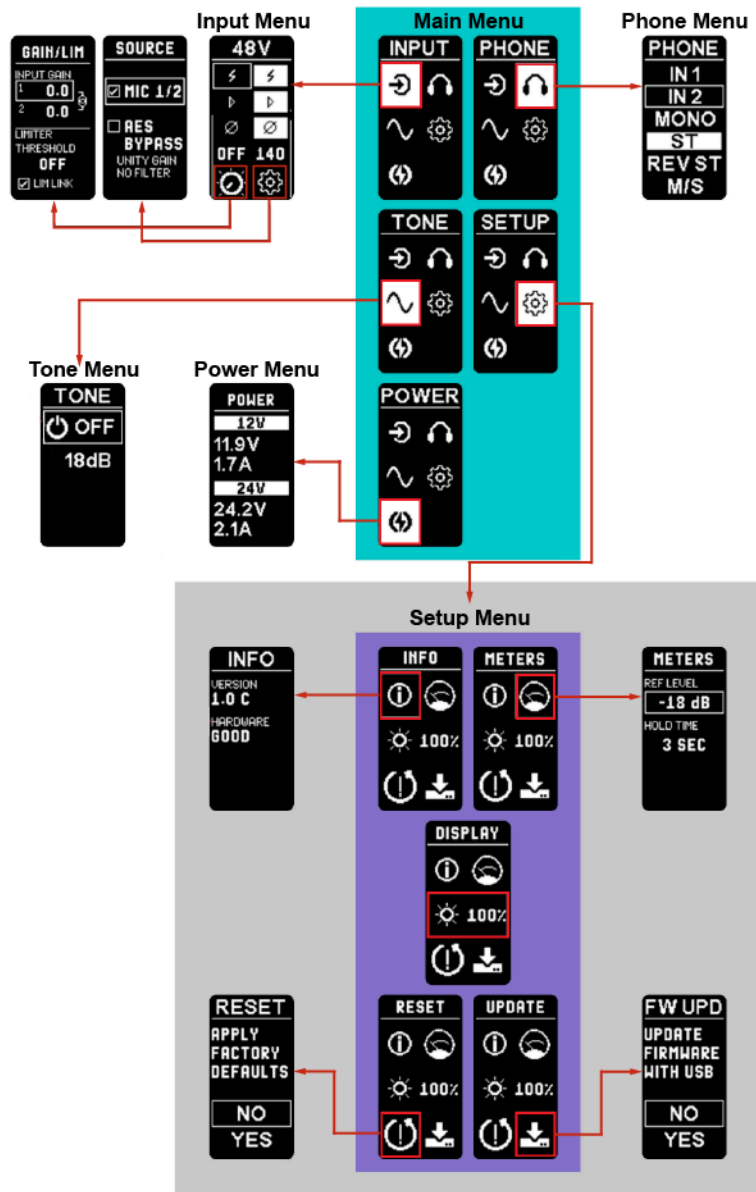

5.3.2 Menu Navigation

Press the **MENU** button on the Audio Extension Module AEM-1 to open the menu.

The following buttons are used within the menu:

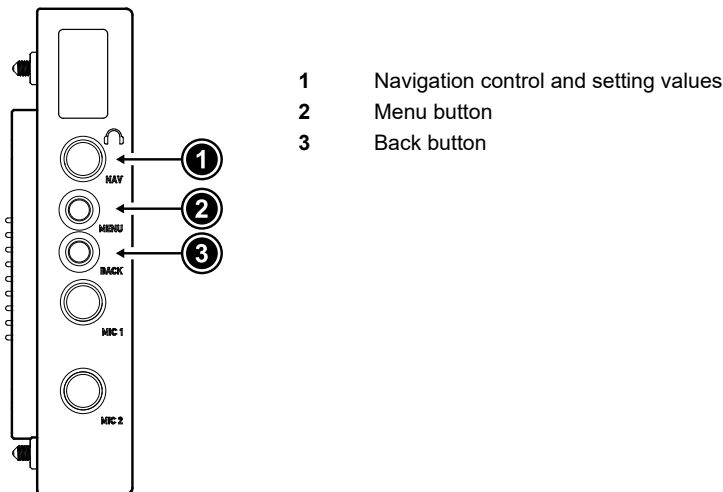

The **Navigation control** allows to switch between different menu items and function controls. With the navigation control you can also adjust values.

To select a menu item or confirm changes, use the **Menu** button.

To cancel a setting procedure or to return to a previous menu, press the **Back** button.

A long press on the **Back** button returns to the home screen.

5.4 Selecting an Input Source

ATTENTION

If you have selected the digital input or camera source, all the settings for the analog inputs in the menu are hidden.

You have three different possibilities for the AEM-1 input source:

- Analog Input** 2 analog inputs independently configurable
- Digital Input** 1 input for external devices
- Camera Source** When you select the Camera Source, the AEM-1 connects directly to the camera. Thereby you can listen to recorded audio on the camera.

How to select an input source:

1. Open the menu via **Menu** button.
2. Go to *INPUT > SOURCE* .

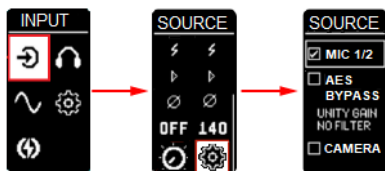

3. Select an input source.
 → The selected input source is displayed on the Home screen.

5.5 Analog Input Settings

ATTENTION

As long as another source than analog is selected, the analog settings are all hidden in the input setting menu.

All analog input settings are found in the input settings menu.

► Select *MENU > INPUT*.

This menu configures both the analog MIC 1/2, the AES input and camera source. When using MIC 1/2 inputs, the input menu is built as following:

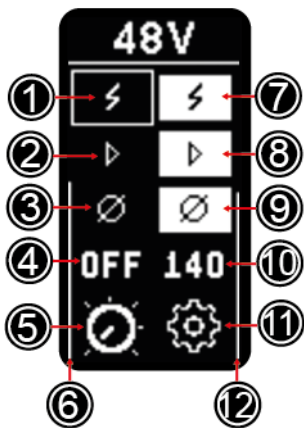

- 1 MIC 1 48V phantom power
- 2 MIC 1 +20dB pre-gain
- 3 MIC 1 phase reversal
- 4 MIC1 low frequency cut filter
- 5 Gain Settings
- 6 MIC1 meter
- 7 MIC2 48V phantom power
- 8 MIC2 +20dB pre-gain
- 9 MIC2 phase reversal
- 10 MIC2 low frequency cut filter
- 11 Inputs Settings (Source Select)
- 12 MIC2 meter

All icons on the left side concerns the MIC 1 and on the right side MIC 2, except the last two buttons. The button (5) on the left side opens the Gain settings for MIC 1 and 2. The button (11) on the right allows to choose the input source.

5.5.1 Gain Input

ATTENTION

If you set the connected MIC 1/2 input gains with different values, pay attention to the limits. When an input gain reaches the limit, it will remain at that value, but the other value will continue to change up to the limit.

The gain input settings are in the menu item **GAIN/LIM**.

► Select *MENU > INPUT > GAIN/LIM*.

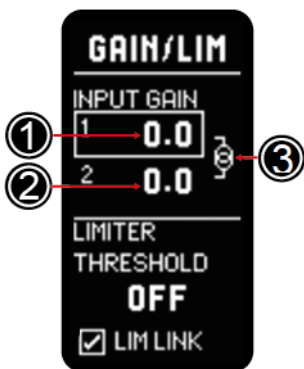

- 1 MIC 1 input gain
- 2 MIC 2 input gain
- 3 MIC 1/2 gain link

You can set the gain value for MIC 1 and MIC 2 independently or together. To change values together for both MIC inputs, activate the MIC 1/2 gain link.

The connection also works with different values for MIC 1 and MIC 2. The limits are between -24dB and 72dB.

5.5.2 Limiter Threshold

In order to prevent an overload of the analog input devices, a threshold value can be defined. It is possible to set values between 0 and - 30dBFS. The limiter can be disabled by setting the threshold to zero.

- ▶ Select *MENU > INPUT > GAIN/LIM.*

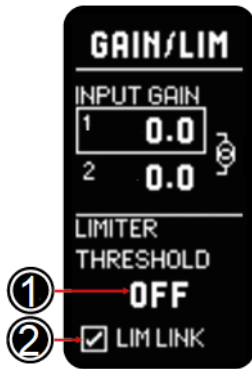

- 1 Threshold
- 2 LIM Link on/off

If you activate the LIM link function, both MIC inputs will be reduced, even if only one of them is clipping. If the LIM link function is deactivated, only the MIC input that is clipping is reduced.

5.6 Digital Input Settings

When AES input is selected, the Inputs Settings (=> Source Select) icon is the only one available in the input menu.

- ▶ Select *MENU > INPUT.*

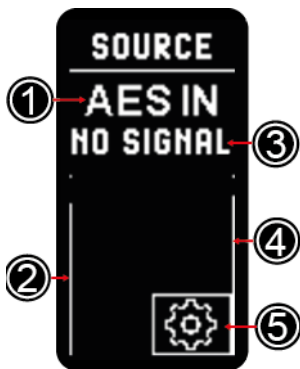

- 1 AES input in use
- 2 AES1 meter
- 3 Input sampling frequency (when locked)
- 4 AES2 meter
- 5 Inputs Settings (Source select)

5.7 Headphone Settings

The level of the head phone can be adjusted directly in the home screen via the Rotary Encoder for Phones Level see section ["Overview Audio Extension Module AEM-1"](#). You can adjust the level between -60dB and +20dB.

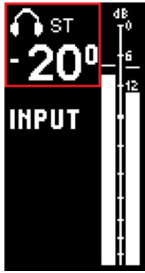

More settings can be adjusted in the menu item **PHONE**:

- ▶ Select *MENU > PHONE* .

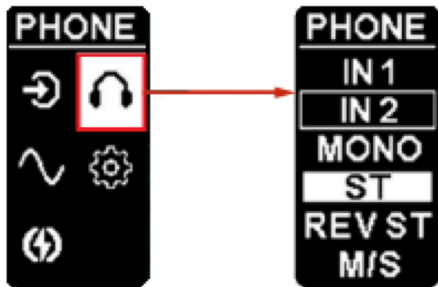

The *PHONE* menu allows the user to select how the two channels will be heard.

The following routing pattern are available:

- IN1: input 1 in mono to both ears
- IN2: input 2 in mono to both ears
- MONO: both inputs summed as mono to both ears
- ST: IN1 to left, IN2 to right (stereo)
- REV ST: IN2 to left, IN1 to right (reversed stereo)
- M/S decoding: M+S (IN1+IN2) to left channel, M-S (IN1-IN2) to right channel

5.8 Reference Tone Settings

Use the reference tone to further verify connections and to adjust the volume level of all output devices.

All reference tone settings can be adjusted in the **Tone** menu.

The reference tone generates a 1kHz sine wave with adjustable level. When enabled, it overrides the input channels. The level can be adjusted from -30 to 0dB. Default value is -18dB.



5.9 Peak Meters

The peak meters are on the right side of the home screen display.

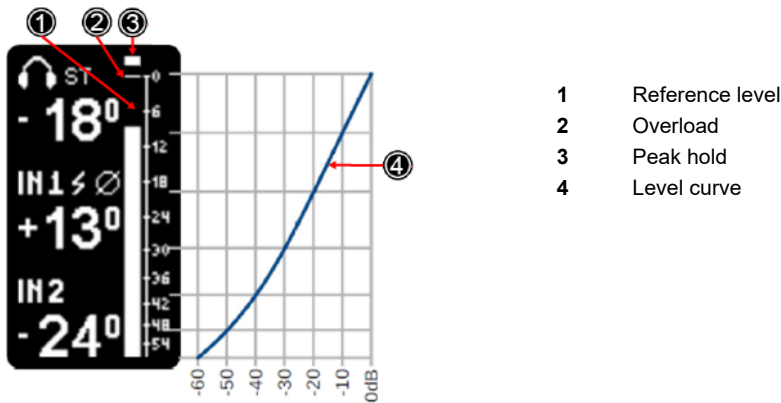

- 1 Reference level
- 2 Overload
- 3 Peak hold
- 4 Level curve

The peak meters system offers the following features:

- Dual modulometer with a range of 60dB in a level compression curve
- Overload indicators
- User adjustable reference level indicators
- User adjustable peak hold indicators

The reference level and peak hold indicators can be adjusted in the menu item **METERS**.

Adjusting the Reference Level

- ▶ Select *MENU > SETUP > METERS*.

The reference level displays a reference mark on the peak meters to help users adjusting the modulation level (the gain) up to that defined reference level.

The range is -30 to 0dB, the default is -18dB. When the reference level is set to 0dB, the reference mark doesn't appear.

Adjusting the Peak Hold Indicator

- ▶ Select *MENU > SETUP > METERS*.

The peak hold indicators are displayed in the peak meters as a horizontal bar. It indicates the highest peak measured value for a defined time.

The range is 0 to 30 seconds. When the peak hold indicators are set to 0, the peak hold indicators never appear. Factory default is 3 seconds.

5.10 AEM-1 OLED Brightness

The OLED brightness can be adjusted from 0 to 100%. When set to 0%, the display turns off after 4 seconds of user's inactivity. As soon as an action is detected, the display lights up again.

- ▶ Got to *MENU > SETUP > DISPLAY*

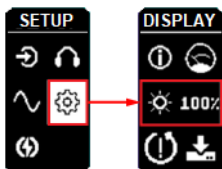

5.11 Software Update

The currently installed version is displayed in the INFO menu.

- ▶ Go to *MENU > SETUP > INFO* to view the installed version.

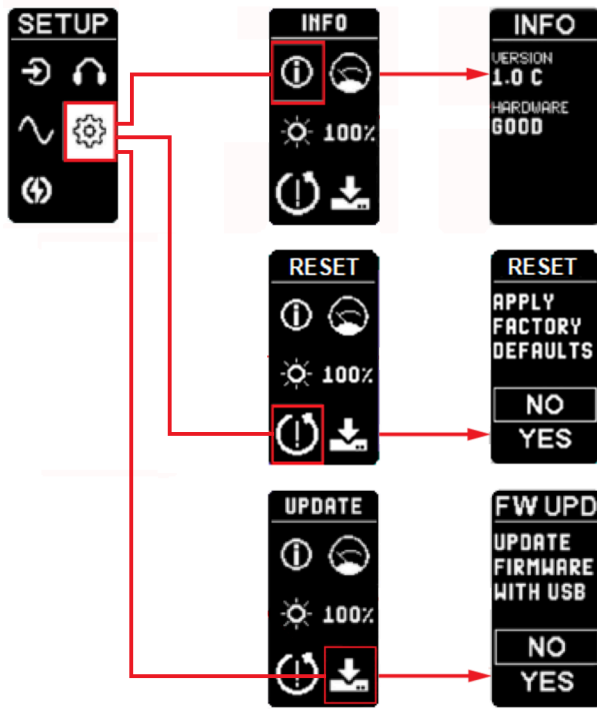

How to install the new version on the AEM-1 module:

1. Download the AEM-1 software from the Downloads section of the ALEXA 35 website.
2. Copy the file PAM.HEX on an USB memory stick formatted as FAT16 or FAT32 (no exFAT).
3. Got to *MENU > SETUP > RESET* to reset the AEM-1.
4. Go to *MENU > SETUP > UPDATE* and select YES to start the update.
5. Connect the memory stick with the AEM-1 module.
6. After the update is completed, remove the USB memory stick and restart the camera.

5.12 Reset to default settings

► Got to *MENU > SETUP > RESET*.

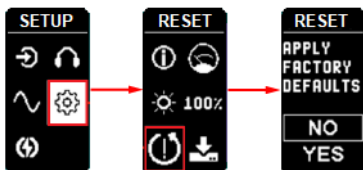

5.13 Power Input Control

To detect a possible overload at the 12V and 24V power input, there is a power input control indicator in the AEM-1 menu.

► Select *MENU > POWER*.

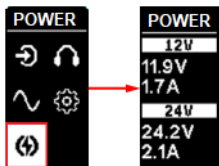

For each power input are displayed the current volt and amper values.

5.14 Error Messages and Debugging

When an error is detected, a message is posted in the home screen. It contains an error code, which is a decimal integer number. The same number can then be read from the SETUP/SYSTEM INFO menu.



The error code is a bitfield where:

Bit	Description
0	SigmaDSP failure
1	AK4104 digital transmitter failure
2	Missing dual-ADC calibration values

Debugging

The first thing to do if an error message occurs is to restart the system. If the error message persists, proceed as follows:

Possible reason:	Resolve error:
Hardware problem	<ol style="list-style-type: none"> 1 Switch off the camera, the Audio Extension Module AEM-1 and all other connected devices. 2 Check if the ARRI Audio Extension Module AEM-1 is correctly attached to the camera. 3 Check if all connected devices have been connected properly. 4 Restart the Audio Extension Module AEM-1.
Software problem	<p>Make sure that the latest software version is installed on the Audio Extension Module AEM-1.</p> <p>Go to <i>MENU > SETUP > INFO</i>.</p>

If the error message continues to appear on the ARRI Audio Expansion Module AME-1 display, contact ["ARRI Service"](#) .

6 Cleaning and Repair

6.1 Cleaning Instructions

ADVICE	
	Improper Cleaning Procedure Risk of damage of surfaces.
<ul style="list-style-type: none">▶ Only use the cleaning agents specified in this chapter.▶ Do not use any strong or aggressive cleaning detergents like Methanol, Acetone, Benzine or acids. These chemicals may dissolve the paint on the accessories and damage highly polished surfaces.▶ Do not moisten connectors when cleaning.▶ Compressed air should not be used on the electronic accessories.	

Recommended Cleaning Agents

- Water
- Glass Cleaner
- Isopropyl Alcohol

Cleaning Information

Before cleaning, remove the camera accessories from the camera and disconnect all cables.

Clean the accessories with a soft, lint free cleaning cloth and some water or glass cleaner.

Only when really necessary, e.g. to remove residues of camera tape, isopropyl alcohol should be used.

6.2 Repair

⚠ WARNING	
	Repairs carried out by Untrained Personnel Risk of electric shock and fire caused by short circuit.
<ul style="list-style-type: none">▶ Do not try to repair the device yourself. Repairs may only be carried out by authorized ARRI service partners.	

For repairs and maintenance work on the camera system, please contact ["ARRI Service"](#).

7 Transportation and Storage

ADVICE



Improper Packing and Transportation

Risk of damage to the accessories.

- ▶ Unplug all cables during transport.
- ▶ Only transport and storage the accessories in suitable cases.
- ▶ Follow the specified environmental conditions. Do not store the accessories in places where they may be subject to temperature extremes, direct sunlight, high humidity, severe vibration or strong magnetic fields.

If you have any questions regarding the transport or storage of ARRI products, please contact "[ARRI Service](#)".

8 Disposal

ATTENTION

The product can be returned to the manufacturer.



This product falls within the scope of Directive 2012/19 / EU OF THE EUROPEAN PARLIAMENT AND OF THE COUNCIL of June 4, 2012 on waste electrical and electronic equipment (WEEE II).

Accordingly, this product must not be disposed of with household waste. There are the respective country specific disposal rules that must be observed.

9 ARRI Service Contacts

Please see the current list of service partners at [Service contacts](#)



Arnold & Richter Cine Technik GmbH & Co. Betriebs KG
Herbert-Bayer-Str. 10
80807 Munich
Germany
+49 89 3809 2121
Business hours:
Mo. - Fr. 09:00 am - 05:00 pm (CET)
service@arri.de

ARRI Inc. / West Coast
3700 Vanowen Street
CA 91505 Burbank
USA
+1 818 841 7070
Business hours:
Mo. - Fr. 09:00 am - 05:00 pm (PT)
service@arri.com

ARRI Canada Limited
1200 Aerowood Drive, Unit 29
ON L4W 2S7 Mississauga
Canada
+1 416 255 3335
Business hours:
Mo. - Fr. 08:30 am - 05:00 pm (EDT)
service@arri.com

ARRI Asia Pte. Ltd.
164 Kallang Way, #03-01
349248 Singapore
Singapore
+65 6230 9488
Business hours:
Mo. - Fr. 9:00 am - 06:00 pm (CST)
service@arri.asia

ARRI CT Limited / London
2 Highbridge, Oxford Road
UB8 1LX Uxbridge
United Kingdom
+44 1895 457 000
Business hours:
Mo. - Thu. 09:00 - 17:30
Fr. 09:00 am - 05:00 pm (GMT)
service@arri-ct.com

ARRI Inc. / East Coast
617 Route 303
NY 10913 Blauvelt
USA
+1 845 353 1400
Business hours:
Mo. - Fr. 08:00 am - 05:30 pm (EST)
service@arri.com

ARRI Australia Pty Ltd
Suite 2, 12B Julius Ave
NSW 2113 North Ryde
Australia
+61 2 9855 4305
Business hours:
Mo. - Fr. 08:00 am - 05:00 pm (AEST)
service@arri.com.au

ARRI China (Beijing) Co. Ltd.
Chaowai SOHO Tower C, 6/F, 0628/0656
Chaowai Dajie Yi 6
Beijing
China
+86 10 5900 9680
Business hours:
Mo. - Fr. 09:00 am - 06:00 pm (CST)
service@arri.cn

ARRI Hong Kong Limited

41/F One Kowloon, 1 Wang
Yuen Street Kowloon Bay
Hong Kong
China
+852 2537 4266
Business hours:
Mo. - Fr. 09:00 am - 06:00 pm (CST)
service@arri.asia

ARRI Japan Kabushiki Kaisha

Service
Haneda Innovation City Zone K210, 1-1-4
Hanedakuko, Ota-Ku
144-0011 Tokyo
Japan
+81 3 6635 3750
Business hours:
Mo. - Fr. 10:00 am - 06:00 pm (JST)
info@arri.jp

CINEOM Broadcast DMCC.

Unit No. 2109, Jumeirah Bay Tower X2 Cluster X
Jumeirah Lakes Towers
P.O Box 414659
Dubai, UAE
+971 (0) 45570477
Business hours:
Sa. - Th. 10:00 am- 06:00 pm
arriservice.me@cineom.com

LINKA İthalat İhracat ve Dış Tic.

Distributor
Halide Edip Adivar Mah. Darülaceze Cad.
No:3 Akın Plaza Kat:5 95-96
34381 Şişli, İstanbul
Turkey
+90 2123584520
Business hours:
Mo. - Fr. 09:00 am - 06:00 pm (EET)
service@linkgroup.com.tr

ARRI Korea Limited

Kolon Digital Tower 1(#1505-06), 25
Seongsuil-ro 4 gil, Seongdong-gu
04781 Seoul
Korea
+82 (0)70 4419 6401
Business hours:
Mo. - Fr. 9:00 am - 06:00 pm (KST)
service@arri.kr

ARRI Brasil Ltda

Avenida Ibirapuera 2907 – Cj. 421, Indianópolis
04029-200 São Paulo
Brazil
+55 1150419450
Business hours:
Mo. - Fr. 09:00 am - 05:30 pm (BRT)
arribrasil@arri.com

CINEOM Broadcast India Pvt. Ltd.

C-4, Goldline Business Centre
Link Rd. Malad West
400 064 Mumbai
India
+91 (0)22 42 10 9000
Business hours:
Mo. - Sat. 10:00 am - 06:00 pm (IST)
arriupportindia@cineom.com